

INSTALLATION INSTRUCTIONS FOR MORTEX AIR CONDITIONING & HEAT PUMP INDOOR COILS

For Installation only in HUD manufactured homes per Construction Safety 24 CFR part 3280

INTRODUCTION

Please note that HUD Manufactured Home Construction and Safety Standard Section 3280.714, paragraph (a) and subparagraph (4) and (5) clearly specifies when a cooling or heat pump coil and air conditioner blower are installed with a furnace or heating appliance they shall be tested and listed in combination for heating and safety performance by a nationally recognized testing agency. Additionally, the cooling or heat pump systems to be installed in Manufactured Housing shall be certified, listed and rated based on U.S. Department of Energy test procedures which are listed by AHRI and shall be tested and listed in combination for heating and safety performance by a nationally recognized testing agency.

Mortex coils are designed specifically for use with various models of manufactured housing gas or electric furnaces in both down-flow and up-flow applications. A different drain pan will be required on upflow oil furnaces.

These instructions are intended to assist qualified individuals trained and experienced in the proper installation of heating and air conditioning equipment. Some state codes require installation and service personnel to be licensed. Refer to authorities having jurisdiction for additional guidance. The Clean Air Act of 1990 requires technician certification for handling refrigerant.

NOTE: Efficiency and capacity ratings are listed in the AHRI Unitary Directory (<https://ahridirectory.org>) under the indoor unit brand name Mortex for coil models matched with OEM outdoor condensing units or heat pump units. Air conditioning coils matches are listed under the Product Type of Residential/Air Conditioners and Air Conditioning Coils/AHRI Rating Conditions. Heat pump coil matches are listed under the Product Type of Residential/Heat Pumps/AHRI Rating Conditions. Incorrectly matched systems may not work properly and may void the manufacturers' warranties.

NOTE: Below is a partial listing of coils. Contact Mortex Products, Inc. with any questions.

Current Production Models (partial Listing)											
Coil Model Number	Dimensions			Coil Weight (lbs.)	Pallet qty.	Coil Model Number	Dimensions			Coil Weight (lbs.)	Pallet qty.
	Width	Depth	Height				Width	Depth	Height		
96-8Z4(*)-0P	18	19 5/8	18	32	16	96-893(*)-0P	18	19 5/8	16 1/2	36	20
98-8Z7(*)-0P	18	19 5/8	24	35	12	96-8W4(*)-0P	18	19 5/8	18 1/2	38	16
96-8G2(*)-0P	18	19 5/8	14	30	20	96-884(*)-0P	18	19 5/8	18 1/2	38	16
96-8G3(*)-0P	18	19 5/8	16	31	20	97-9W4(*)-0P	18	20 1/2	18 1/2	38	16
96-853(*)-0P	18	19 5/8	16	31	20	97-8W5(*)-0P	18	19 5/8	20 1/2	45	16
96-8G4(*)-0P	18	19 5/8	18	33	16	97-885(*)-0P	18	19 5/8	20 1/2	45	16
96-854(*)-0P	18	19 5/8	18	33	16	97-985(*)-0P	18	20 1/2	20 1/2	45	16
96-844(*)-0P	18	19 5/8	18	33	16	97-9W5(*)-0P	18	20 1/2	20 1/2	45	16
97-8G5(*)-0P	18	19 5/8	20	34	16	98-8W6(*)-0P	18	19 5/8	22 1/2	47	12
97-855(*)-0P	18	19 5/8	20	34	16	98-8W7(*)-0P	18	19 5/8	24 1/2	48	12
98-8G7(*)-0P	18	19 5/8	24	36	12	98-887(*)-0P	18	19 5/8	24 1/2	48	12
98-857(*)-0P	18	19 5/8	24	36	12	98-8W8(*)-0P	18	19 5/8	26 1/2	50	8
98-8G8(*)-0P	18	19 5/8	26	43	8	98-888(*)-0P	18	19 5/8	26 1/2	50	8
98-858(*)-0P	18	19 5/8	26	43	8	98-8W9(*)-0P	18	19 5/8	28 1/2	52	8
98-8G9(*)-0P	18	19 5/8	28	46	8	98-889(*)-0P	18	19 5/8	28 1/2	52	8
98-8G10(*)-0P	18	19 5/8	30	50	8	98-8812(*)-0P	18	19 5/8	34 1/2	58	8
98-8G12(*)-0P	18	19 5/8	34	52	8	98-8W12(*)-0P	18	19 5/8	34 1/2	58	8
(*) - TXV/Refrigerant Character						(*) - TXV/Refrigerant Character					

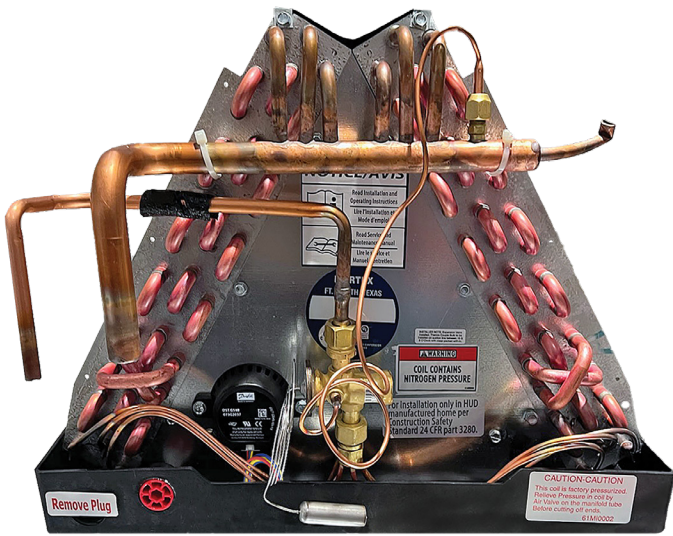

NOTE

Most Mortex coils are shipped from the factory with a TXV metering device. The TXV sensing bulb is not mounted due to potential heat damage and differences in bulb location in the field. After the suction and liquid line have been properly connected to the coil, the sensing bulb can be mounted on a horizontal section of the suction line if possible. Due to space limitations in some manufactured housing applications, the sensing bulb may have to be mounted on a vertical section of the suction line (See Figure C). If mounted vertically, the sensing bulb should be located at least 6" away from and bend (elbow) and on the opposite side from the plane of the bend (See Figure D). The sensing bulb should be insulated using the thermal insulation to isolate it from the effects of the surrounding ambient temperature.

⚠ CAUTION

All coils are shipping from factory pressured with nitrogen and do not contain refrigerant. Relieve nitrogen pressure before opening the refrigerant circuit.

Mortex coils and other accessories installed when air conditioning is added to manufactured housing furnaces must comply with HUD regulations requiring third party approvals. Certified efficiency and capacity ratings as required by HUD / DOE for Mortex coils matched to outdoor units are listed in the current AHRI directory under Summit Manufacturing. These certified ratings are based on air quantities consistent with those that are encountered in typical manufactured housing air conditioning and heat pump applications.

⚠ WARNING

This coil (Model Series 96 - 98) is a partial unit air conditioner, complying with partial unit requirements of Standard UL 60335-2-40 / CSA C22.2 No. 60335-2-40, and must only be connected to other units that have been confirmed as complying to corresponding partial unit requirements of Standard UL 60335-2-40 / CSA C22.2 No. 60335-2-40.

⚠ WARNING

FIRE OR REFRIGERANT HIGH PRESSURE HAZARD

Failure to follow the safety warnings exactly could result in serious injury, death, or property damage.

A fire or refrigerant high pressure hazard may result causing property damage, personal injury or loss of life.



⚠ WARNING

RISK OF FIRE

This coil is equipped with a refrigerant leak detector for safety and with electrically powered safety measures. To be effective, the unit must be electrically powered at all times after installation, other than when servicing.

⚠ CAUTION

This product must be installed in strict compliance with the installation instructions and any applicable local, state, and national codes including, but not limited to building, electrical, and mechanical codes.

⚠ WARNING

RISK OF FIRE

All Mortex coils must be installed in a coil cabinet or furnace coil compartment for the refrigerant leak detection system to function properly.

⚠ WARNING

Improper installation may create a condition where the operation of the product could cause personal injury or property damage.

Improper installation, adjustment, alteration, service or maintenance can cause injury or property damage. Refer to this manual for assistance; or for additional information consult a qualified contractor, installer, or service agency.



This is a safety alert symbol. When you see this symbol on labels or in manuals, be alert to the potential for personal injury.

Understand and pay particular attention to the signal words **DANGER, WARNING, or CAUTION.**

DANGER: Indicates an imminently hazardous situation, which if not avoided, **will result in death or serious injury.**

WARNING: Indicates a potentially hazardous situation, which if not avoided, **could result in death or serious injury.**

CAUTION: Indicates a potentially hazardous situation, which if not avoided, **may result in minor or moderate injury.** It is also used to alert against unsafe practices and hazards involving property damage.

Safety Requirements

1. This coil should be installed in accordance with all national and local building/safety codes and requirements, local plumbing and waste water codes, and other applicable codes. In the absence of local codes, install in accordance with the following codes.
 - Standard for the Installation of Air Conditioning and Ventilating Systems (NFPA 90A)
 - Standard for the Installation of Warm Air Heating and Air Conditioning Systems (NFPA 90B)
 - All local codes (State, City, and Township)

NOTE: All applicable codes take precedence recommendations made in these instructions. Mortex Products, Inc. assumes no responsibility for coils that are installed in violation of any code or regulation.

2. Coil must be installed according to the above listed codes or the instructions in this manual.
3. Failure to carefully read and follow all instructions in this manual can result in a malfunction that can lead to death, personal injury, and/or property damage.
4. Installing and servicing cooling coils can be hazardous due to high pressure, sub-zero refrigerant temperatures and/or hot water.
5. Only trained and qualified personnel should install repair or service heating/cooling coils. Untrained service personnel can perform basic maintenance functions such as cleaning of exterior surfaces and replacing the air filters. Observe all precautions in the manual and on the attached labels when servicing this coil.
6. These instructions cover minimum requirements and conform to existing national standards and safety codes. In some cases, these instructions exceed certain local codes and ordinances, especially those who have not kept up with changing home and/or HUD construction practices. These instructions are to be followed and are the minimum requirement for a safe installation.
7. Check that cabling will not be subject to wear, corrosion, excessive pressure, vibration, sharp edges or any other adverse environmental effects. The check shall also take into account the effects of aging or continual vibration from sources such as compressors or fans.
8. Installation, servicing and maintenance must only be performed by qualified service personnel that are licensed by the state to install, service, and repair HVAC equipment and those who have successfully completed a course in handling, installing, commissioning, maintenance, servicing, repairing,

decommissioning, and disposing of equipment using a flammable refrigerant offered by an accredited national training organization or the manufacturer of the equipment.

9. This coil must not be operated with the access panel removed.
10. This coil is for use at elevations of 10,000 ft (3,048 m) or less.
11. This coil is not to be used by persons (including children) with reduced physical, sensory, or mental capabilities, or lack of experience and knowledge, unless they have been given supervision and instruction concerning use of this coil by a person responsible for their safety. Children must not be allowed to play with this coil.
12. The use of dropped ceilings for return air is not permitted for this coil.
13. Sealed electrical components must be replaced when they fail.
14. Intrinsically safe components must be replaced when they fail.
15. **Safely Commissioning of the System**
 - Ensure that the floor area is sufficient for the refrigerant charge or that the ventilation duct is assembled in a correct manner.
 - Connect the pipes and carry out a leak test before charging with refrigerant.
 - Check safety equipment before putting into service.

Proper Safe Working Procedures for Equipment Using Flammable Refrigerants

Prior to beginning work on systems containing flammable refrigerants, safety checks are necessary to ensure that the risk of ignition is minimized. For repair to the refrigerating system, the following steps must be completed prior to conducting work on the system.

1. Work shall be undertaken under a controlled procedure so as to minimize the risk of a flammable gas or vapor being present while the work is being performed.
2. All maintenance staff and others working in the local area shall be instructed on the nature of work being carried out. Work in confined spaces shall be avoided.
3. The area shall be checked with an appropriate refrigerant detector prior to and during work, to ensure the technician is aware of potentially toxic or flammable atmospheres. Ensure that the leak detection equipment being used is suitable for use with all applicable refrigerants (i.e.: non-sparking, adequately sealed or intrinsically safe).
4. If any hot work is to be conducted on the refrigerating equipment or any associated parts, appropriate fire extinguishing equipment shall be available to hand. Have a dry powder or CO₂ fire extinguisher adjacent to the charging area.
5. No person performing work on a refrigerating system which involves exposing any pipe work shall use any sources of ignition in such a manner that it may lead to the risk of fire or explosion. All possible ignition sources, including cigarette smoking, should be kept sufficiently far away from the site of installation, repairing, removing and disposal, during which refrigerant can possibly be released to the surrounding space. Prior to work taking place, the area around the equipment is to be surveyed to make sure that there are no flammable hazards or ignition risks. "No Smoking" signs shall be displayed.
6. Ensure that the area is in the open or that it is adequately ventilated before breaking into the system or conducting any hot work. A degree of ventilation shall continue during the period that the work is carried out. The ventilation should safely disperse any released refrigerant and preferably expel it externally into the atmosphere.
7. Where electrical components are being changed, they shall be fit for the purpose and to the correct specification. At all times,

the manufacturer's maintenance and service guidelines shall be followed. If in doubt, consult the manufacturer's technical department for assistance.

8. The following checks shall be applied to installations using flammable refrigerants:
- The actual refrigerant charge is in accordance with the room size within which the refrigerant containing parts are installed.
 - Marking to the equipment continues to be visible and legible. Markings and signs that are illegible shall be corrected;
 - Refrigerating pipe or components are installed in a position where they are unlikely to be exposed to any substance which may corrode refrigerant containing components, unless the components are constructed of materials which are inherently resistant to being corroded or are suitably protected against being so corroded.

9. Detection of Flammable Refrigerants

Under no circumstances shall potential sources of ignition be used in the searching for or detection of refrigerant leaks. A halide torch (or any other detector using a naked flame) shall not be used.

The following leak detection methods are deemed acceptable for all refrigerant systems.

Electronic leak detectors may be used to detect refrigerant leaks, but in the case of flammable refrigerants, the sensitivity may not be adequate, or may need re-calibration. (Detection equipment shall be calibrated in a refrigerant-free area.) Ensure that the detector is not a potential source of ignition and is suitable for the refrigerant used. Leak detection equipment shall be set at a percentage of the LFL of the refrigerant and shall be calibrated to the refrigerant employed, and the appropriate percentage of gas (25 % maximum) is confirmed.

Leak detection fluids are also suitable for use with most refrigerants, but the use of detergents containing chlorine shall be avoided as the chlorine may react with the refrigerant and corrode the copper pipe-work.

NOTE: Examples of leak detection fluids are:

- bubble method,
- fluorescent method agents.

If a leak is suspected, all naked flames shall be removed/ extinguished.

If a leakage of refrigerant is found which requires brazing, all of the refrigerant shall be recovered from the system, or isolated (by means of shut off valves) in a part of the system remote from the leak. Removal of refrigerant shall be according to Step 10 below.

10. Removal and Evacuation

When breaking into the refrigerant circuit to make repairs or for any other purpose, conventional procedures shall be used. However, for flammable refrigerants, it is important that best practice be followed, since flammability is a consideration. The following procedure shall be adhered to:

- safely remove refrigerant following local and national regulations;
- evacuate;
- purge the circuit with inert gas (optional for A2L);
- evacuate (optional for A2L);
- continuously flush or purge with inert gas when using flame to open circuit; and
- open the circuit.

The refrigerant charge shall be recovered into the correct recovery cylinders. For appliances containing flammable refrigerants, the

system shall be purged with oxygen-free nitrogen to render the appliance safe for flammable refrigerants. This process might need to be repeated several times. Compressed air or oxygen shall not be used for purging refrigerant systems.

For appliances containing flammable refrigerants, purging shall be achieved by breaking the vacuum in the system with oxygen-free nitrogen and continuing to fill until the working pressure is achieved, then venting to atmosphere, and finally pulling down to a vacuum (optional for A2L). This process shall be repeated until no refrigerant is within the system (optional for A2L). When the final oxygen-free nitrogen charge is used, the system shall be vented down to atmospheric pressure to enable work to take place.

The outlet for the vacuum pump shall not be close to any potential ignition sources, and ventilation shall be available.

11. Charging procedures

In addition to conventional charging procedures, the following requirements shall be followed.

- Ensure that contamination of different refrigerants does not occur when using charging equipment. Hoses or lines shall be as short as possible to minimize the amount of refrigerant contained in them.
- Cylinders shall be kept in an appropriate position according to the instructions.
- Ensure that the refrigerating system is earthed prior to charging the system with refrigerant.
- Label the system when charging is complete (if not already).
- Extreme care shall be taken not to overfill the refrigerating system.

Prior to recharging the system, it shall be pressure-tested with the appropriate purging gas. The system shall be leak-tested on completion of charging but prior to commissioning. A follow up leak test shall be carried out prior to leaving the site.

12. Refrigerant Recovery Requirements

When removing refrigerant from a system, either for servicing or decommissioning, it is recommended good practice that all refrigerants are removed safely.

When transferring refrigerant into cylinders, ensure that only appropriate refrigerant recovery cylinders are employed. Ensure that the correct number of cylinders for holding the total system charge is available. All cylinders to be used are designated for the recovered refrigerant and labeled for that refrigerant (i.e: special cylinders for the recovery of refrigerant). Cylinders shall be complete with pressure-relief valve and associated shut-off valves in good working order. Empty recovery cylinders are evacuated and if possible, cooled before recovery occurs.

The recovery equipment shall be in good working order with a set of instructions concerning the equipment that is at hand and shall be suitable for the recovery of the flammable refrigerant. If in doubt, the manufacturer should be consulted. In addition, a set of calibrated weighing scales shall be available and in good working order. Hoses shall be complete with leak-free disconnect couplings and in good condition.

The recovered refrigerant shall be processed according to local legislation in the correct recovery cylinder, and the relevant waste transfer note arranged. Do not mix refrigerants in recovery units and especially not in cylinders.

If compressors or compressor oils are to be removed, ensure that they have been evacuated to an acceptable level to make certain that flammable refrigerant does not remain within the lubricant.

The compressor body shall not be heated by an open flame or other ignition sources to accelerate this process. When oil is drained from a system, it shall be carried out safely.

13. Commissioning of the System

- Ensure that the floor area is sufficient for the refrigerant charge or that the ventilation duct is assembled in a correct manner.
- Connect the pipes and perform a leak test before charging with refrigerant.
- Check safety equipment before putting into service.

14. Maintenance of the Coil

- Ensure sufficient ventilation at the repair place.
- Be aware that malfunction of the equipment may be caused by refrigerant loss and a refrigerant leak is possible.
- Discharge capacitors in a way that won't cause any spark. The standard procedure to short circuit the capacitor terminals usually creates sparks.
- Reassemble sealed enclosures accurately. If seals are worn, replace them.
- Check safety equipment before putting the system into service.

15. Repair of the Coil

- Ensure sufficient ventilation at the repair place.
- Be aware that malfunction of the equipment may be caused by refrigerant loss and a refrigerant leak is possible.
- Discharge capacitors in a way that won't cause any spark.
- When brazing is required, the following procedures shall be performed in the following order:
 - Safely remove the refrigerant following local and national regulations. If the recovery is not required by national regulations, drain the refrigerant to the outside. Take care that the drained refrigerant will not cause any danger. In doubt, one person should guard the outlet. Take special care that drained refrigerant will not float back into the building;
 - Purge the refrigerant circuit with oxygen free nitrogen;
 - Evacuate the refrigerant circuit;
 - Remove parts to be replaced by cutting or brazing.
 - Purge the braze point with nitrogen during the brazing procedure required for repair.
 - Perform a leak test before charging with refrigerant.
- Reassemble sealed enclosures accurately. If seals are worn, replace them.
- Check safety equipment before putting the system back into service.

16. Decommissioning of the Coil (Refer to the last page of this manual for additional information)

- If the safety is affected when the equipment is putted out of service, the refrigerant charge shall be removed before decommissioning.
- Ensure sufficient ventilation at the equipment location.
- Be aware that malfunction of the equipment may be caused by refrigerant loss and a refrigerant leak is possible.
- Remove the refrigerant. If the recovery is not required by national regulations, drain the refrigerant to the outside. Take care that the drained refrigerant will not cause any danger. In doubt, one person should guard the outlet. Take special care that drained refrigerant will not float back into the building.

17. Disposal of the Coil (Refer to the last page of this manual for additional information)

- Ensure sufficient ventilation at the working place.
- Remove the refrigerant. If the recovery is not required by national regulations, drain the refrigerant to the outside. Take care that the drained refrigerant will not cause any danger. In doubt, one person should guard the outlet. Take special care that drained refrigerant will not float back into the building.
- When flammable refrigerants are used,
 - evacuate the refrigerant circuit.
 - purge the refrigerant circuit with oxygen free nitrogen

WARNING

RISK OF FIRE

Do not use means to accelerate the defrosting process or to clean other than those recommended by the manufacturer. The appliance shall be stored in a room without continuously operating ignition sources. (e.g.: open flames, an operating gas appliance, or an operating electric heater.)

Do not pierce or burn.

Be aware that refrigerants may not contain an odor.

WARNING

RISK OF FIRE

Refer to Tables 2 or 3 for the minimum floor area of the conditioned space served by this coil due to the use of an A2L class flammable refrigerant.

WARNING

RISK OF FIRE – FLAMMABLE REFRIGERANT APPLICATIONS

If any refrigerating circuit contains more than 62.6 oz (1.776 kg) of R-454B refrigerant or more than 64.6 oz (1.836 kg) of R-32 refrigerant, an unventilated area where a coil using a flammable refrigerant is installed shall be so constructed that should any refrigerant leak, it will not stagnate and create a fire or explosion hazard.

WARNING

FIRE HAZARD

For coils using A2L refrigerants connected via an air duct system to one or more rooms with a floor area less than shown in Table 2 or 3, those rooms shall be without continuously operating open flames (e.g.: an operating gas appliance) or other potential ignition sources (e.g.: an operating electric heater, hot surfaces). A flame producing device may be installed in the same space if the device is provided with an effective flame arrest.

⚠️ WARNING

FIRE HAZARD

For coils using A2L refrigerants connected via an air duct system to one or more rooms, auxiliary devices which may be a potential ignition source shall not be installed in the duct work. Examples of such potential ignition sources are hot surfaces with a temperature exceeding 1290°F (700°C) and electric switching devices.

For coils using A2L refrigerants connected via an air duct system to one or more rooms, only auxiliary devices approved by the coil manufacturer or declared suitable with the refrigerant shall be installed in connecting ductwork.

GENERAL INSTALLATION INFORMATION

1. **Pressure Check:** All coils should be checked for pressure before leaving the distributor or before installation! If no pressure is present, the coil may have developed a leak during shipment and should be returned to the point of purchase for exchange. To test for pressure on a sweat connection coil, remove the cap or flare nut on the Schrader fitting located on the suction manifold and depress the valve core.
2. The blower and duct system must be properly sized in order to provide adequate cooling and heating performance. Select the correct motor speed tap on the furnace blower to provide the rated airflow required to achieve the rated cooling capacity or upgrade the blower assembly to attain the proper airflow. Return air filters of generous size must be provided to prevent contaminating the coil, blower, and ductwork and to prevent restricting the airflow. Failure to deliver the proper airflow across the indoor coil will cause system and/or component problems, (i.e.: TXV performance problems).
3. It is essential that the indoor coil and outdoor unit be properly matched and charged with the proper amount of refrigerant. Incorrect charge levels will result in inefficient and/or unreliable operation. See more details in installation instructions for the outdoor unit.
4. For optimum performance and efficiency of air conditioning or heat pump coils, adjust system charge to achieve the subcooling as recommended by outdoor unit manufacturers. Procedures will differ between manufacturers
5. It is recommended that the coil be sprayed with a liquid detergent solution and rinsed thoroughly before installation to assure proper drainage of condensate from the coil fins, eliminate water blowoff, and to assure maximum coil performance. If not sprayed, approximately 50 hours of break in time is required to achieve the same results.
6. Install the coil level or sloped slightly toward the drain fittings. If mandated by code, connect drain line to an open drain, but never to a closed sewer. Pitch drain line away from drain pan to assure proper drainage and test the drain lines with water before operating system. This step is mandatory in all manufactured housing installations. Reduction in size of the drain lines is not recommended and often not allowed.
7. A condensate trap installed in the drain lines is recommended for all installations, but is required for draw through installations where the coil is subjected to a negative air pressure to assure proper drainage of condensate from the coil drain pan. A condensate trap is especially important for installations with

⚠️ ATTENTION

An auxiliary drain pan must be installed under the coil and furnace for applications where the coil installed in an attic or above a finished ceiling. The auxiliary drain pan must have its own drain line (trap not required) draining into visible open drain (not a closed sewer) to alert the homeowner/user that the coil drain lines are plugged and need maintenance.

- an electric heat furnace improper drainage can result in a shock hazard.
8. Check all field installed refrigerant connections with an electronic leak detector, halide torch, or soap bubbles.
 9. Refer to installation instructions provided with the outdoor unit, gas or electric furnace, and line sets for completion of system installation.
 10. Preventive maintenance on a heat pump indoor coil is critical to ensure proper airflow across the coils. Low airflow on indoor coils during winter months causes high head pressures and premature compressor damage due to oil breakdown. This problem is normally the result of a dirty air filter. The installer should instruct the homeowner of the importance of keeping filters clean.
 12. **Conditioned Space for Flammable A2L Refrigerants.** When flammable A2L class refrigerants are used, the minimum floor area of the conditioned space the coil serves must comply with Table 2 or 3 to allow a refrigerant leak to disperse and be diluted with air to eliminate the risk of the refrigerant igniting and causing an explosion and/or fire. The minimum floor area must be corrected by an altitude adjustment factor based on the building site ground level altitude. See Table 1 for the altitude adjustment factor for various altitudes and refer to the example below for how to apply the altitude adjustment factor.

Example:

Total System Charge = 2.6 kg of R-454B

Altitude = 2400 m

Min. Conditioned Floor Area (MCFA) from Table 2 = 7.97 m²

Altitude Adjustment Factor (AF) from Table 1 = 1.24

Adjusted MCFA = MCFA x AF

Adjusted MCFA @ 2400 m. altitude = 7.97 m² x 1.24 = 9.88 m²

Altitude Correction Factors									
Altitude (m)	0	100	200	300	400	500	600	700	800
Altitude (ft)	0	328	656	984	1312	1640	1969	2297	2625
AF	1.00	1.01	1.02	1.02	1.03	1.04	1.05	1.06	1.07
Altitude (m)	900	1000	1100	1200	1300	1400	1500	1600	1700
Altitude (ft)	2953	3281	3609	3937	4265	4593	4921	5249	5577
AF	1.08	1.09	1.10	1.11	1.12	1.13	1.14	1.15	1.16
Altitude (m)	1800	1900	2000	2100	2200	2300	2400	2500	2600
Altitude (ft)	5906	6234	6562	6890	7218	7546	7874	8202	8530
AF	1.17	1.18	1.19	1.20	1.21	1.22	1.24	1.25	1.26
Altitude (m)	2700	2800	2900	3000	3100	3200	3400	3600	3700
Altitude (ft)	8858	9186	9514	9842	10171	10499	11155	11811	12139
AF	1.27	1.29	1.30	1.31	1.33	1.34	1.37	1.40	1.42

Table 1: Altitude Adjustment Factors

INSTALLATION WITH ELECTRIC FURNACE

A typical electric furnace installation consists of a coil with a cabinet installed on top of a downflow furnace or a coil inside a cavity of either a downflow or upflow furnace.

The following Mortex installation kits are unique to manufactured housing air conditioning and are required to complete the installation.

1. A Coil Support Bracket (99-3420-04/14) and coil support with Insulation Kit (99-3420-02) is required to support coils in Coleman furnaces where not already installed.
2. Coil & Filter Cabinets (97-BCC-02N) are on all electric furnaces.

WARNING

Contractor must comply with all local, state, and federal codes and regulations when working with gas piping. Personal injury or death may result from improper installations!

Installation Procedure

1. Turn off electrical power to the furnace by turning off breaker(s) in the home's main electrical panel and turning the furnace circuit breakers and any local disconnect switches to the OFF position.

WARNING: Furnace may be connected to more than one electrical supply circuit. Do not use furnace disconnect only. Check power at furnace to verify electrical power is off.

2. Remove filter at top of furnace cabinet (Nordyne & Coleman only).
3. Remove refrigerant line knockout at top of furnace (Mortex & Nordyne only).
4. Install insulation if needed.
5. Attach drain pan gasket provided with coil to underside of coil drain pan and center coil on furnace (See Figure A).
6. Route low voltage wiring, refrigerant lines, and condensate drain lines through floor penetration.

NOTE: If drain hose is below 40°F during installation, warm before expanding and/or forming.

7. Form a 3" deep trap using field supplied tape and the provided flexible drain hose and connect hose to the condensate drain fitting on the coil drain pan with the provided clamp (See Figure B). The most efficient use of the drain hose is to form a "P" trap under the house.

NOTE: All applications with a draw-through coil must have a condensate trap in the drain line due to the coil being operated in a negative air pressure which will result in poor condensate drainage.

8. With the coil in place, seal off any openings at top or bottom of furnace with the provided aluminum adhesive tape to prevent air leakage or air bypass.
9. Install a return air filter.
10. Remove the **Minimum Conditioned Space/Refrigerant Class** adhesive label from the plastic bag that is attached to the coil header and affix it to the exterior of the coil access panel so the label is visible when the coil access panel is in place.
11. Install any furnace or coil access panels that have been removed.

12. Restore electrical power to the furnace by turning the breaker(s) in the main electrical, furnace circuit breakers, and any local disconnect switches to the ON position.

INSTALLATION WITH GAS FURNACE

A typical downflow gas furnace installation consists of a coil without a cabinet installed in the cavity of a downflow furnace. Coils with plastic drain pans are not suitable for upflow oil furnaces.

Installation Procedure

1. Turn off the electrical power to furnace.
2. Remove the lower front panel of the furnace and re-route any gas piping that is in front of coil compartment as required to install coil.
3. Remove the coil cover panel(s).
4. Remove knockouts in the furnace for routing of refrigerant lines, low voltage wiring, and condensate drain.
5. Attach the provided drain pan gasket provided with the coil to underside of coil pan and center coil in coil cavity (See Figure A).
6. Connect the drain hose to the condensate fitting on the coil drain pan and secure with the provided clamp (See Figure B).

ATTENTION

Do not install a coil containing refrigerant on a gas furnace that will be operated during the heating season without attaching the refrigerant lines to the coil. Possible coil damage will result from excessive pressure build up during heating operation.

7. Remove the knockouts from coil cover panel(s), cut the fiberglass insulation covering the openings, and reinstall the cover panel(s).
8. Seal any gaps in the interior panel door and around refrigerant lines with the provided silver backed tape.
9. Connect refrigerant lines and make sure all connections are tight and without leaks.
10. Reconnect the gas piping if it was disconnected and seal off any openings at bottom of furnace. National, state and local codes must be followed.
11. Install a return air filter if one is not already located in the furnace.
12. Remove the **Minimum Conditioned Space/Refrigerant Class** adhesive label from the plastic bag that is attached to the coil header and affix it to the exterior of the furnace door so the label is visible when the furnace door is in place.
13. Replace front furnace door.
14. Turn on the gas and electrical supplies and perform a final system check.

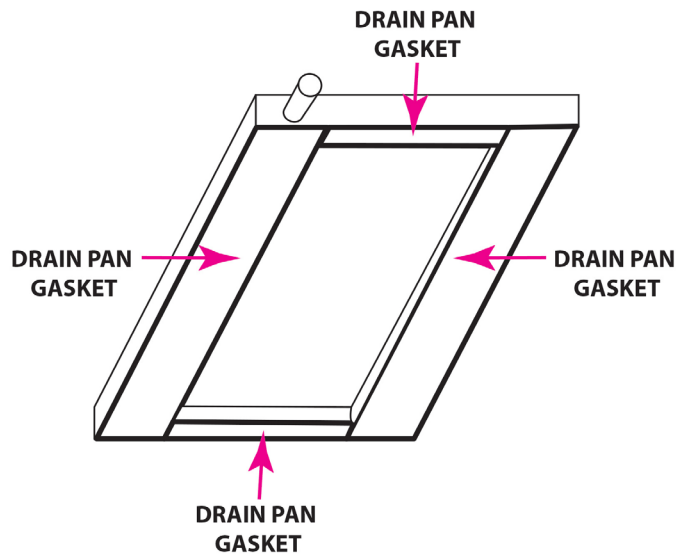

Figure A: Drain Pan Gaskets

Note: Review the following instructions before installing the coil in the furnace.

1. The accessory package to be used with a manufactured/mobile home plastic drain pan contains a 90° elbow that can be screwed into the left drain connections and turned down to exit the furnace.
2. Only hand tighten this fitting. Over tightening can result in cracks in the drain pan.
3. The enclosed drain hose will slip over the fitting or a standard PVC fitting can be used if code requires one.
4. The right drain connection is plugged to prevent flow unless a secondary drain is required.
5. A filed supplied straight fitting can be used for the auxiliary drain where required.
6. Remove auxiliary drain plug, insert fitting, and turn down using a standard 3/4" PVC elbow.
7. Installation of a collapsible hose the main and auxiliary condensate drain connections is required as show below.
8. Slip 1" ID section of hose onto the 90° drain fitting.
9. The hose may be very tight, but it will stretch as it is slipped onto the fitting.
10. The drain hose can be in place during installation if the clamps are securely fastened.
11. If the drain hose must be removed to complete the installation, make sure the hose is reattached and securely fastened with the clamps before completing the installation.

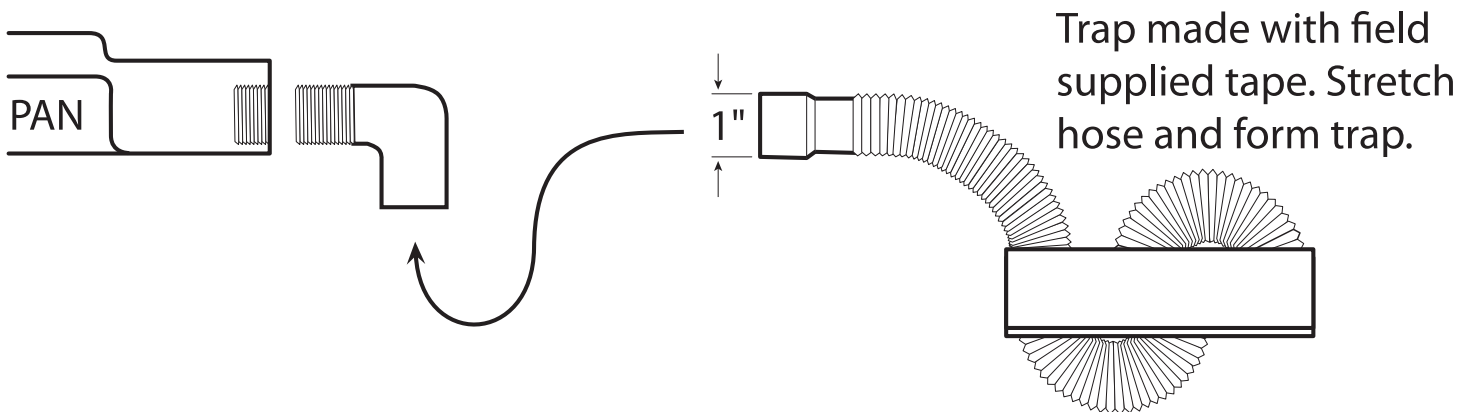

Figure B: Condensate Drain Hose and Trap

SPECIAL PIPING INSTRUCTIONS DUE TO THE USE OF AN A2L CLASS FLAMMABLE REFRIGERANT



WARNING

RISK OF FIRE

This following precautions must be taken for the refrigerant piping due to this coil being used with an A2L class flammable refrigerant.

Piping material, pipe routing, and installation shall, including protection from physical damage in operation and service, be in compliance with national and local codes and standards, such as ASHRAE 15, IAPMO Uniform Mechanical Code, ICC International Mechanical Code, or CSA B52 shall be observed. All field joints shall be accessible for inspection prior to being covered or enclosed.

The installation of pipe-work shall be kept to a minimum.

Due to this coil being used with an A2L class flammable refrigerant, the refrigerant pipe-work shall not be installed in an unventilated space if that space is smaller than the minimum floor area shown in Table 2 or 3 unless there are no joints in the pipe-work in that space (e.g.: pipework that is run in walls or between floors).

Since refrigerant line length affects the final refrigerant charge, the final refrigerant charge after field charging of the system must be noted and used when determining the minimum floor area of the conditioned space from Table 2 or 3.

Mechanical connections shall be accessible for maintenance purposes.

For appliances using flammable refrigerants, all joints made in the installation between parts of the refrigerating system, with at least one part charged, shall be made in accordance with the following:

- A brazed, welded, or mechanical connection shall be made before opening the valves to permit refrigerant to flow between the refrigerating system parts. A vacuum valve shall be provided to evacuate the interconnecting pipe or any uncharged refrigerating part.
- Mechanical connectors used indoors shall comply with ISO 14903 or UL 207 Annex A (USA only). When mechanical connectors are reused indoors, sealing parts shall be renewed. When flared joints are reused indoors, the flare part shall be refabricated.
- Refrigerant tubing shall be protected or enclosed to avoid damage.
- Flexible refrigerant connectors (such as connecting lines between the indoor and outdoor unit) that may be displaced during normal operation shall be protected against mechanical damage.

For installations with field applied joints that are exposed in the occupied space, these joints shall be at least one of the following:

- Mechanical joints in compliance with ISO 14903 or UL 207 Annex A (USA only)
- Welded or brazed joints; or
- Joints in enclosures that vent to the unit or to the outside.

Provision shall be made for expansion and contraction of long runs of piping.

Protection devices, piping, and fittings shall be protected as far as possible against adverse environmental effects, for example,

the danger of water collecting and freezing in relief pipes or the accumulation of dirt and debris.

Piping in refrigeration systems shall be so designed and installed to minimize the likelihood of hydraulic shock damaging the system.

After completion of field piping for split systems, the field pipework shall be pressure tested with an inert gas and then vacuum tested prior to refrigerant charging, according to the following requirements:

- The minimum test pressure for the low side of the system shall be the low side design pressure as stated on the coil rating plate and the minimum test pressure for the high side of the system shall be the high side design pressure as stated on the coil rating plate, unless the high side of the system cannot be isolated from the low side of the system in which case the entire system shall be pressure tested to the low side design pressure.
- The test pressure after removal of pressure source shall be maintained for at least 1 hour with no decrease of pressure indicated by the test gauge, with test gauge resolution not exceeding 5% of the test pressure.
- During the evacuation test, after achieving a vacuum level specified in the manual or less, the refrigeration system shall be isolated from the vacuum pump and the pressure shall not rise above 1500 microns within 10 min. The vacuum pressure level shall be the lesser of 500 microns or the value required for compliance with national and local codes and standards, which may vary between residential, commercial, and industrial buildings.

Field-made refrigerant joints indoors shall be tightness tested. The test method shall have a sensitivity of 5 grams per year of refrigerant or better under a pressure of at least 0.25 times the maximum allowable pressure. No leak shall be detected.

SPECIAL CONSIDERATIONS FOR SELECTING HEAT PUMP COILS

The selection of indoor coils for heat pump outdoor units is much more critical than the selection of indoor coils for straight air conditioning units. The differences are as follows:

1. Only indoor coils with flow control devices with a check valve may be used with outdoor heat pump units. These devices permit reverse refrigerant flow in the coils when the system is operating in the heating mode. All Mortex TXV's have a built-in check valve making them heat pump capable when matched with the proper AHRI rated outdoor unit.

NOTE: Cap tube or non-check valve piston metering device coils must not be used in heat pump applications.

2. Matching of indoor coils for heat pumps demands that the heat rejection capacity, internal volume, and equivalent metering device of the matched coil be equivalent to that of the smallest internal volume coil the outdoor unit manufacturer recommends for that outdoor unit.
3. It is important that selection be based on Mortex's recommendation for the specific coil, metering device, and outdoor heat pump unit of a specific make, series, and model number.
4. Failure to comply with the proper selection requirements will affect efficiency, charging, and reliability and may result in damage to the system or system components.
5. The matching of specific indoor heat pump coils with specific outdoor heat pump units as certified in the heat pump section of the current AHRI Directory will assure proper and efficient operation of heat pump systems (See <https://.ahridirectory.org>).

SPECIAL INSTRUCTIONS FOR CHARGING HEAT PUMP COILS

Specific instructions for refrigerant charging of a heat pump system as recommended by the outdoor unit manufacturer should be followed. These instructions will vary from different manufacturers, but in general are as follows:

1. For a TXV in the indoor coil, use the liquid subcooling method in the cooling mode. Measure the liquid line pressure and temperature at the outdoor unit liquid service valve. Compare measurements to a refrigerant temperature/pressure chart to determine the liquid subcooling. Adjust the refrigerant charge to achieve outdoor unit manufacturer's recommended liquid subcooling level.
2. If problems using the outdoor manufacturers suggested charging method are encountered, the technician should contact the outdoor unit manufacturer for assistance.

METERING DEVICE INSTRUCTIONS FOR TXV COILS

All Mortex TXV's have a built-in check for heat pump applications and can be used on both A/C and heat pump applications.

Mortex coils are shipped with one of the following TXV's depending on the capacity.

R72DB0101DF: R-32, 1.5 – 3.0 Ton, 15% Bleed,
Inlet: Male Rotolock, Outlet: Female Swivel Nut

R72DB0102DF: R-32, 3.0 – 5.0 Ton, 15% Bleed,
Inlet: Male Rotolock, Outlet: Female Swivel Nut

R72DB0103DF: R-454B, 1.5 – 3.0 Ton, 15% Bleed,
Inlet: Male Rotolock, Outlet: Female Swivel Nut

R72DB0104DF: R-454B, 3.0 – 5.0 Ton, 15% Bleed,
Inlet: Male Rotolock, Outlet: Female Swivel Nut

Mortex coils are shipped from the factory with the TXV mounted on the distributor body, but the sensing bulb is shipped unattached to allow the suction line to be brazed to the coil suction stub without the heat from the torch damaging the TXV. If possible, the sensing bulb should be installed on the horizontal run of the suction line if as shown in Figure C. The sensing bulb clamp must be tightened sufficiently to provide good contact between the sensing bulb and the copper suction line.

If the sensing bulb must be mounted on a vertical section of the suction line, the sensing bulb should be located at least 6 inches from any bend and mounted on the side of the line opposite the plane of the bend and the sensing bulb should be positioned with the capillary tube at the top (See Figure D). The bulb should be insulated using thermal insulation to protect it from the effect of the surrounding ambient temperature.

Mortex coils have a Chatleff type distributor body that accepts a screw-on TXV. All TXV's have a direct relationship to the specific outdoor unit the coil is matched with. Refer to the AHRI Directory (www.ahridirectory.org) listing for the specific coil and outdoor unit match-up to determine which TXV is required to attain the AHRI rated capacity and efficiency.

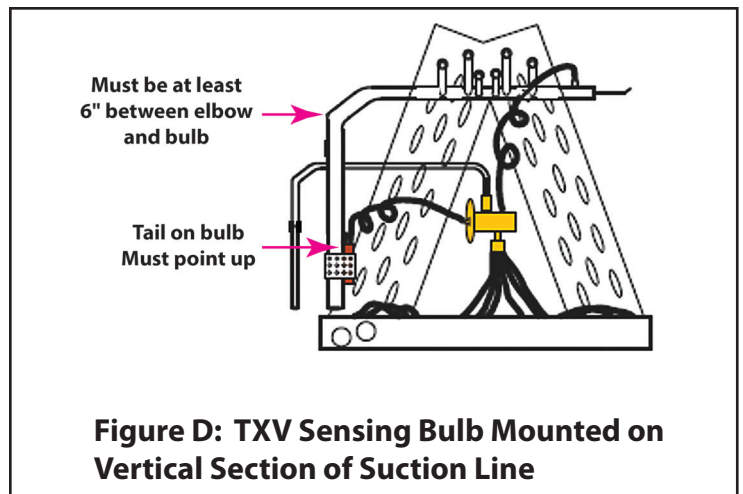
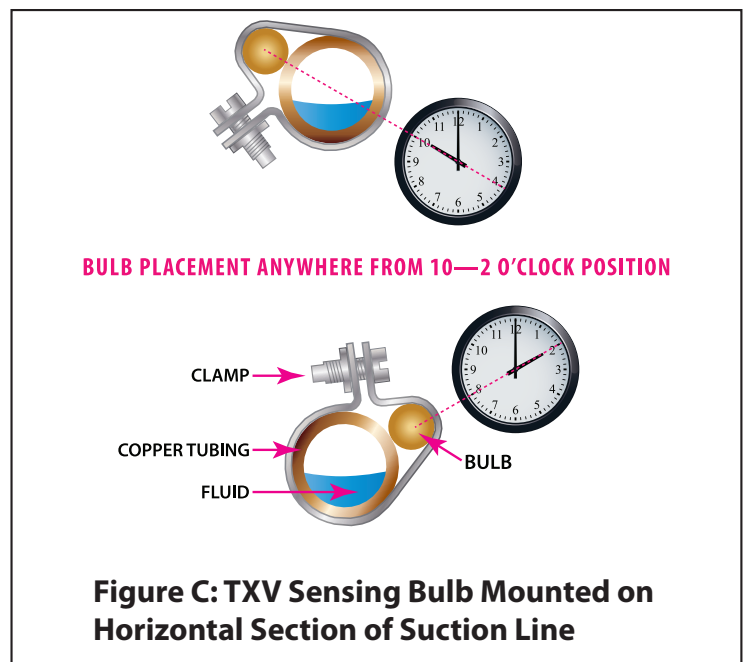

Refrigerant Recovery Requirements

When removing refrigerant from a system, either for servicing or decommissioning, it is recommended good practice that all refrigerants are removed safely.

When transferring refrigerant into cylinders, ensure that only appropriate refrigerant recovery cylinders are employed. Ensure that the correct number of cylinders for holding the total system charge is available. All cylinders to be used are designated for the recovered refrigerant and labeled for that refrigerant (i.e: special cylinders for the recovery of refrigerant). Cylinders shall be complete with pressure-relief valve and associated shut-off valves in good working order. Empty recovery cylinders are evacuated and, if possible, cooled before recovery occurs.

The recovery equipment shall be in good working order with a set of instructions concerning the equipment that is at hand and shall be suitable for the recovery of the flammable refrigerant. If in doubt, the manufacturer should be consulted. In addition, a set of calibrated weighing scales shall be available and in good working order. Hoses shall be complete with leak-free disconnect couplings and in good condition.

The recovered refrigerant shall be processed according to local legislation in the correct recovery cylinder, and the relevant waste

transfer note arranged. Do not mix refrigerants in recovery units and especially not in cylinders.

If compressors or compressor oils are to be removed, ensure that they have been evacuated to an acceptable level to make certain that flammable refrigerant does not remain within the lubricant. The compressor body shall not be heated by an open flame or other ignition sources to accelerate this process. When oil is drained from a system, it shall be carried out safely.

Complete the refrigerant charge weight field on the outdoor unit rating plate when refrigerant charging is completed. Follow the outdoor unit installation instructions for handling, installation, cleaning, and disposal of the refrigerant.

REFRIGERANT LEAK DETECTION SYSTEM

IMPORTANT: This coil is equipped with a refrigerant leak detection system consisting of a refrigerant sensor with integral relays to perform the necessary leak mitigation if a refrigerant leak is detected by the sensor (see Figure E). The refrigerant detection system wiring harness pigtail wires must be properly connected to the furnace, thermostat, and outdoor unit low voltage control circuit. (See Figure F).

Important Note: The refrigerant detection system sensor wiring harness plug must be pointing down or horizontal. If the plug is pointing up, condensate could collect in the plug and result in corrosion and/or operational issues.

Refrigerant Leak Alarm Output

The coil's refrigerant leak sensor has an alarm output signal that can be used as an input to a building management system or smart thermostat to alert the homeowner or user that the refrigerant detection system has detected a refrigerant leak and is in the leak mitigation mode. There is an ORANGE low voltage pigtail wire in the sensor harness labeled "ALARM". When the sensor is powered and no refrigerant leak is detected, the ORANGE "ALARM" pigtail wire is energized with 24 VAC indicating normal operation. When the refrigerant leak detection system detects a refrigerant leak and enters the leak mitigation mode (indoor blower energized and outdoor unit disabled), the ORANGE "ALARM" pigtail wire will be de-energized (0 VAC). The ORANGE "ALARM" pigtail wire is capped with a wire nut from the factory. Remove this wire nut and connect it to the building management system or smart thermostat as required if a refrigerant leak alert is desired. The building management system or smart thermostat shall be programmed to accept the reverse logic alarm signal (24 VAC – Normal; 0 VAC – Refrigerant Leak).

If a 24 VAC output when a refrigerant leak is detected is required to activate a warning light or audible alarm, the ORANGE "ALARM" pigtail wire shall be connected to the coil of a field supplied relay with normally closed contacts and a 24 VAC coil. An 18 AWG minimum wire from the furnace 24 VAC common circuit shall be connected to the other side of the relay coil. An 18 AWG minimum wire from the furnace 24 VAC "R" transformer circuit shall be connected to the terminal for one side of the normally closed relay contacts and an 18 AWG minimum wire to the warning light or audible alarm shall be connected to terminal for the other side of the normally closed relay contacts. All field supplied wiring shall be protected from damage. When no refrigerant leak is detected, the relay will be energized and the relay contacts will be open, disconnecting the 24 VAC signal to the warning light or audible alarm. When a refrigerant leak is detected, the relay will be de-

energized and the contacts will close sending a 24 VAC signal to the warning light or audible alarm.

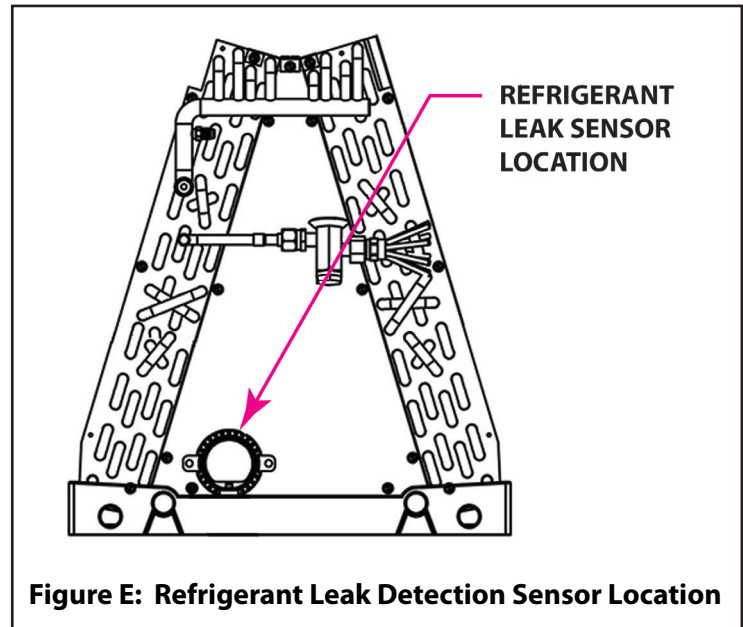

Refrigerant Detection System Wiring Connections

Make sure the leak detection system sensor wiring harness is plugged into the mating plug on the sensor. Route the sensor wiring harness through the bushing in the coil enclosure or coil cabinet so it is outside the coil enclosure or coil cabinet. Connect the sensor harness pigtail wires to the furnace, thermostat, and outdoor unit low voltage control circuit as follows.

1. Connect the RED sensor pigtail wire labeled "R" to the "R" terminal on the furnace low voltage terminal block.
2. Connect the BLACK sensor pigtail wire labeled "COM" to the "C" or "COM" terminal on the furnace low voltage terminal block. Confirm the outdoor unit compressor is operating.
3. Connect the YELLOW sensor pigtail wire labeled "Y-Tstat" to the "Y" or "Y1" terminal on the furnace low voltage terminal block. If the furnace low voltage terminal block does not have a "Y" or "Y1" terminal, connect the YELLOW sensor pigtail wire to the low voltage wire coming from the "Y" or "Y1" terminal on the thermostat.
4. Connect the WHITE sensor pigtail wire labeled "Y-CC" to the low voltage wire coming from the "Y" or "Y1" terminal on the outdoor unit. If the outdoor unit does not have a "Y" or "Y1" terminal, connect the WHITE sensor pigtail wire labeled "Y-CC" to the wire coming from the YELLOW low voltage pigtail on the outdoor unit that is connected to the compressor contactor coil.

NOTE: Do not connect the WHITE sensor pigtail wire labeled "Y-CC" to the common (COM) wire coming from the outdoor unit compressor contactor coil.

5. Connect the BLUE sensor pigtail wire labeled "G" to the "G" terminal on the furnace low voltage terminal block. Set the thermostat to the desired operating mode and temperature. approved replacement from the manufacturer.
6. If a refrigerant leak alert is desired and a building management system or smart thermostat capable of providing that alert is being used, removed the wire nut from the end of the ORANGE pigtail wire labeled "ALARM" and connect it to the appropriate building management system or smart thermostat connections. See "Refrigerant Leak Alarm Output" on this page for additional information.

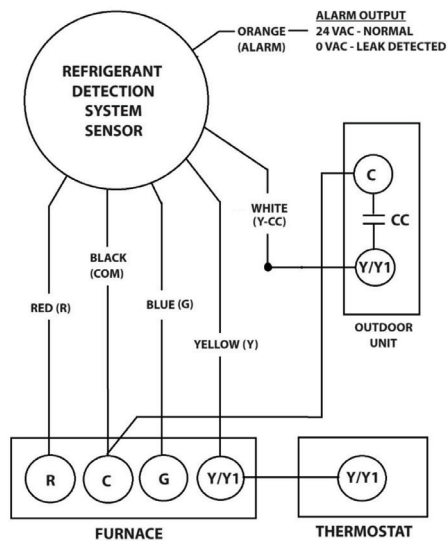

Figure F: Refrigerant Detection System Wiring Connections

Minimum Circulating Airflow for Refrigerant Leak Mitigation

There is a minimum circulating airflow required when the refrigerant leak detection system is operating in the leak mitigation mode. This minimum depends on the total system refrigerant charge and can be found listed in Tables 2 and 3. The refrigerant mitigation system energizes the continuous fan function on the furnace or air handler. The continuous fan CFM (l/s) may need to be increased to achieve the minimum leak mitigation circulating airflow level by changing to a different indoor blower motor speed tap or ECM motor setting that delivers the minimum mitigation airflow level. Refer to the furnace or air handler blower performance tables and wiring diagrams in the manufacturer's installation manual to determine if this adjustment is necessary and if it is determined to be necessary to increase the continuous fan airflow level, follow the instructions in that manual to make the necessary adjustment.

Refrigerant Detection System Sequence of Operation

Should a refrigerant leak occur in the indoor coil, the refrigerant leak detection system will energize the indoor blower and will open the 24VAC circuit to the outdoor unit compressor contactor. The circulation of air will disperse the leaked flammable refrigerant into the conditioned space where it will be diluted to a point where it can no longer be ignited by an ignition source. The indoor blower will continue to operate until 5 minutes after the concentration of the refrigerant at the sensor drops below the sensor's setpoint. Should the concentration of the refrigerant rise above the setpoint of the sensor, the mitigation cycle will repeat until the refrigerant concentration stays below the setpoint of the sensor. The sensor pigtail marked "ALARM" will normally be energized with 24VAC when no leak is detected and will be de-energized when a leak is detected for the purpose of notifying a building management system to issue a refrigerant leak alarm.

Should the sensor fail or if the sensor wiring is damaged or disconnected, the sensor will automatically enter the mitigation mode until the sensor is replaced or the wiring is reconnected or repaired.

Verifying Proper Functioning of Refrigerant Leak Mitigation System

Follow the steps below to verify the proper functioning of the Refrigerant Leak Mitigation System.

1. Remove the coil access panel from the front of the coil or furnace.
2. Locate the black refrigerant sensor located near the bottom front of the coil assembly (see Figure E).

Leak Detected During Cooling Cycle

3. Set the thermostat to "COOL" and the fan switch to "AUTO" and lower the temperature setpoint below the indoor temperature so the system enters the cooling mode.
4. Confirm the outdoor unit compressor is operating.
5. Within 30 seconds of the compressor starting, release a small amount of refrigerant on the refrigerant sensor to activate the leak mitigation mode.
6. Confirm the outdoor unit compressor and fan motor shut down and the indoor blower continues to operate.
7. Confirm the indoor blower is energized and 24V is not present at the refrigerant leak detection sensor pigtail labeled "ALARM".
8. Confirm the outdoor unit compressor and fan motor are reenergized approximately 5 minutes after the flow of refrigerant near the sensor has ended and that the indoor blower continues to operate.

Leak Detected During the OFF Cycle

9. Set the thermostat to the "OFF" position and wait until the outdoor unit compressor and fan motor stop and indoor blower stops.
10. Release a small amount of refrigerant on the refrigerant sensor to activate the leak mitigation mode.
11. Confirm the indoor blower is energized and 24V is not present at the coil pigtail marked "ALARM".
12. Confirm the indoor blower shuts down after approximately 5 minutes after the flow of refrigerant on the refrigerant sensor has ended.
13. If the Refrigerant Leak Mitigation System does not operate as stated above, check for loose wiring connections or replace the refrigerant sensor.
14. Reinstall the coil access panel on the coil or furnace.
15. Set the thermostat to the desired operating mode and temperature.

If the leak detection system does not function properly when subjected to the above procedure, check for miswiring of the system. If the wiring connections are found to be correct per the coil or air handler wiring diagram, replace the sensor with an approved replacement from the manufacturer.

Leak Detection Sensor Replacement

When the refrigerant leak detection system sensor fails or reaches the end of its life, the leak detection system will enter and remain in the leak mitigation mode even though there is no refrigerant leak present. If the leak detection system continues to operate in the mitigation mode even when a refrigerant leak isn't indicated by a portable refrigerant leak detector, replace the sensor with an approved replacement from the air coil manufacturer. Disconnect the wiring harness connector from the failed sensor and remove the sensor mounting screws. Discard the failed sensor. Mount the replacement sensor in the same location as the failed sensor that was removed and connect the sensor wiring harness connector to the sensor. Verify the proper function of the refrigerant leak

mitigation system using the “**Verifying Proper Functioning of Refrigerant Leak Mitigation System**” procedure above.

IMPORTANT: Mortex may source sensors from various manufacturers that have a different wiring harness connection. A wiring adapter may be necessary to allow the replacement sensor to connect the sensor wiring harness. The wiring adapter will be provided with the replacement sensor. Alternate mounting holes are provided to accommodate the various approved sensors. Only use a replacement sensor approved by and provided by Mortex to assure proper operation and compatibility.

Only the following replacement refrigerant sensors may be used for Mortex products:

R-32 Refrigerant: R68ALL001

R-454B Refrigerant: R68ALL002

IMPORTANT: The refrigerant detection system sensor wiring harness plug must be pointing down or horizontal. If the plug is pointing up, condensate could collect in the plug and result in corrosion and/or operational issues.

Total System Refrigerant Charge (kg)	Total System Refrigerant Charge (oz)	Total System Refrigerant Charge (lb)	Min. Area of Conditioned Space (m ²)	Min. Area of Conditioned Space (ft ²)	Min. Air-Flow (meter ³ /hr)	Min. Air-Flow (liter/s)	Min. Air-Flow (CFM)
1.776 kg or less	62.6 oz or less	3.91 lb or less	No Minimum	No Minimum	No Minimum	No Minimum	No Minimum
1.78	63	3.92	5.47	59	180	50	106
1.92	68	4.22	5.88	63	194	54	114
2.05	72	4.52	6.30	68	208	58	122
2.19	77	4.82	6.72	72	222	62	131
2.32	82	5.12	7.14	77	236	65	139
2.46	87	5.42	7.56	81	249	69	147
2.60	92	5.72	7.97	86	263	73	155
2.73	96	6.02	8.39	90	277	77	163
2.87	101	6.32	8.81	95	291	81	171
3.00	106	6.62	9.23	99	305	85	179
3.14	111	6.92	9.65	104	318	88	187
3.28	116	7.22	10.06	108	332	92	195
3.41	120	7.52	10.48	113	346	96	204
3.55	125	7.82	10.90	117	360	100	212
3.69	130	8.12	11.32	122	374	104	220
3.82	135	8.42	11.74	126	387	108	228
3.96	140	8.73	12.15	131	401	111	236
4.09	144	9.03	12.57	135	415	115	244
4.23	149	9.33	12.99	140	429	119	252
4.37	154	9.63	13.41	144	442	123	260
4.50	159	9.93	13.83	149	456	127	269
4.64	164	10.23	14.24	153	470	131	277
4.77	168	10.53	14.66	158	484	134	285
4.91	173	10.83	15.08	162	498	138	293
5.05	178	11.13	15.50	167	511	142	301
5.18	183	11.43	15.92	171	525	146	309
5.32	188	11.73	16.33	176	539	150	317
5.45	192	12.03	16.75	180	553	154	325
5.59	197	12.33	17.17	185	567	157	333
5.73	202	12.63	17.59	189	580	161	342
5.86	207	12.93	18.01	194	594	165	350
6.00	212	13.23	18.42	198	608	169	358
6.14	216	13.53	18.84	203	622	173	366
6.27	221	13.83	19.26	207	636	177	374
6.41	226	14.13	19.68	212	649	180	382
6.54	231	14.43	20.10	216	663	184	390
6.68	236	14.73	20.51	221	677	188	398
6.82	240	15.03	20.93	225	691	192	407
6.95	245	15.33	21.35	230	705	196	415
7.09	250	15.63	21.77	234	718	200	423
7.22	255	15.93	22.19	239	732	203	431
7.36	260	16.23	22.60	243	746	207	439
7.50	264	16.53	23.02	248	760	211	447
7.63	269	16.83	23.44	252	774	215	455
7.77	274	17.13	23.86	257	787	219	463
7.90	279	17.43	24.28	261	801	223	471
8.04	284	17.73	24.69	266	815	226	480
8.18	288	18.03	25.11	270	829	230	488
8.31	293	18.33	25.53	275	843	234	496
8.45	298	18.63	25.95	279	856	238	504
8.59	303	18.93	26.37	284	870	242	512
8.72	308	19.23	26.78	288	884	246	520
8.86	312	19.53	27.20	293	898	249	528
8.99	317	19.83	27.62	297	911	253	536

TABLE 2: MINIMUM CONDITIONED SPACE AREA & AIR-FLOW FOR R-454B REFRIGERANT INSTALLATIONS

**NOTES: 1. Applies to fixed ducted systems with continuous air-flow or refrigerant detection systems only.
2. Based on LFL of 0.296 kg/m³**

Total System Refrigerant Charge (kg)	Total System Refrigerant Charge (oz)	Total System Refrigerant Charge (lb)	Min. Area of Conditioned Space (m ²)	Min. Area of Conditioned Space (ft ²)	Min. Air-Flow (meter ³ /hr)	Min. Air-Flow (liter/s)	Min. Air-Flow (CFM)
1.836 kg or less	64.6 oz or less	4.04 lb or less	No Minimum	No Minimum	No Minimum	No Minimum	No Minimum
1.84	65	4.06	5.47	59	180	50	106
1.98	70	4.36	5.87	63	194	54	114
2.11	75	4.66	6.28	68	207	58	122
2.25	79	4.96	6.68	72	220	61	130
2.38	84	5.26	7.08	76	234	65	138
2.52	89	5.56	7.49	81	247	69	145
2.66	94	5.86	7.89	85	260	72	153
2.79	99	6.16	8.30	89	274	76	161
2.93	103	6.46	8.70	94	287	80	169
3.06	108	6.76	9.11	98	300	83	177
3.20	113	7.06	9.51	102	314	87	185
3.34	118	7.36	9.91	107	327	91	193
3.47	123	7.66	10.32	111	341	95	200
3.61	127	7.96	10.72	115	354	98	208
3.75	132	8.26	11.13	120	367	102	216
3.88	137	8.56	11.53	124	381	106	224
4.02	142	8.86	11.94	128	394	109	232
4.15	147	9.16	12.34	133	407	113	240
4.29	151	9.46	12.74	137	421	117	248
4.43	156	9.76	13.15	142	434	121	255
4.56	161	10.06	13.55	146	447	124	263
4.70	166	10.36	13.96	150	461	128	271
4.83	171	10.66	14.36	155	474	132	279
4.97	175	10.96	14.77	159	487	135	287
5.11	180	11.26	15.17	163	501	139	295
5.24	185	11.56	15.57	168	514	143	302
5.38	190	11.86	15.98	172	527	146	310
5.51	195	12.16	16.38	176	541	150	318
5.65	199	12.46	16.79	181	554	154	326
5.79	204	12.76	17.19	185	567	158	334
5.92	209	13.06	17.60	189	581	161	342
6.06	214	13.36	18.00	194	594	165	350
6.20	219	13.66	18.41	198	607	169	357
6.33	223	13.96	18.81	202	621	172	365
6.47	228	14.26	19.21	207	634	176	373
6.60	233	14.56	19.62	211	647	180	381
6.74	238	14.86	20.02	216	661	184	389
6.88	243	15.16	20.43	220	674	187	397
7.01	247	15.46	20.83	224	687	191	405
7.15	252	15.76	21.24	229	701	195	412
7.28	257	16.06	21.64	233	714	198	420
7.42	262	16.36	22.04	237	727	202	428
7.56	267	16.66	22.45	242	741	206	436
7.69	271	16.96	22.85	246	754	209	444
7.83	276	17.26	23.26	250	767	213	452
7.96	281	17.56	23.66	255	781	217	460
8.10	286	17.86	24.07	259	794	221	467
8.24	291	18.16	24.47	263	808	224	475
8.37	295	18.46	24.87	268	821	228	483
8.51	300	18.76	25.28	272	834	232	491
8.65	305	19.06	25.68	276	848	235	499
8.78	310	19.36	26.09	281	861	239	507
8.92	315	19.66	26.49	285	874	243	514
9.05	319	19.96	26.90	290	888	247	522

TABLE 3: MINIMUM CONDITIONED SPACE AREA & AIR-FLOW FOR R-32 REFRIGERANT

**NOTES: 1. Applies to fixed ducted systems with continuous air-flow or refrigerant detection systems
2. Based on LFL of 0.306 kg/m³**

DECOMMISSIONING AND DISPOSAL OF THE COIL

When the coil is at the end of its life and is being removed for replacement, proper procedures must be followed to assure the safety of the technician and building occupants due to the flammable refrigerant contained in the refrigeration system. Before conducting this procedure, it is essential that the technician is completely familiar with the equipment and all its detail. It is recommended good practice that all refrigerants are recovered safely. Prior to the task being conducted, an oil and refrigerant sample shall be taken in case analysis is required prior to re-use of recovered refrigerant. It is essential that electrical power is available before the task is commenced.

Decommissioning Procedure

- a. Become familiar with the equipment and its operation. Become familiar with the equipment and its operation.
- b. Before attempting the procedure, ensure that:
 - Mechanical handling equipment is available, if required, for handling refrigerant cylinders;
 - All personal protective equipment is available and being used correctly;
 - The recovery process is supervised at all times by a competent person;
 - Recovery equipment and cylinders conform to the appropriate standards.
- c. Pump down the refrigerant into the outdoor unit, if possible, by closing the outdoor unit liquid service valve and energizing the compressor until the suction pressure is near atmospheric pressure. If pumping the system down is not possible due to an inoperable compressor, the refrigerant must be recovered following local and national regulations.
- d. If a vacuum is not possible, make a manifold so that refrigerant can be removed from various parts of the system.
- e. Make sure that recovery cylinder is situated on the scales before recovery takes place.
- f. Start the recovery machine and operate in accordance with instructions. (**Also refer to Refrigerant Recovery Requirements** in the next column.)
- g. Do not overfill cylinders (no more than 80 % volume liquid charge).
- h. Do not exceed the maximum working pressure of the cylinder, even temporarily.
- i. When the cylinders have been filled correctly and the process completed, make sure that the cylinders and the equipment are removed from site promptly and all isolation valves on the equipment are closed off.
- j. Recovered refrigerant shall not be charged into another refrigerating system unless it has been cleaned and checked.
- k. Once all of the refrigerant has been pumped into the outdoor unit or has been recovered, disconnect the refrigerant lines from the coil. Continuously flush or purge with inert gas when using a flame to open the circuit at the field refrigerant line connections.

- l. Turn the circuit breaker(s) serving the furnace or air handler in the main electrical panel to the OFF position or if a disconnect switch has been installed near the furnace or air handler, switch it to the OFF position.
- m. Disconnect all electrical wiring from the coil.
- n. Once the refrigerant lines and electrical wiring have been disconnected from the , remove the coil from the property and dispose of it. Taking the coil to a recycling center is encouraged.
- o. Equipment shall be labeled stating that it has been decommissioned and emptied of refrigerant. The label shall be dated and signed. For appliances containing flammable refrigerants, ensure that there are labels on the equipment stating the equipment contains flammable refrigerant.

Refrigerant Recovery Requirements

When removing refrigerant from a system, either for servicing or decommissioning, it is recommended good practice that all refrigerants are removed safely.

When transferring refrigerant into cylinders, ensure that only appropriate refrigerant recovery cylinders are employed. Ensure that the correct number of cylinders for holding the total system charge is available. All cylinders to be used are designated for the recovered refrigerant and labeled for that refrigerant (i.e. special cylinders for the recovery of refrigerant). Cylinders shall be complete with pressure-relief valve and associated shut-off valves in good working order. Empty recovery cylinders are evacuated and, if possible, cooled before recovery occurs.

The recovery equipment shall be in good working order with a set of instructions concerning the equipment that is at hand and shall be suitable for the recovery of the flammable refrigerant. If in doubt, the manufacturer should be consulted. In addition, a set of calibrated weighing scales shall be available and in good working order. Hoses shall be complete with leak-free disconnect couplings and in good condition.

The recovered refrigerant shall be processed according to local legislation in the correct recovery cylinder, and the relevant waste transfer note arranged. Do not mix refrigerants in recovery units and especially not in cylinders. If compressors or compressor oils are to be removed, ensure that they have been evacuated to an acceptable level to make certain that flammable refrigerant does not remain within the lubricant. The compressor body shall not be heated by an open flame or other ignition sources to accelerate this process. When oil is drained from a system, it shall be conducted safely.

Disposal of the Coil

- Ensure sufficient ventilation at the working place.
- When flammable refrigerants are used,
 - evacuate the refrigerant circuit.
 - purge the refrigerant circuit with oxygen free nitrogen.