

INSTALLATION, MAINTENANCE, & DECOMMISSIONING MANUAL



Multi-Position, Upflow Only, and Horizontal Only DX and Chilled Water Coils

The following list includes important facts and information regarding the coils.

1. Coil size varies by model.
2. Coils are designed for A/C or heat pump operation.
3. Coils are designed for upflow, downflow, horizontal right, and horizontal left applications.

NOTE: The coil and its components are listed by ETL for the United States and Canada.

SAVE THIS MANUAL FOR FUTURE REFERENCE



⚠ WARNING

Improper installation may create a condition where the operation of the product could cause personal injury or property damage.

Improper installation, adjustment, alteration, service or maintenance can cause injury or property damage. Refer to this manual for assistance; or for additional information consult a qualified contractor, installer, or service agency.

⚠ WARNING

FIRE OR REFRIGERANT HIGH PRESSURE HAZARD

Failure to follow the safety warnings exactly could result in serious injury, death, or property damage.

A fire or refrigerant high pressure hazard may result causing property damage, personal injury or loss of life.

⚠ CAUTION

This product must be installed in strict compliance with the installation instructions and any applicable local, state, and national codes including, but not limited to building, electrical, and mechanical codes.

⚠ WARNING

RISK OF FIRE

This coil is equipped with a refrigerant leak detector for safety and with electrically powered safety measures. To be effective, the unit must be electrically powered at all times after installation, other than when servicing.

⚠ WARNING

RISK OF FIRE

This coil must be installed in a coil cabinet (case) for the refrigerant leak detection system to function properly.

⚠ WARNING

This coil shall only be connected to an outdoor unit suitable for the same refrigerant.

This coil (Model Series CA-0/CA-W) is a partial unit air conditioner, complying with partial unit requirements of Standard UL 60335-2-40 / CSA C22.2 No. 60335-2-40, and must only be connected to other units that have been confirmed as complying to corresponding partial unit requirements of Standard UL 60335-2-40 / CSA C22.2 No. 60335-2-40.



This is a safety alert symbol. When you see this symbol on labels or in manuals, be alert to the potential for personal injury.

Understand and pay particular attention to the signal words **DANGER, WARNING, or CAUTION.**

DANGER: Indicates an imminently hazardous situation, which if not avoided, **will result in death or serious injury.**

WARNING: Indicates a potentially hazardous situation, which if not avoided, **could result in death or serious injury.**

CAUTION: Indicates a potentially hazardous situation, which if not avoided, **may result in minor or moderate injury.** It is also used to alert against unsafe practices and hazards involving property damage.



WARNING

RISK OF FIRE

Do not use means to accelerate the defrosting process or to clean other than those recommended by the manufacturer.

The appliance shall be stored in a room without continuously operating ignition sources (e.g.: open flames, an operating gas appliance or an operating electric heater).

Do not pierce or burn. Be aware that refrigerants may not contain an odor.



WARNING

RISK OF FIRE

Refer to Table 2 or 3 for the minimum floor area of the conditioned space served by this coil due to the use of an A2L class flammable refrigerant.



IMPORTANT

The Clean Air Act of 1990 bans the intentional venting of refrigerant (CFC's and HFC's) as of July 1, 1992. Approved methods of reclaiming must be followed. Fines and/or incarceration may be levied for non-compliance.

Safety Requirements

1. This coil should be installed in accordance with all national and local building/safety codes and requirements, local plumbing and waste water codes, and other applicable codes. In the absence of local codes, install in accordance with the following codes.
 - Standard for the Installation of Air Conditioning and Ventilating Systems (NFPA 90A)
 - Standard for the Installation of Warm Air Heating and Air Conditioning Systems (NFPA 90B)
 - All local codes (State, City, and Township)

NOTE: All applicable codes take precedence over recommendations made in these instructions. Mortex Products, Inc. assumes no responsibility for coils that are installed in violation of any code or regulation.

2. Coil must be installed according to the above listed codes or the instructions in this manual.
3. These models are not UL listed or approved for installation into a Manufactured (Mobile) Home.
4. Failure to carefully read and follow all instructions in this manual can result in a malfunction that can lead to death, personal injury, and/or property damage.
5. Installing and servicing cooling or hot water coils can be hazardous due to high pressure, sub-zero refrigerant temperatures and/or hot water.
6. Only trained and qualified personnel should install, repair, or service heating/cooling coils. Untrained service personnel can perform basic maintenance functions such as cleaning of exterior surfaces and replacing the air filters. Observe all precautions in the manual and on the attached labels when servicing this coil.
7. These instructions cover minimum requirements and conform to existing national standards and safety codes. In some cases, these instructions exceed certain local codes and ordinances, especially those who have not kept up with changing home and/or HUD construction practices. These instructions are to be followed and are the minimum requirement for a safe installation.
8. Check that cabling will not be subject to wear, corrosion, excessive pressure, vibration, sharp edges or any other adverse environmental effects. The check shall also take into account the effects of aging or continual vibration from sources such as compressors or fans.
9. Installation, servicing and maintenance must only be performed by qualified service personnel that are licensed by the state to install, service, and repair HVAC equipment and those who have successfully completed a course in handling, installing, commissioning, maintenance, servicing, repairing, decommissioning, and disposing of equipment using a flammable refrigerant offered by an accredited national training organization or the manufacturer of the equipment.
10. This coil must not be operated with the access panel removed.
11. This coil is for use at elevations of 10,000 ft (3,048 m) or less.
12. This coil is not to be used by persons (including children) with reduced physical, sensory, or mental capabilities, or lack of experience and knowledge, unless they have been given supervision and instruction concerning use of this coil by a person responsible for their safety. Children must not be allowed to play with this coil.
13. The use of dropped ceilings for return air is not permitted for this coil.
14. Sealed electrical components must be replaced when they fail.
15. Intrinsically safe components must be replaced when they fail.
16. **Safely Commissioning of the System**
 - Ensure that the floor area is sufficient for the refrigerant charge or that the ventilation duct is assembled in a correct manner.
 - Connect the pipes and carry out a leak test before charging with refrigerant.
 - Check safety equipment before putting into service.

Proper Safe Working Procedures for Equipment Using Flammable Refrigerants

Prior to beginning work on systems containing flammable refrigerants, safety checks are necessary to ensure that the risk of ignition is minimized. For repair to the refrigerating system, the following steps must be completed prior to conducting work on the system.

1. Work shall be undertaken under a controlled procedure so as to minimize the risk of a flammable gas or vapor being present while the work is being performed.

2. All maintenance staff and others working in the local area shall be instructed on the nature of work being carried out. Work in confined spaces shall be avoided.
3. The area shall be checked with an appropriate refrigerant detector prior to and during work, to ensure the technician is aware of potentially toxic or flammable atmospheres. Ensure that the leak detection equipment being used is suitable for use with all applicable refrigerants, i.e. non-sparking, adequately sealed or intrinsically safe.
4. If any hot work is to be conducted on the refrigerating equipment or any associated parts, appropriate fire extinguishing equipment shall be available to hand. Have a dry powder or CO₂ fire extinguisher adjacent to the charging area.
5. No person performing work on a refrigerating system which involves exposing any pipe work shall use any sources of ignition in such a manner that it may lead to the risk of fire or explosion. All possible ignition sources, including cigarette smoking, should be kept sufficiently far away from the site of installation, repairing, removing and disposal, during which refrigerant can possibly be released to the surrounding space. Prior to work taking place, the area around the equipment is to be surveyed to make sure that there are no flammable hazards or ignition risks. "No Smoking" signs shall be displayed.
6. Ensure that the area is in the open or that it is adequately ventilated before breaking into the system or conducting any hot work. A degree of ventilation shall continue during the period that the work is carried out. The ventilation should safely disperse any released refrigerant and preferably expel it externally into the atmosphere.
7. Where electrical components are being changed, they shall be fit for the purpose and to the correct specification. At all times, the manufacturer's maintenance and service guidelines shall be followed. If in doubt, consult the manufacturer's technical department for assistance.
8. The following checks shall be applied to installations using flammable refrigerants:
 - The actual refrigerant charge is in accordance with the room size within which the refrigerant containing parts are installed;
 - Marking to the equipment continues to be visible and legible. Markings and signs that are illegible shall be corrected;
 - Refrigerating pipe or components are installed in a position where they are unlikely to be exposed to any substance which may corrode refrigerant containing components, unless the components are constructed of materials which are inherently resistant to being corroded or are suitably protected against being so corroded.

9. Detection of Flammable Refrigerants

Under no circumstances shall potential sources of ignition be used in the searching for or detection of refrigerant leaks. A halide torch (or any other detector using a naked flame) shall not be used.

The following leak detection methods are deemed acceptable for all refrigerant systems.

Electronic leak detectors may be used to detect refrigerant leaks but, in the case of flammable refrigerants, the sensitivity may not be adequate, or may need re-calibration. (Detection equipment shall be calibrated in a refrigerant-free area.) Ensure that the detector is not a potential source of ignition and is suitable for the refrigerant used. Leak detection equipment shall be set at a percentage of the LFL of the refrigerant and shall be calibrated to the refrigerant employed, and the appropriate percentage of gas (25 % maximum) is confirmed.

Leak detection fluids are also suitable for use with most refrigerants, but the use of detergents containing chlorine shall be avoided as the chlorine may react with the refrigerant and corrode the copper pipe-work.

NOTE: Examples of leak detection fluids are:

- bubble method,
- fluorescent method agents.

If a leak is suspected, all naked flames shall be removed/ extinguished.

If a leakage of refrigerant is found which requires brazing, all of the refrigerant shall be recovered from the system, or isolated (by means of shut off valves) in a part of the system remote from the leak. Removal of refrigerant shall be according to Step 10 below.

10. Removal and Evacuation

When breaking into the refrigerant circuit to make repairs or for any other purpose, conventional procedures shall be used. However, for flammable refrigerants, it is important that best practice be followed since flammability is a consideration. The following procedure shall be adhered to:

- safely remove refrigerant following local and national regulations;
- evacuate;
- purge the circuit with inert gas (optional for A2L);
- evacuate (optional for A2L);
- continuously flush or purge with inert gas when using flame to open circuit; and
- open the circuit.

The refrigerant charge shall be recovered into the correct recovery cylinders if venting is not allowed by local and national codes. For appliances containing flammable refrigerants, the system shall be purged with oxygen-free nitrogen to render the appliance safe for flammable refrigerants. This process might need to be repeated several times. Compressed air or oxygen shall not be used for purging refrigerant systems.

For appliances containing flammable refrigerants, purging shall be achieved by breaking the vacuum in the system with oxygen-free nitrogen and continuing to fill until the working pressure is achieved, then venting to atmosphere, and finally pulling down to a vacuum (optional for A2L). This process shall be repeated until no refrigerant is within the system (optional for A2L). When the final oxygen-free nitrogen charge is used, the system shall be vented down to atmospheric pressure to enable work to take place.

The outlet for the vacuum pump shall not be close to any potential ignition sources, and ventilation shall be available.

11. Charging Procedures

In addition to conventional charging procedures, the following requirements shall be followed.

- Ensure that contamination of different refrigerants does not occur when using charging equipment. Hoses or lines shall be as short as possible to minimize the amount of refrigerant contained in them.
- Cylinders shall be kept in an appropriate position according to the instructions.
- Ensure that the refrigerating system is earthed prior to charging the system with refrigerant.
- Label the system when charging is complete (if not already).
- Extreme care shall be taken not to overfill the refrigerating system.

Prior to recharging the system, it shall be pressure-tested with the appropriate purging gas. The system shall be leak-tested on completion of charging but prior to commissioning. A follow up leak test shall be carried out prior to leaving the site.

12. Refrigerant Recovery Requirements

When removing refrigerant from a system, either for servicing or decommissioning, it is recommended good practice that all refrigerants are removed safely.

When transferring refrigerant into cylinders, ensure that only appropriate refrigerant recovery cylinders are employed. Ensure that the correct number of cylinders for holding the total system charge is available. All cylinders to be used are designated for the recovered refrigerant and labeled for that refrigerant (i.e.: special cylinders for the recovery of refrigerant). Cylinders shall be complete with pressure-relief valve and associated shut-off valves in good working order. Empty recovery cylinders are evacuated and, if possible, cooled before recovery occurs.

The recovery equipment shall be in good working order with a set of instructions concerning the equipment that is at hand and shall be suitable for the recovery of the flammable refrigerant. If in doubt, the manufacturer should be consulted. In addition, a set of calibrated weighing scales shall be available and in good working order. Hoses shall be complete with leak-free disconnect couplings and in good condition.

The recovered refrigerant shall be processed according to local legislation in the correct recovery cylinder, and the relevant waste transfer note arranged. Do not mix refrigerants in recovery units and especially not in cylinders.

If compressors or compressor oils are to be removed, ensure that they have been evacuated to an acceptable level to make certain that flammable refrigerant does not remain within the lubricant. The compressor body shall not be heated by an open flame or other ignition sources to accelerate this process. When oil is drained from a system, it shall be carried out safely.

13. Commissioning of the System

- Ensure that the floor area is sufficient for the refrigerant charge or that the ventilation duct is assembled in a correct manner.
- Connect the pipes and perform a leak test before charging with refrigerant.
- Check safety equipment before putting into service.

14. Maintenance of the Coil

- Ensure sufficient ventilation at the repair place.
- Be aware that malfunction of the equipment may be caused by refrigerant loss and a refrigerant leak is possible.
- Discharge capacitors in a way that won't cause any spark. The standard procedure to short circuit the capacitor terminals usually creates sparks.
- Reassemble sealed enclosures accurately. If seals are worn, replace them.
- Check safety equipment before putting the system into service.

15. Repair of the Coil

- Ensure sufficient ventilation at the repair place.
- Be aware that malfunction of the equipment may be caused by refrigerant loss and a refrigerant leak is possible.
- Discharge capacitors in a way that won't cause any spark.
- When brazing is required, the following procedures shall be performed in the following order:

- Safely remove the refrigerant following local and national regulations. If the recovery is not required by national regulations, drain the refrigerant to the outside. Take care that the drained refrigerant will not cause any danger. In doubt, one person should guard the outlet. Take special care that drained refrigerant will not float back into the building;
- Purge the refrigerant circuit with oxygen free nitrogen;
- Evacuate the refrigerant circuit;
- Remove parts to be replaced by cutting or brazing.
- Purge the braze point with nitrogen during the brazing procedure required for repair.
- Perform a leak test before charging with refrigerant.
- Reassemble sealed enclosures accurately. If seals are worn, replace them.
- Check safety equipment before putting the system back into service.

16. Decommissioning of the Coil (Refer to the last page of this manual for additional information)

- If the safety is affected when the equipment is put out of service, the refrigerant charge shall be removed before decommissioning.
- Ensure sufficient ventilation at the equipment location.
- Be aware that malfunction of the equipment may be caused by refrigerant loss and a refrigerant leak is possible.
- Remove the refrigerant. If the recovery is not required by national regulations, drain the refrigerant to the outside. Take care that the drained refrigerant will not cause any danger. In doubt, one person should guard the outlet. Take special care that drained refrigerant will not float back into the building.

17. Disposal of the Coil (Refer to the last page of this manual for additional information)

- Ensure sufficient ventilation at the working place.
- Remove the refrigerant. If the recovery is not required by national regulations, drain the refrigerant to the outside. Take care that the drained refrigerant will not cause any danger. In doubt, one person should guard the outlet. Take special care that drained refrigerant will not float back into the building.
- When flammable refrigerants are used,
 - evacuate the refrigerant circuit.
 - purge the refrigerant circuit with oxygen free nitrogen.

WARNING

RISK OF FIRE – FLAMMABLE REFRIGERANT APPLICATIONS

If any refrigerating circuit contains more than 62.6 oz (1.776 kg) of R-454B refrigerant or more than 64.6 oz (1.836 kg) of R-32 refrigerant, an unventilated area where a coil using a flammable refrigerant is installed shall be so constructed that should any refrigerant leak, it will not stagnate and create a fire or explosion hazard.

WARNING

FIRE HAZARD

For coils using A2L are not connected via an air duct system to one or more rooms, auxiliary devices which may be a potential ignition source shall not be installed in the duct work. Examples of such potential ignition sources are hot surfaces with a temperature exceeding 1290°F (700°C) and electric switching devices.

For coils using A2L refrigerants connected via an air duct system to one or more rooms, only auxiliary devices approved by the coil manufacturer or declared suitable with the refrigerant shall be installed in connecting ductwork.

WARNING

FIRE HAZARD

For coils using A2L refrigerants connected via an air duct system to one or more rooms with a floor area less than shown in Table 2 or 3, those rooms shall be without continuously operating open flames (e.g.: an operating gas appliance) or other potential ignition sources (e.g.: an operating electric heater, hot surfaces). A flame producing device may be installed in the same space if the device is provided with an effective flame arrest.

INSPECTION

As soon as the coil is received, it should be inspected for possible shipping damage. If damage is evident, the extent of the damage should be noted on the carrier's freight bill. A separate request for inspection by the carrier's agent should be made in writing. Before installing the coil, check the cabinet for screws which may have loosened during transit. There are no shipping or spacer brackets requiring removal before installation.

See local Distributor for more information. Mortex Products, Inc assumes no liability for freight damage.

GENERAL INFORMATION

1. The blower and duct system must be properly sized to provide adequate cooling and heating performance.
2. Select the correct furnace or air handler blower motor speed tap to achieve the required CFM needed for cooling capacity.
3. Return air filters of generous size must be provided in order to avoid contaminating the coil, blower and ductwork.
4. It is essential that the indoor coil and outdoor unit be properly matched and the correct TXV is installed. A TXV or flowrator piston that is too small will cause refrigerant starving and high suction superheat and one that is too large will cause unstable refrigerant pressures and suction superheat.
5. For applications that utilize a flowrator piston instead of a TXV, it is essential that the correct piston size is installed. A flowrator piston that is too small will cause refrigerant starving and one that is too large will cause insufficient superheat and potential compressor failure.

NOTE: Improper sizing of TXV, flowrator piston, or incorrect charge will result in inefficient operation and possible compressor failure.

6. Provide adequate clearances for service access to the coil.
7. The size of the coil should be based on an acceptable heat loss and heat gain calculation for the structure. ACCA Manual J or other approved methods may be used.

Maximum Operating Temperature for Heat Pump Applications

For heat pump applications, the maximum outdoor temperature recommended by the manufacturer while the system is operating in the heating mode is 75.0°F/23.9°C.

COIL SELECTION

Summit indoor coils are designed for use with most residential gas furnaces, electric furnaces, and Summit air handlers in upflow, downflow, or horizontal applications.

These instructions are intended to assist qualified service personnel trained and experienced in the proper installation of this type of equipment. Some state codes require installation and service personnel to be licensed. Refer to authorities having jurisdiction for additional guidance.

Efficiency and capacity ratings are listed in the current AHRI Directory for Summit coils matched with many brands of outdoor condensing units or heat pumps. Air-conditioning coil matches are listed in the indoor coil manufacturer's air-conditioning section. Heat pump coil matches are listed in the indoor coil manufacturer's heat pump section. Where ratings require addition of an expansion valve (TXV), kits are available that can be added to a Summit coil in the field without cutting or brazing. See the instructions for converting a coil from a flowrator to a TXV.

SELECTING THE CORRECT SUMMIT HEAT PUMP COIL FOR A SPECIFIC HEAT PUMP OUTDOOR UNIT

The selection of an indoor heat pump coil is much more critical than the selection of a straight air-conditioning coil. The differences for heat pump coils are as follows:

- Only indoor coils with a flowrator distributor or a TXV with an internal check valve may be used in heat pump applications. These devices permit reverse refrigerant flow though the device when the system is operating in the heating mode.
- Matching of indoor coils for heat pumps requires the capacity and internal volume to be equivalent to that of the smallest internal volume OEM matched coil recommended by outdoor unit manufacturer of that particular outdoor unit.
- The selection must be based a matched AHRI certified for a specific coil with a specific orifice or TXV and a specific make and model number of outdoor heat pump unit.
- Choosing a matched combination of a Summit indoor heat pump coil and specific outdoor heat pump models as certified in the Summit heat pump section of the current AHRI Directory will assure proper and efficient operation of a heat pump system.
- Failure to select and install an AHRI certified matched combination will affect efficiency, charging, and reliability and may result in premature failure of the system.

IMPORTANT INSTRUCTIONS FOR PREPARING "M" SERIES MULTI-POSITION COILS FOR INSTALLATION

- Multi-position coils are provided with a supply duct flange that can be attached to either end of the coil case as necessary depending on the orientation of the coil. Air may blow into either the apex or the open end of the "A" coil.
- Multi-position coils are shipped with the horizontal drainpan positioned for applications where the apex of the coil is pointing to the left when viewing the coil from the front. For those

applications, the coil top cap must be removed, repositioned, and re-caulked as shown in Figure 2.

- For applications where the apex of the coil points to the right when viewing the coil from the front, the horizontal drain pan must be removed and re-installed on the bottom of the coil and the coil top cap must be removed, repositioned, and re-caulked as shown in Figure 2.
- Horizontal right discharge applications using 17.5" wide and larger coils also require the refrigerant leak sensor to be relocated to the other side of the coil's front delta plate as described in the **REFRIGERANT LEAK DETECTION SYSTEM** section that begins on page 14.
- For horizontal reverse air-flow applications where the air enters the apex of the coil, caulking must be used to seal between the vertical and horizontal drain pans to prevent air from blowing water out of the horizontal drain pan between the drain pans as shown in Figure 2. Seal the seam between the vertical and horizontal drain pans by caulking the mating surface on the horizontal drain pan and setting the vertical drain pan on it. Center the vertical drain pan in horizontal drain pan and add screws in the corners to secure the drain pans together.
- On some multi-position coils where the air enters the open end of the "A" coil and the apex of the coil is downstream from the air inlet, a condensate blow-off guard is provided for horizontal applications and must be attached to the horizontal drain pan to catch any condensate blow off (See Figure 4)

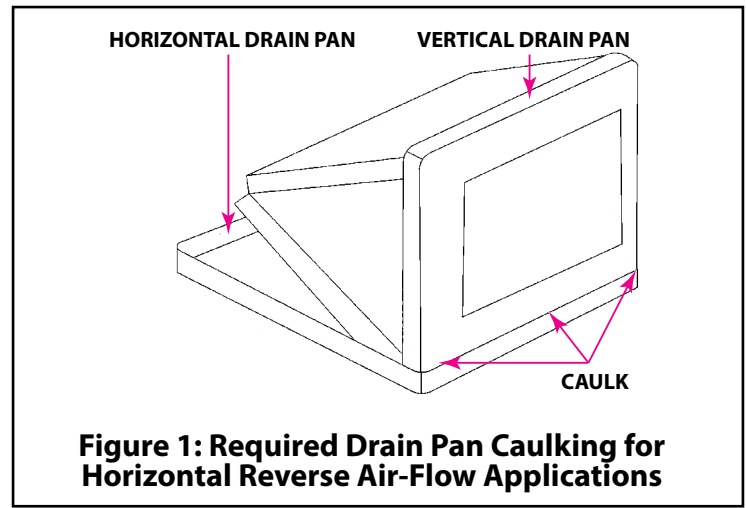

IMPORTANT

All horizontal applications require baffles to be attached to the front and back of the coil apex as shown in Figure 3. These baffles are required for the refrigerant leak detection system to function properly should a refrigerant leak develop when the coil is operating in the horizontal orientation. For cased coils, the coil must be removed from the case before installing the baffles. For horizontal right discharge applications, reposition and caulk the top cap (See Figure 2) and horizontal drain pan (See Figure 1) before installing the baffles. Remove the baffles from the parts bag provided with the coil. The narrower baffle is to be installed at the back of the coil and the wider baffle is to be installed at the front of the coil where the header and TXV are located. Place the baffles on top of the coil apex as shown in Figure 3 and use the 2 screws provided in the parts bag to attach each baffle tab to the top of the coil delta plates as shown in Figure 3. Slide the coil into the coil case and continue with the coil installation process.

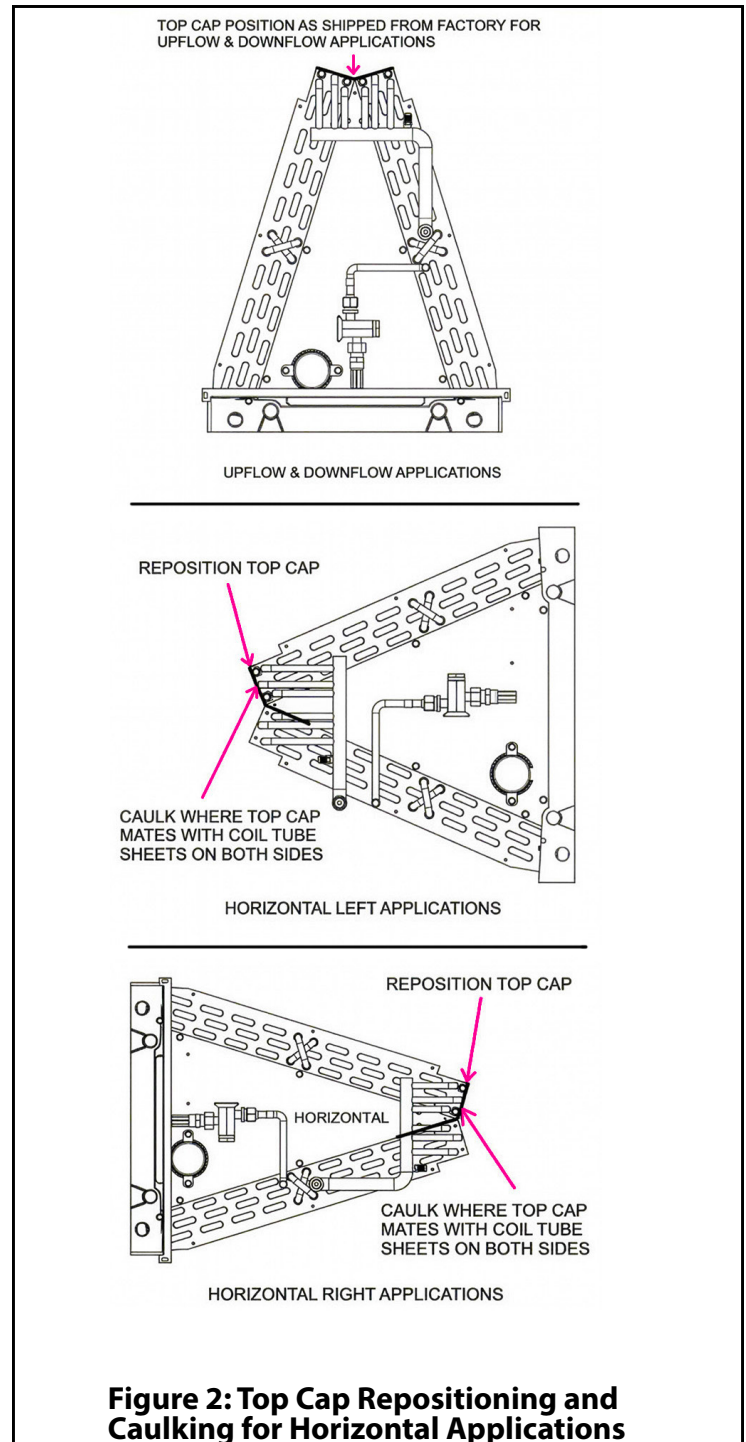

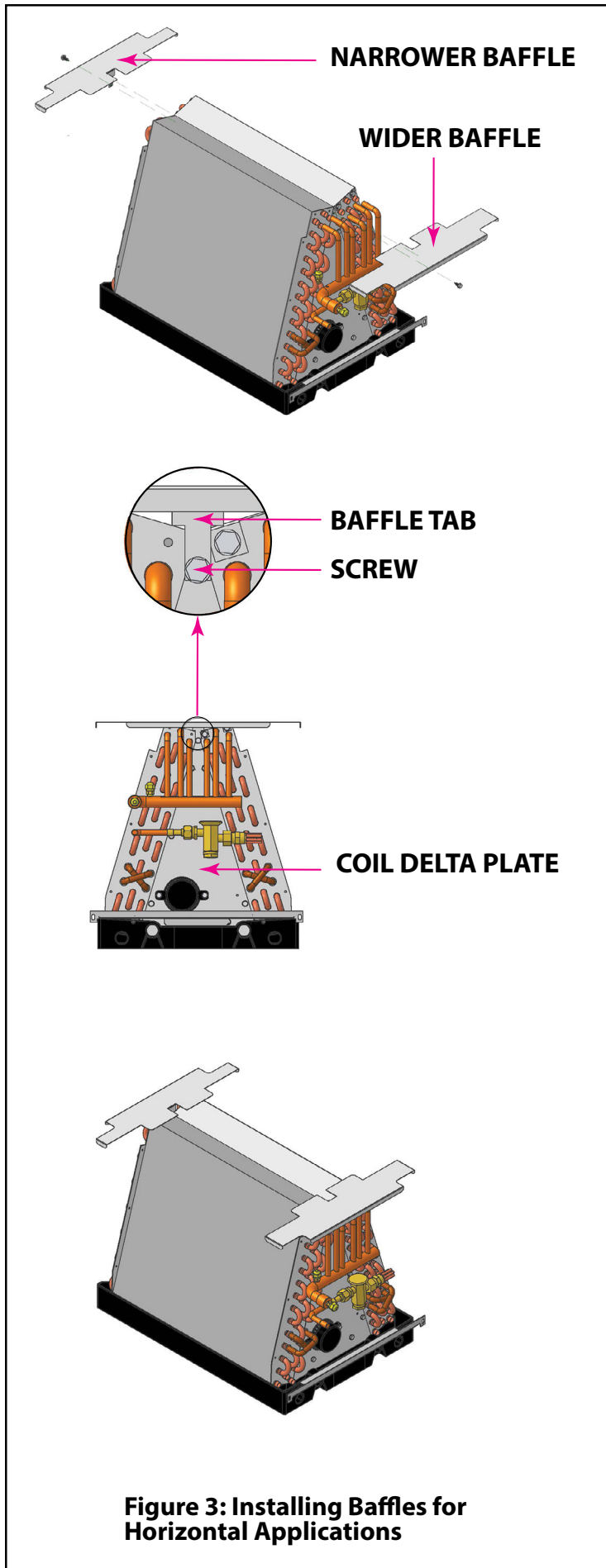

Figure 3: Installing Baffles for Horizontal Applications

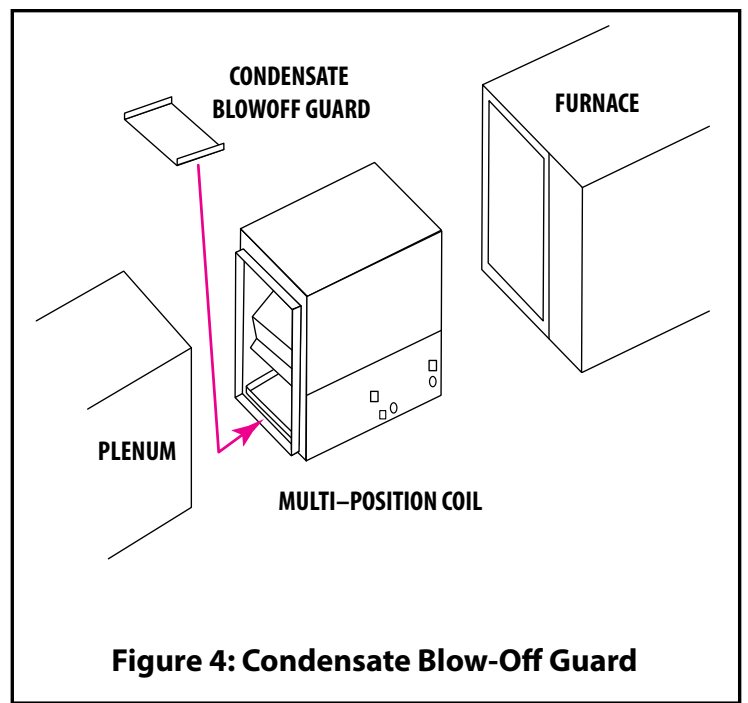

Figure 4: Condensate Blow-Off Guard

Minimum Conditioned Space for Flammable A2L Refrigerants. When flammable A2L class refrigerants are used, the minimum floor area of the conditioned space the coil serves must comply with Table 2 or 3 to allow a refrigerant leak to disperse and be diluted with air to eliminate the risk of the refrigerant igniting and causing an explosion and/or fire. The minimum floor area must be corrected by an altitude adjustment factor based on the building site ground level altitude. See Table 1 for the altitude adjustment factor for various altitudes and refer to the example below for how to apply the altitude adjustment factor.

Example:

Total System Charge = 2.6 kg of R-454B

Altitude = 2400 m

Min. Conditioned Floor Area (MCFA) from Table 2 = 7.97 m²

Altitude Adjustment Factor (AF) from Table 1 = 1.24

Adjusted MCFA = MCFA x AF

Adjusted MCFA (@ 2400 m. altitude) = 7.97 m² x 1.24 = 9.88 m²

Altitude Correction Factors									
Altitude (m)	0	100	200	300	400	500	600	700	800
Altitude (ft)	0	328	656	984	1312	1640	1969	2297	2625
AF	1.00	1.01	1.02	1.02	1.03	1.04	1.05	1.06	1.07
Altitude (m)	900	1000	1100	1200	1300	1400	1500	1600	1700
Altitude (ft)	2953	3281	3609	3937	4265	4593	4921	5249	5577
AF	1.08	1.09	1.10	1.11	1.12	1.13	1.14	1.15	1.16
Altitude (m)	1800	1900	2000	2100	2200	2300	2400	2500	2600
Altitude (ft)	5906	6234	6562	6890	7218	7546	7874	8202	8530
AF	1.17	1.18	1.19	1.20	1.21	1.22	1.24	1.25	1.26
Altitude (m)	2700	2800	2900	3000	3100	3200	3400	3600	3700
Altitude (ft)	8858	9186	9514	9842	10171	10499	11155	11811	12139
AF	1.27	1.29	1.30	1.31	1.33	1.34	1.37	1.40	1.42

Table 1: Altitude Adjustment Factors

COIL INSTALLATION

The coil must be installed level or sloped slightly toward the condensate drain fittings. Run the primary and secondary (higher fitting) drain lines to an open drain and never to a closed sewer. Slope the drain lines downward away from drain pan to assure proper drainage of the condensate. Always test drain lines with water before operating. Reducing the size of the condensate drain lines is not recommended.

Cased coils are designed to eliminate the need for a transition between the coil and furnace in most applications. In blow-through applications, the furnace air discharge opening and coil case air inlet must allow uniform air distribution across the coil surface. If this cannot be achieved with a direct connection, a minimum of 18" length field supplied transition must be installed between the furnace and coil case air inlet.

When the coil is installed on a gas furnace, use a non-tape sealant such as mastic or an aerosol sealant to seal the supply duct to the coil case and to seal between the coil case and furnace to prevent air leakage.

It is recommended that the coil fins be sprayed with a coil cleaning solution and rinsed thoroughly before installation to assure proper drainage of condensate from the coil fins, to eliminate the possibility of water blow off, and to assure maximum coil performance. If the coil fins are not sprayed with a coil cleaning solution, approximately 50 hours of break-in time is required to achieve the same results.

NOTE: Utilizing the space above a dropped ceiling for return air is not permissible for this coil.

WARNING

RISK OF FIRE – FLAMMABLE REFRIGERANT APPLICATIONS

If any refrigerating circuit contains more than 62.6 oz (1.776 kg) of R-454B refrigerant or more than 64.6 oz (1.836 kg) of R-32 refrigerant, an unventilated area where a coil using a flammable refrigerant is installed shall be so constructed that should any refrigerant leak, it will not stagnate and create a fire or explosion hazard.

If the air duct system connected to one or more rooms with an area less than the minimum conditioned space floor area shown in Table 2 or 3 based on the total system refrigerant charge, that room shall be without continuously operating open flames (e.g.: an operating gas appliance) or other potential ignition sources (e.g.: an operating electric heater, hot surfaces). A flame-producing device may be installed in the same space if the device is provided with an effective flame arrest

WARNING

RISK OF FIRE – FLAMMABLE REFRIGERANT APPLICATIONS

The following requirements are necessary to allow the flammable refrigerant mitigation system to properly dilute the refrigerant with air in the event of a refrigerant leak.

The supply and return air shall be directly ducted to the space. Open areas such as false ceilings shall not be used as a return air duct.

WARNING

RISK OF FIRE

Refer to Table 2 or 3 for the minimum floor area of the conditioned space served by this coil due to the use of an A2L class flammable refrigerant.

WARNING

RISK OF FIRE – FLAMMABLE REFRIGERANT APPLICATIONS

The ductwork connected to this coil shall not contain an ignition source.

Auxiliary devices which may be a potential ignition source shall not be installed in the duct work. Examples of such potential ignition sources are hot surfaces with a temperature exceeding 1292°F (700°C) and electric switching devices.

Only auxiliary devices approved by the coil manufacturer or declared suitable with the refrigerant shall be installed within connecting ductwork.

REFRIGERANT LINE PIPING

DX coils require the liquid and suction lines to be sized in accordance with outdoor unit manufacturer's instructions.

Most Summit coils are equipped with a Schrader port on the suction header to allow field installation of the thermal expansion valve equalizer line without the use of a torch. The Schrader valve also serves the purpose of verifying the coil is leak-free prior to installation using the following procedure:

Checking Coil For Leaks Prior to Installation Using Schrader Valve: Unscrew the Schrader valve cap and press the depressor. If there is no release of pressure when the Schrader valve is depressed, the coil may have developed a leak during shipment and should be returned to the point of purchase for exchange.

If pressure is present when the Schrader valve is depressed, completely relieve the pressure in the coil by continuing to depress the Schrader valve. When all of the pressure has been released, cut the ends of the copper suction and liquid line stubs off with a tubing cutter.

For a coil without a Schrader port, relieve pressure by punching a hole with a pointed instrument in the end of the suction line (large copper) stub before cutting the ends off.

NOTE: If there is no release of pressure when the suction stub is punctured, the coil may have developed a leak during shipment and should be returned to the point of purchase for exchange.

Refrigerant lines should be soldered with silver solder or high temperature brazing alloy. Check all field installed refrigerant connections with an electronic leak detector, halide torch, or soap bubbles. The suction line must be insulated to avoid condensate from forming and dripping off. Armaflex (or equivalent) with 3/8" (1 cm) minimum wall thickness is recommended. Suction line insulation in hot and/or humid applications should have 1/2" (1.3 cm) minimum wall thickness.

Refrigerant line piping is critical when the outdoor unit is to be located below the level of the coil to ensure proper oil return to the compressor in the outdoor unit. For proper piping design considerations, refer to the refrigerant line guidelines furnished by the manufacturer of the outdoor unit. If outdoor unit is installed above the indoor coil, oil traps are required at equal intervals along suction line (See Figure 5). Horizontal suction lines should slope downward 1 inch for every 20 feet toward outdoor unit. Dry nitrogen must be flowed through refrigerant lines during soldering operation to prevent copper oxide from forming inside the tubing which can plug TXV inlet screens and filter driers.

Refer to the installation instructions provided with the outdoor unit, furnace, air handler, and line sets for completion of refrigerant line piping and system installation.

SPECIAL PIPING INSTRUCTIONS DUE TO THE USE OF AN A2L CLASS FLAMMABLE REFRIGERANT

WARNING

RISK OF FIRE

This following precautions must be taken for the refrigerant piping due to this coil being used with an A2L class flammable refrigerant.

Piping material, pipe routing, and installation shall include protection from physical damage in operation and service, and shall be in compliance with national and local codes and standards, such as ASHRAE 15, IAPMO Uniform Mechanical Code, ICC International Mechanical Code, or CSA B52. All field joints shall be accessible for inspection prior to being covered or enclosed.

The installation of pipe-work shall be kept to a minimum.

Due to this coil being used with an A2L class flammable refrigerant, the refrigerant pipe-work shall not be installed in an unventilated space if that space is smaller than the minimum floor area shown in Table 2 or 3 unless there are no joints in the pipe-work in that space (e.g.: pipework that is run in walls or between floors).

Since refrigerant line length affects the final refrigerant charge, the final refrigerant charge after field charging of the system must be noted and used when determining the minimum floor area of the conditioned space from Table 2 or 3.

Mechanical connections shall be accessible for maintenance purposes.

For appliances using flammable refrigerants, all joints made in the installation between parts of the refrigerating system, with at least one part charged, shall be made in accordance with the following:

- A brazed, welded, or mechanical connection shall be made before opening the valves to permit refrigerant to flow between the refrigerating system parts. A vacuum valve shall be provided to evacuate the interconnecting pipe or any uncharged refrigerating part.
- Mechanical connectors used indoors shall comply with ISO 14903 or UL 207 Annex A (USA only). When mechanical connectors are reused indoors, sealing parts shall be renewed. When flared joints are reused indoors, the flare part shall be refabricated.
- Refrigerant tubing shall be protected or enclosed to avoid damage.
- Flexible refrigerant connectors (such as connecting lines between the indoor and outdoor unit) that may be displaced during normal operation shall be protected against mechanical damage.

For installations with field applied joints that are exposed in the occupied space, these joints shall be at least one of the following:

- Mechanical joints in compliance with ISO 14903 or UL 207 (USA only)
- Welded or brazed joints; or
- Joints in enclosures that vent to the unit or to the outside.

Provision shall be made for expansion and contraction of long runs of piping.

Protection devices, piping, and fittings shall be protected as far

- Install 1 oil trap for a height difference of 15 ft to 25 ft (4.6 m to 7.6 m) between indoor and outdoor units.
- Install 2 oil trap for a height difference of 26 ft to 50 ft (7.9 m to 15.2 m) between indoor and outdoor units.
- Install 3 oil trap for a height difference of 51 ft to 100 ft (15.5 m to 30.5 m) between indoor and outdoor units.
- Install 4 oil trap for a height difference of 101 ft to 150 ft (30.8 m to 45.7 m) between indoor and outdoor units.

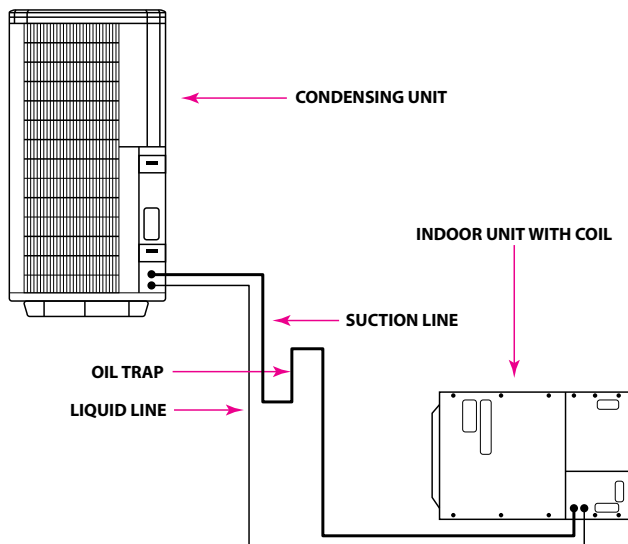

Figure 5: Refrigerant Lines For Coil Below Outdoor Unit

as possible against adverse environmental effects, for example, the danger of water collecting and freezing in relief pipes or the accumulation of dirt and debris.

Piping in refrigeration systems shall be so designed and installed to minimize the likelihood of hydraulic shock damaging the system.

After completion of field piping for split systems, the field pipework shall be pressure tested with an inert gas and then vacuum tested prior to refrigerant charging, according to the following requirements:

- The minimum test pressure for the low side of the system shall be the low side design pressure as stated on the coil rating plate and the minimum test pressure for the high side of the system shall be the high side design pressure as stated on the coil rating plate, unless the high side of the system cannot be isolated from the low side of the system in which case the entire system shall be pressure tested to the low side design pressure.
- The test pressure after removal of pressure source shall be maintained for at least 1 hour with no decrease of pressure indicated by the test gauge, with test gauge resolution not exceeding 5% of the test pressure.
- During the evacuation test, after achieving a vacuum level specified in the manual or less, the refrigeration system shall be isolated from the vacuum pump and the pressure shall not rise above 1500 microns within 10 min. The vacuum pressure level shall be the lesser of 500 microns or the value required for compliance with national and local codes and standards, which may vary between residential, commercial, and industrial buildings.

Field-made refrigerant joints indoors shall be tightness tested. The test method shall have a sensitivity of 5 grams per year of refrigerant or better under a pressure of at least 0.25 times the maximum allowable pressure. No leak shall be detected.

CONDENSATE DRAIN PIPING:

A condensate trap is recommended for all coil applications, but is required for air handler applications and any other application where the coil is subjected to negative pressure in a draw-through configuration.

The coil drain pan has two 3/4" NPT female primary and two secondary connections (left and right side). The horizontal drain pan has two 3/4" NPT female, one primary and one secondary. Piping from each fitting is to have a 2" minimum trap (See Figure 6) and must be sloped enough for adequate drainage to a visible area. Do not pipe the primary and secondary drains fittings together into a common line. Cap all unused condensate connections.

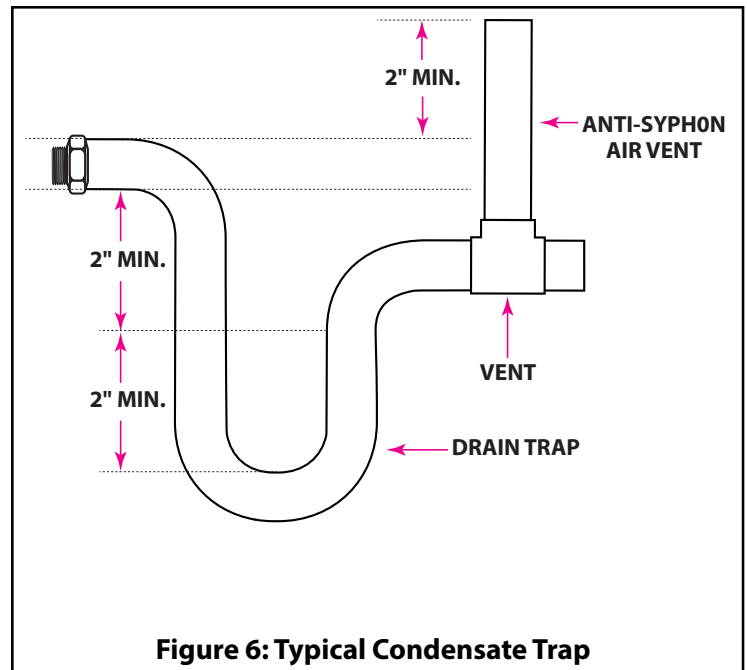

Figure 6: Typical Condensate Trap

⚠ CAUTION

An auxiliary drain pan is required for any coil or air handler installed in an attic or above a finished ceiling.

The auxiliary drain pan must have its own drain line (no water trap is necessary) with its output into an open drain (not closed sewer).

The auxiliary drain pan and its drain line outlet should allow easy visual inspection to allow the homeowner /user to see that the coil condensate drain lines are plugged and require maintenance.

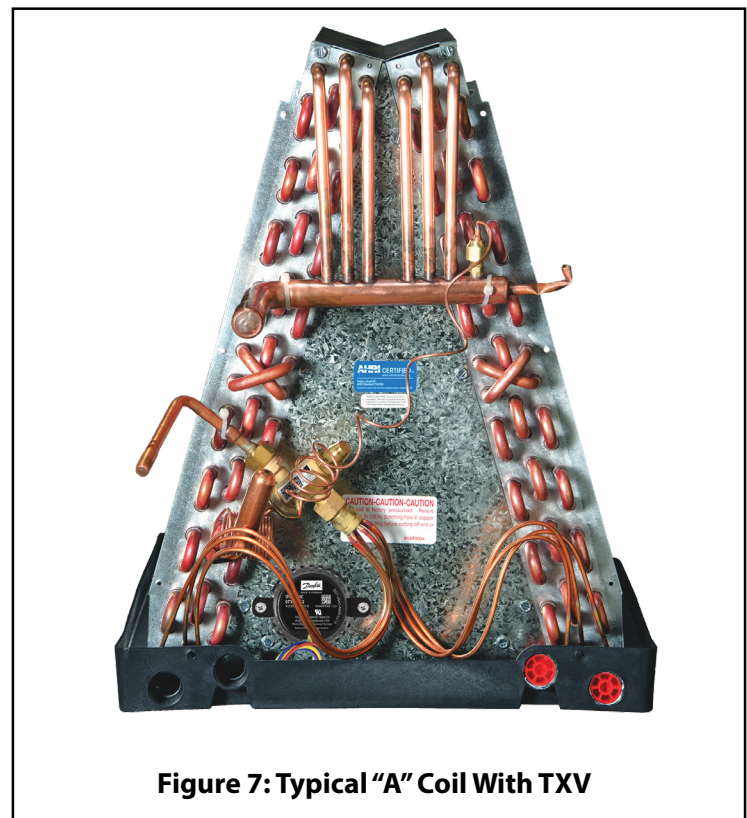

Figure 7: Typical "A" Coil With TXV

⚠ WARNING

Failure to install a trap in coil applications and any other applications where the coil is subjected to a negative pressure can result in improper drainage and a potential shock hazard.

THERMAL EXPANSION VALVE (TXV)

A thermal expansion valve (TXV) is designed to regulate the rate at which refrigerant flows into the indoor coil and to maintain the proper suction superheat. The TXV must be the proper size and type for the applications to achieve the performance ratings of the system. The TXV used in Summit coils and field installed TXV kits has a built-in check valve required for heat pump applications. The TXV's external equalizer line has a female flare nut with built in Schrader valve depressor that attaches to the Schrader valve port located on the indoor coil suction manifold. The TXV also has a sensing bulb used to sense the temperature the suction line that must be attached to the suction line (large refrigerant line) after the refrigerant tubing has been installed.

The sensing bulb must be securely attached to the suction line using the two furnished bulb clamps. The ideal location for the TXV sensing bulb is on a horizontal section of the suction line tube outside the coil case and positioned between 10 o'clock and 2 o'clock on the tube (See Figures 7 and 8).

NOTE: Improper sizing of TXV, flowrator piston, or incorrect charge will result in inefficient operation and possible compressor failure.

If the sensing bulb must be installed on a vertical section of the suction line, the bulb should be located at least 6 inches away from any bend and on the side of the tube that is above the inside of the bend. On vertical run bulb installations, the bulb should be positioned with the bulb capillary tube at the top.

The sensing bulb must be able to sense the temperature of the superheated suction vapor and must therefore not be located in a position that will expose it to extraneous heat/cold. The sensing bulb must therefore be insulated to isolate it from the surrounding air using the furnished insulation tape.

NOTE: If a non-bleed type TXV is used, the outdoor unit may require a hard start kit to allow the compressor to start under load.

FLOWRATOR TO TXV CONVERSION:

While thermal expansion valves can be factory installed, they are normally available in kit form for field installation without the need for cutting or brazing. Follow the installation instructions provided with the TXV kit. A TXV kit should be field installed before the system is charged.

NOTE: Make sure the flowrator piston has been removed from the flowrator distributor body prior to installing a TXV kit.

FIELD INSTALLED TXV KIT INFORMATION

R72DB0101DF: R-32, 1.5 – 3.0 Ton, 15% Bleed,
Inlet: Male Rotolock, Outlet: Female Swivel Nut

R72DB0102DF: R-32, 3.0 – 5.0 Ton, 15% Bleed,
Inlet: Male Rotolock, Outlet: Female Swivel Nut

R72DB0103DF: R-454B, 1.5 – 3.0 Ton, 15% Bleed,
Inlet: Male Rotolock, Outlet: Female Swivel Nut

R72DB0104DF: R-454B, 3.0 – 5.0 Ton, 15% Bleed,
Inlet: Male Rotolock, Outlet: Female Swivel Nut

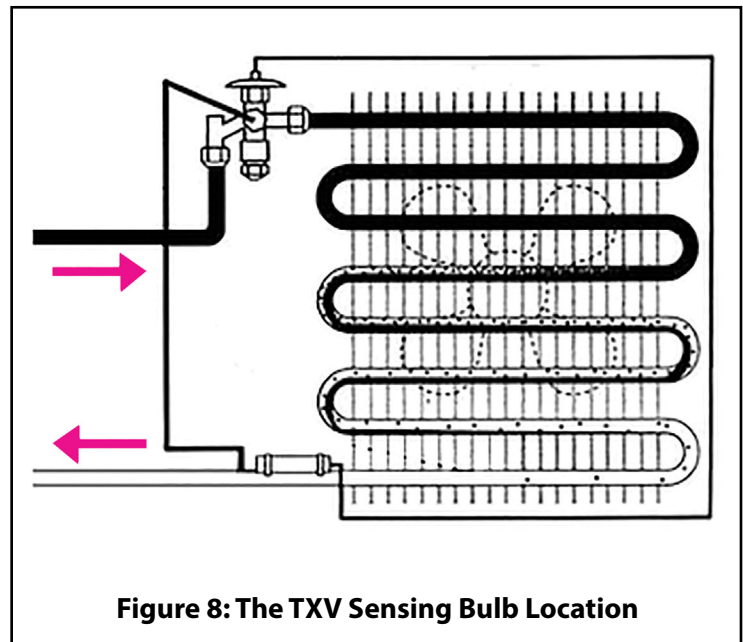

Figure 8: The TXV Sensing Bulb Location

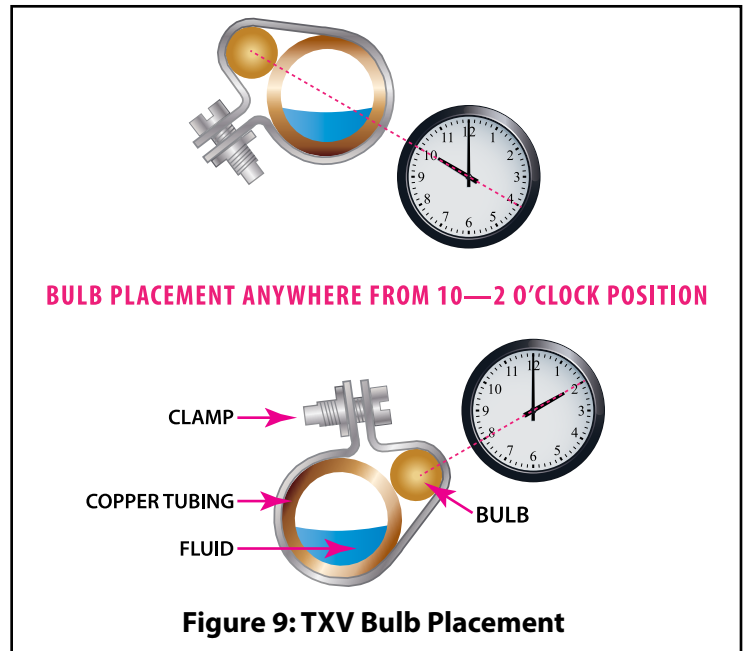
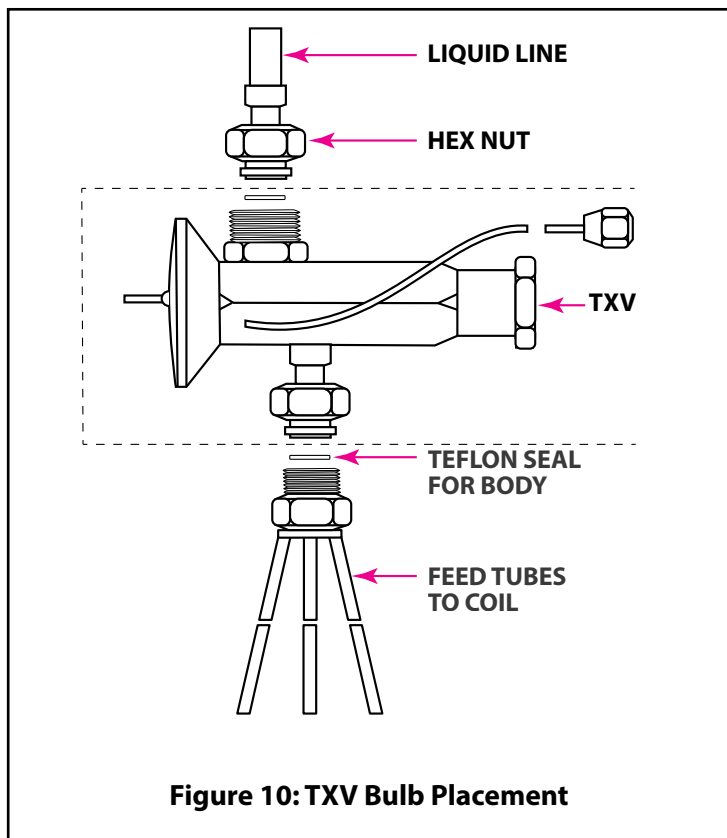

Figure 9: TXV Bulb Placement

Field Installed TXV Installation Procedure

1. Remove the cap on Schrader valve port on coil suction manifold.
2. Depress the Schrader valve to relieve the pressure inside the coil.
3. Only after coil pressure has been relieved, turn the female swivel nut counter-clockwise to separate it from the distributor.
4. Remove the piston orifice from the flowrator distributor assembly using a small diameter wire or paper clip.
5. As shown in Figure 10, the TXV assembly must be installed between the distributor and the liquid line connector.
6. Attach the TXV by connecting the female swivel nut on TXV outlet to the flowrator distributor (aligning Teflon seal first) and torque swivel nut to **10-30 ft. lbs.**
7. Attach the liquid line connector with female swivel nut to male rotolock fitting on TXV inlet (aligning Teflon seal first) and torque swivel nut to **10-30 ft. lbs.**

8. Attach equalizer tubing with 1/4" female flare nut that includes depressor to the male Schrader port on the coil suction manifold and torque nut to **10-30 ft. lbs.**
9. Securely attach the TXV bulb to the suction line using the two bulb clamps furnished with kit.
10. The sensing bulb should be installed outside the coil case on a horizontal section of the suction line if possible (See Figure 8) and should be positioned between 10 o'clock and 2 o'clock as shown in Figure 9.
11. If the sensing bulb must be installed on a vertical section of the suction line, the bulb should be located at least 6 inches away from any bend and on the side of the tube that is above the inside of the bend. On vertical run bulb installations, the bulb should be positioned with the bulb capillary tube at the top.
12. The bulb should be insulated using thermal insulation to protect it from the effect of the surrounding ambient temperature.
13. After completing the TXV installation, leak check all TXV fittings and thoroughly evacuate the coil through the service access fittings on the outdoor unit liquid and suction service valves prior to charging the system with refrigerant.



How the TXV Controls Superheat

The TXV is a precision device designed to regulate the rate at which liquid refrigerant flows into the evaporator. This controlled flow is necessary to provide optimum performance and to prevent the return of liquid refrigerant to the compressor.

The TXV separates the high pressure and low-pressure sides of a refrigeration or air conditioning system. Liquid refrigerant enters the TXV under high pressure, but the pressure is reduced when the flow of the refrigerant is restricted by an internal moving pin and port.

It is important to remember that the TXV only controls the level

of superheat of the refrigerant in the suction line. The TXV is not designed to control air temperature, head pressure, capacity, suction pressure, or humidity. Attempts to adjust the TXV to control any of these system variables will lead to poor system performance and possible compressor failure.

The TXV responds to the temperature of refrigerant gas as it leaves the evaporator. This temperature is detected by the sensing bulb which is located near the evaporator outlet. The TXV also responds to the refrigerant pressure within the evaporator, which is transmitted to the TXV by an equalizer tube connected to the coil suction manifold. By responding to these variables, the TXV maintains a predetermined superheat level exiting the evaporator which maintains proper system stability, performance, and reliability.

TXV TROUBLESHOOTING

The thermostatic expansion valve (TXV) is like the carburetor in a car engine. It opens and closes to allow the correct amount of refrigerant flow through the system. When the TXV isn't working properly, the capacity and efficiency of the system is reduced. If a faulty TXV is suspected, perform the following tests:

1. Connect refrigerant gauges to the system and check that the refrigerant pressures, liquid subcooling and suction superheat levels are correct according to the outdoor unit charging chart. Subcooling at the outdoor unit liquid service valve is normally around 10°F and superheat at the outdoor unit valve is normally between 8-12°F, but these can vary depending on the manufacturer and model of the outdoor unit.
2. Check to see if the indoor airflow through the system is correct. Check to see if the indoor and outdoor coils and indoor air filters are dirty. Clean dirty coils and clean/replace dirty air-filters as necessary before measuring air-flow and checking pressures, superheat, and subcooling.
3. Make sure the refrigerant charge in the system is correct. This step may require weighing the refrigerant in the system. Once refrigerant charge weight has been adjusted as necessary, recheck the pressures, subcooling and superheat. If these values are still not correct, the TXV may be defective or the TXV inlet strainer or the liquid line filter dryer is plugged with debris.
4. Remove the TXV's sensing bulb from the suction line and check the pressures, subcooling, superheat again. No change in the pressures, subcooling, and superheat levels is an indication the TXV is defective.
5. Place the sensing bulb in ice water and recheck the pressures, superheat, and subcooling levels. If these values don't change, the TXV is likely defective.

Additional TXV Troubleshooting Information

Low Suction Pressure – High Superheat

POSSIBLE CAUSES:

1. Undersized TXV
2. TXV superheat adjustment too high
3. High indoor coil pressure drop due to internal restriction
4. TXV sensing bulb installed on bottom of suction line
5. Restricted or capped TXV external equalizer tube
6. Improper TXV external equalizer location (must be located on suction manifold after the last feeder tube)
7. Low refrigerant charge
8. Plugged liquid line filter dryer
9. Plugged TXV inlet strainer
10. Low outdoor ambient temperature

High Suction Pressure – Low Superheat

POSSIBLE CAUSES:

1. Oversized TXV
2. TXV seat leakage
3. TXV superheat adjustment too low
4. Improper TXV sensing bulb installation
 - Poor thermal contact with suction line (loose clamp)
 - Uninsulated sensing bulb
 - Warm location
5. Bad compressor (low capacity)
6. Incorrectly located external equalizer line (must be located on suction manifold after the last feeder tube)

Low Suction Pressure – Low Superheat

POSSIBLE CAUSES:

1. Low system load:
 - Insufficient indoor airflow
 - Dirty indoor air filters
 - Return air too cold
 - Indoor coil icing or frosting
2. Poor air distribution over indoor coil.
3. Improper indoor/outdoor coil internal volume balance on heat pump systems (improper indoor coil/outdoor unit match up; indoor coil too big or too small causing incorrect refrigerant charge balance between cooling and heating modes)
4. Oil trapped in indoor coil

Things To Check Before Replacing TXV

1. Slowly loosen the flare nut on the TXV external equalizer connected to the suction line port with a flare nut. If there is a large pressure release when the nut has been loosened, tighten the nut. If this results in a slight pressure release or no pressure release, the Schrader valve stem is not being depressed. Install an anti-blow back fitting to the external equalizer line of the TXV to depress the Schrader valve stem and check for proper operation of the TXV.
2. Remove the sensing bulb from the suction line and hold in a warm hand. The high side pressure should drop and low side pressure should increase as the TXV opens. Place the sensing bulb in ice water. The high side pressure should increase and the low side pressure should decrease as the TXV closes. If the pressures do not change, the TXV is faulty.

SPECIAL INSTRUCTIONS FOR COILS WITH FLOWRATOR DISTRIBUTOR ASSEMBLIES

The sizing of the orifice piston should be based on the rated capacity of the outdoor unit and coil match-up. Mortex Summit provides capacity performance ratings that match both same size and upsized coils with specific manufacturer's outdoor units. Consult the local Summit distributor for the proper size orifice piston to be used for a specific outdoor unit model number. The factory installed orifice piston size is marked on the flowrator distributor assembly and the coil carton.

Failure to install the proper size orifice piston can lead to poor system performance and possible compressor damage. Variation of one piston size smaller or larger is not normally critical. Mortex/Summit reserves the right to substitute factory installed piston one size smaller or greater if the piston size ordered is out of stock. A selection of replacement orifice pistons is available from the local Summit distributor.

ORIFICE PISTON REPLACEMENT

If the flowrator is being used instead of a TXV, the piston must be installed oriented as shown in Figure 11 in the distributor body and the existing liquid line attached to the flowrator distributor.

1. Remove the cap on Schrader valve port on coil manifold.
2. Depress the Schrader valve to relieve the pressure inside the coil.
3. Only after coil pressure has been relieved, turn the female swivel nut counter-clockwise to separate it from the distributor.
4. Replace the orifice piston with the correct size piston for the application. Make sure the tapered end of the piston is facing the feeder tubes on the distributor body.
5. Turn the female swivel nut clockwise on the flowrator distributor (aligning Teflon seal first) **and torque swivel nut to 10-30 ft. lbs.**
6. After completing the installation of the correct size orifice piston, leak check the flowrator distributor fitting and thoroughly evacuate the system through the service fittings on the outdoor unit liquid and suction service.

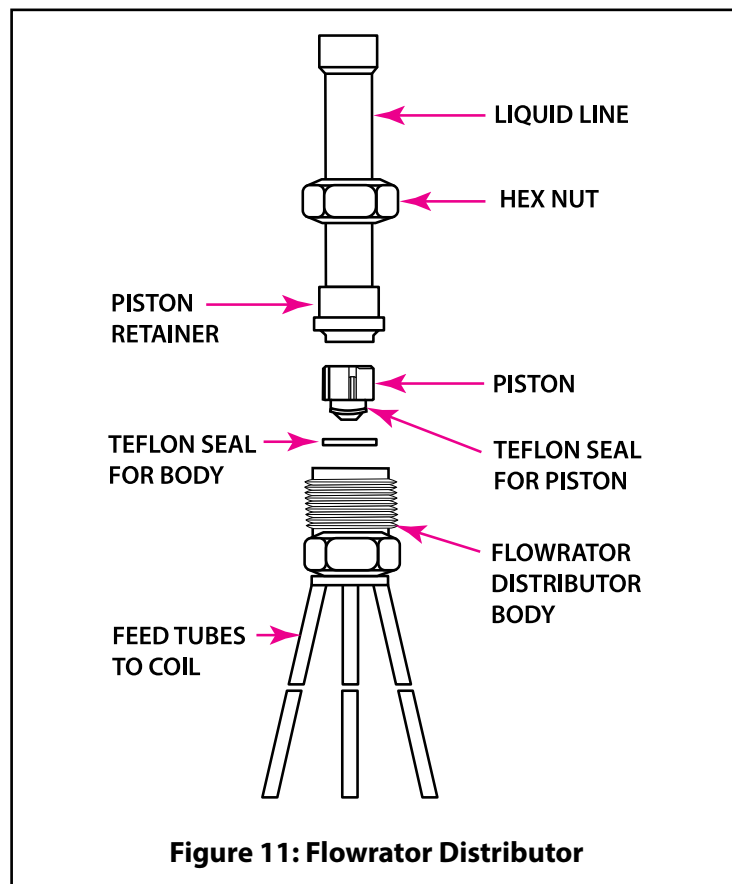

Figure 11: Flowrator Distributor

REFRIGERANT CHARGING PROCEDURE

Specific instructions for refrigerant charging of the system as recommended by the outdoor unit manufacturer should be followed. These instructions will vary for different outdoor unit manufacturers, but are generally as follows:

Coils With Flowrator: Superheat Method/Cooling Mode

Measure the outside ambient temperature, suction pressure and suction line temperature at outdoor unit suction service valve. Adjust the refrigerant charge to achieve the recommended superheat per the outdoor unit manufacturer's specifications.

Coils With TXV: Liquid Line Pressure or Liquid Subcooling Method/Cooling Mode

Measure the outside ambient temperature and liquid line temperature and pressure at the outdoor unit liquid service valve.

Adjust the refrigerant charge to achieve the recommended liquid pressure or liquid subcooling per the outdoor unit manufacturer's specifications.

NOTE: If problems using the outdoor manufacturers suggested charging method are encountered, contact the outdoor unit manufacturer for assistance.

In addition to conventional charging procedures, the following requirements shall be followed.

- Ensure that contamination of different refrigerants does not occur when using charging equipment. Hoses or lines shall be as short as possible to minimize the amount of refrigerant contained in them.
- Cylinders shall be kept in an appropriate position according to the instructions.
- Ensure that the refrigerating system is earthed prior to charging the system with refrigerant.
- Label the system when charging is complete (if not already).
- Extreme care shall be taken not to overfill the refrigerating system.

Prior to recharging the system, it shall be pressure-tested with the appropriate purging gas. The system shall be leak-tested on completion of charging but prior to commissioning. A follow up leak test shall be carried out prior to leaving the site.

Refrigerant Recovery Requirements

When removing refrigerant from a system, either for servicing or decommissioning, it is recommended good practice that all refrigerants are removed safely.

When transferring refrigerant into cylinders, ensure that only appropriate refrigerant recovery cylinders are employed. Ensure that the correct number of cylinders for holding the total system charge is available. All cylinders to be used are designated for the recovered refrigerant and labeled for that refrigerant (i.e: special cylinders for the recovery of refrigerant). Cylinders shall be complete with pressure-relief valve and associated shut-off valves in good working order. Empty recovery cylinders are evacuated and, if possible, cooled before recovery occurs.

The recovery equipment shall be in good working order with a set of instructions concerning the equipment that is at hand and shall be suitable for the recovery of the flammable refrigerant. If in doubt, the manufacturer should be consulted. In addition, a set of calibrated weighing scales shall be available and in good working order. Hoses shall be complete with leak-free disconnect couplings and in good condition.

The recovered refrigerant shall be processed according to local legislation in the correct recovery cylinder, and the relevant waste transfer note arranged. Do not mix refrigerants in recovery units and especially not in cylinders.

If compressors or compressor oils are to be removed, ensure that they have been evacuated to an acceptable level to make certain that flammable refrigerant does not remain within the lubricant. The compressor body shall not be heated by an open flame or other ignition sources to accelerate this process. When oil is drained from a system, it shall be carried out safely.

Complete the refrigerant charge weight field on the outdoor unit rating plate when refrigerant charging is completed. Follow the outdoor unit installation instructions for handling, installation, cleaning, and disposal of the refrigerant.

REFRIGERANT LEAK DETECTION SYSTEM

This coil is equipped with a refrigerant leak detection system consisting of a refrigerant sensor with integral relays to perform the necessary leak mitigation if a refrigerant leak is detected by the sensor (see Figure 12). The refrigerant leak detection system wiring harness pigtailed must be properly connected to the furnace, thermostat, and outdoor unit low voltage control circuit (See Figure 13).

Relocation of Refrigerant Leak Sensor for Horizontal Right Discharge Applications (17.5" Wide and Larger Coils Only)

The flammable refrigerant sensor is installed from the factory for upflow, downflow, and horizontal left discharge applications as shown in Figure 12. For horizontal right discharge applications, the sensor must be relocated to the horizontal right discharge position location on the opposite side of the coil delta plate shown in Figure 12. Screw holes for the alternate sensor location are provided on the coil delta plate.

IMPORTANT

The refrigerant detection system sensor wiring harness plug must be pointing down or horizontal. If the plug is pointing up, condensate could collect in the plug and result in corrosion and/or operational issues. This does not apply to Cubic brand sensors which have a water tight plug and will be pointing up in horizontal applications.

Refrigerant Leak Alarm Output

The coil's refrigerant leak sensor has an alarm output signal that can be used as an input to a building management system or smart thermostat to alert the homeowner or user that the refrigerant detection system has detected a refrigerant leak and is in the leak mitigation mode. There is an ORANGE low voltage pigtail wire in the sensor harness labeled "ALARM". When the sensor is powered and no refrigerant leak is detected, the ORANGE "ALARM" pigtail wire is energized with 24 VAC indicating normal operation. When the refrigerant leak detection system detects a refrigerant leak and enters the leak mitigation mode (indoor blower energized and outdoor unit disabled), the ORANGE "ALARM" pigtail wire will be de-energized (0 VAC). The ORANGE "ALARM" pigtail wire is capped with a wire nut from the factory. Remove this wire nut and connect it to the building management system or smart thermostat as required if a refrigerant leak alert is desired. The building management system or smart thermostat shall be programmed to accept the reverse logic alarm signal (24 VAC – Normal; 0 VAC – Refrigerant Leak).

If a 24 VAC output when a refrigerant leak is detected is required to activate a warning light or audible alarm, the ORANGE "ALARM" pigtail wire shall be connected to the coil of a field supplied relay with normally closed contacts and a 24 VAC coil. An 18 AWG minimum wire from the furnace 24 VAC common circuit shall be connected to the other side of the relay coil. An 18 AWG minimum wire from the furnace 24 VAC "R" transformer circuit shall be connected to the terminal for one side of the normally closed relay contacts and an 18 AWG minimum wire to the warning light or audible alarm shall be connected to terminal for the other side of the normally closed relay contacts. All field supplied wiring shall be protected from damage. When no refrigerant leak is detected, the relay will be energized and the relay contacts will be open,

disconnecting the 24 VAC signal to the warning light or audible alarm. When a refrigerant leak is detected, the relay will be de-energized and the contacts will close sending a 24 VAC signal to the warning light or audible alarm. See Figure 13 for suggested field wiring connections.

⚠ WARNING

This coil is equipped with a refrigerant leak mitigation system that energizes the furnace blower motor to deliver at least the required minimum airflow (See Table 2 or 3) when the refrigerant leak detection system detects a leak. This will dilute the flammable A2L class refrigerant to a point that it no longer poses a risk of an explosion or fire. Follow the procedure (**Verifying Proper Functioning of Refrigerant Leak Mitigation System**) later in this section to confirm the refrigerant mitigation system is functioning as it should. The refrigerant leak detection system wiring harness pigtails must be properly connected to the furnace, thermostat, and outdoor unit low voltage control circuit. (See Figure 13).

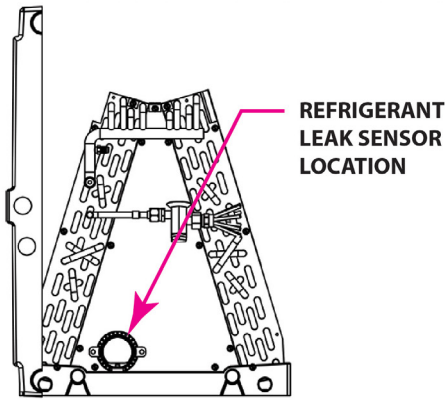

HORIZONTAL LEFT DISCHARGE APPLICATIONS

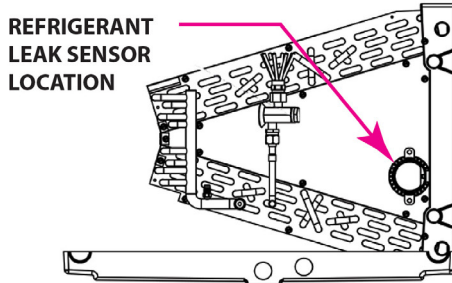

HORIZONTAL RIGHT DISCHARGE APPLICATIONS

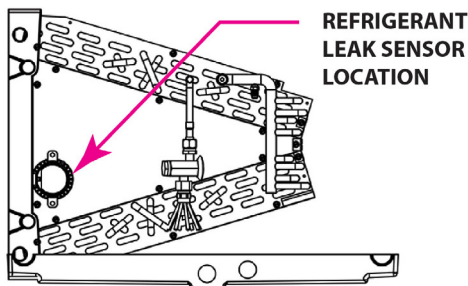

Figure 12: Refrigerant Leak Detection Sensor Location

Refrigerant Detection System Wiring Connections (See Figure 13)

Make sure the leak detection system sensor wiring harness is plugged into the mating plug on the sensor. Route the sensor wiring harness through the bushing in the coil case so it is outside the coil case. Connect the sensor harness pigtail wires to the furnace, thermostat, and outdoor unit low voltage control circuit as follows.

1. Connect the RED sensor pigtail wire labeled "R" to the "R" terminal on the furnace low voltage terminal block.
 2. Connect the BLACK sensor pigtail wire labeled "COM" to the "C" or "COM" terminal on the furnace low voltage terminal block.
 3. Connect the YELLOW sensor pigtail wire labeled "Y-Tstat" to the "Y" or "Y1" terminal on the furnace low voltage terminal block. If the furnace low voltage terminal block does not have a "Y" or "Y1" terminal, connect the YELLOW sensor pigtail wire to the low voltage wire coming from the "Y" or "Y1" terminal on the thermostat.
 4. Connect the WHITE sensor pigtail wire labeled "Y-CC" to the low voltage wire coming from the "Y" or "Y1" terminal on the outdoor unit. If the outdoor unit does not have a "Y" or "Y1" terminal, connect the WHITE sensor pigtail wire labeled "Y-CC" to the wire coming from the low voltage pigtail on the outdoor unit that is connected to the compressor contactor coil.
- NOTE:** Do not connect the WHITE sensor pigtail wire labeled "Y-CC" to the common (COM) wire coming from the outdoor unit compressor contactor coil.
5. Connect the BLUE sensor pigtail wire labeled "G" to the "G" terminal on the furnace low voltage terminal block.
 6. If a refrigerant leak alert is desired and a building management system or smart thermostat capable of providing that alert is being used, removed the wire nut from the end of the ORANGE sensor pigtail wire labeled "ALARM" and connect it to the appropriate building management system or smart thermostat connections. See "Refrigerant Leak Alarm Output" on the previous page for additional information.

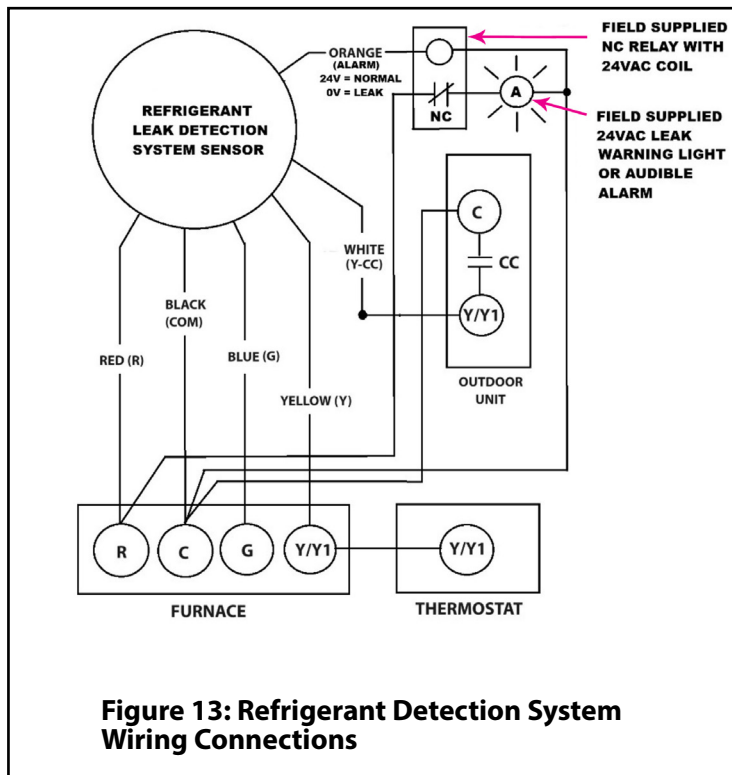

Figure 13: Refrigerant Detection System Wiring Connections

Minimum Circulating Airflow for Refrigerant Leak Mitigation

There is a minimum circulating airflow required when the refrigerant leak detection system is operating in the leak mitigation mode. This minimum depends on the total system refrigerant charge and can be found listed in Tables 2 and 3. The refrigerant mitigation system energizes the continuous fan function on the furnace or air handler. The continuous fan CFM (l/s) may need to be increased to achieve the minimum leak mitigation circulating airflow level by changing to a different indoor blower motor speed tap or ECM motor setting that delivers the minimum mitigation airflow level. Refer to the furnace or air handler blower performance tables and wiring diagrams in the manufacturer's installation manual to determine if this adjustment is necessary and if it is determined to be necessary to increase the continuous fan airflow level, follow the instructions in that manual to make the necessary adjustment. the instructions in that manual to make the necessary adjustment.

Refrigerant Detection System Sequence of Operation

Should a refrigerant leak occur in the indoor coil, the refrigerant leak detection system will energize the indoor blower and will open the 24VAC circuit to the outdoor unit compressor contactor. The circulation of air will disperse the leaked flammable refrigerant into the conditioned space where it will be diluted to point where it can no longer be ignited by an ignition source. The indoor blower will continue to operate until 5 minutes after the concentration of the refrigerant at the sensor drops below the sensor's setpoint. Should the concentration of the refrigerant rise above the setpoint of the sensor, the cycle will repeat until the refrigerant concentration stays below the setpoint of the sensor. The sensor pigtail marked "ALARM" will normally be energized with 24VAC when no leak is detected and will be de-energized when a leak is detected for the purpose of notifying a building management system to issue a refrigerant leak alarm or to energize a leak warning light or audible alarm if a field supplied normally closed relay is installed (See Figure 13).

Should the sensor fail or if the sensor wiring is damaged or disconnected, the sensor will automatically enter the mitigation mode until the sensor is replaced or the wiring is reconnected or repaired.

Verifying Proper Functioning of Refrigerant Leak Mitigation System

Follow the steps below to verify the proper functioning of the Refrigerant Leak Mitigation System.

1. Remove the coil access panel from the front of the coil or air handler.
2. Locate the black refrigerant sensor located near the bottom front of the coil assembly (see Figure 12).

Leak Detected During Cooling Cycle

3. Set the thermostat to "COOL" and the fan switch to "AUTO" and lower the temperature setpoint below the indoor temperature so the system enters the cooling mode.
4. Confirm the outdoor unit compressor is operating.
5. Within 30 seconds of the compressor starting, release a small amount of refrigerant on the refrigerant sensor to activate the leak mitigation mode.
6. Confirm the outdoor unit compressor and fan motor shut down and the indoor blower continues to operate.
7. Confirm the indoor blower is energized and 24V is not present at the refrigerant leak detection sensor pigtail labeled "ALARM".
8. Confirm the outdoor unit compressor and fan motor are reenergized approximately 5 minutes after the flow of refrigerant near the sensor has ended and that the indoor blower continues to operate.

Leak Detected During the OFF Cycle

9. Set the thermostat to the "OFF" position and wait until the outdoor unit compressor and fan motor stop and indoor blower stops.
10. Release a small amount of refrigerant on the refrigerant sensor to activate the leak mitigation mode.
11. Confirm the indoor blower is energized and 24V is not present at the coil pigtail marked "ALARM".
12. Confirm the indoor blower shuts down after approximately 5 minutes after the flow of refrigerant on the refrigerant sensor has ended.
13. If the Refrigerant Leak Mitigation System does not operate as stated above, check for loose wiring connections or replace the refrigerant sensor.
14. Reinstall the coil access panel on the coil or air handler.
15. Set the thermostat to the desired operating mode and temperature.

If the leak detection system does not function properly when subjected to the above procedure, check for miswiring of the system. If the wiring connections are found to be correct per the coil or air handler wiring diagram, replace the sensor with an approved replacement from the manufacturer.

Leak Detection Sensor Replacement

When the refrigerant leak detection system sensor fails or reaches the end of its life, the leak detection system will enter and remain in the leak mitigation mode even though there is no refrigerant leak present. If the leak detection system continues to operate in the mitigation mode even when a refrigerant leak isn't indicated by a portable refrigerant leak detector, replace the sensor with an

approved replacement from the air coil manufacturer. Disconnect the wiring harness connector from the failed sensor and remove the sensor mounting screws. Discard the failed sensor. Mount the replacement sensor in the same location as the failed sensor that was removed and connect the sensor wiring harness connector to the sensor. Verify the proper function of the refrigerant leak mitigation system using the **“Verifying Proper Functioning of Refrigerant Leak Mitigation System”** procedure above.



IMPORTANT

Mortex may source sensors from various manufacturers that have a different wiring harness connection. A wiring may be necessary to allow the replacement sensor to connect the sensor wiring harness. The wiring adapter will be provided with the replacement sensor. Alternate mounting holes are provided in the coil delta plate to accommodate the various approved sensors. Only use a replacement sensor approved by and provided by Mortex to assure proper operation and compatibility.

Only the following replacement refrigerant sensors may be used for Mortex products:

R-32 Refrigerant: R68ALL001

R-454B Refrigerant: R68ALL002

R-32/R-454B Refrigerant (Dual Refrigerant Sensor): R68ALL003

IMPORTANT: The sensor wiring harness plug must be pointing down or horizontal. If the plug is pointing up, water could collect in the plug and result in operational issues. This does not apply to Cubic brand sensors which have a water tight plug and will be pointing up in horizontal applications.

Total System Refrigerant Charge (kg)	Total System Refrigerant Charge (oz)	Total System Refrigerant Charge (lb)	Min. Area of Conditioned Space (m ²)	Min. Area of Conditioned Space (ft ²)	Min. Air-Flow (meter ³ /hr)	Min. Air-Flow (liter/s)	Min. Air-Flow (CFM)
1.776 kg or less	62.6 oz or less	3.91 lb or less	No Minimum	No Minimum	No Minimum	No Minimum	No Minimum
1.78	63	3.92	5.47	59	180	50	106
1.92	68	4.22	5.88	63	194	54	114
2.05	72	4.52	6.30	68	208	58	122
2.19	77	4.82	6.72	72	222	62	131
2.32	82	5.12	7.14	77	236	65	139
2.46	87	5.42	7.56	81	249	69	147
2.60	92	5.72	7.97	86	263	73	155
2.73	96	6.02	8.39	90	277	77	163
2.87	101	6.32	8.81	95	291	81	171
3.00	106	6.62	9.23	99	305	85	179
3.14	111	6.92	9.65	104	318	88	187
3.28	116	7.22	10.06	108	332	92	195
3.41	120	7.52	10.48	113	346	96	204
3.55	125	7.82	10.90	117	360	100	212
3.69	130	8.12	11.32	122	374	104	220
3.82	135	8.42	11.74	126	387	108	228
3.96	140	8.73	12.15	131	401	111	236
4.09	144	9.03	12.57	135	415	115	244
4.23	149	9.33	12.99	140	429	119	252
4.37	154	9.63	13.41	144	442	123	260
4.50	159	9.93	13.83	149	456	127	269
4.64	164	10.23	14.24	153	470	131	277
4.77	168	10.53	14.66	158	484	134	285
4.91	173	10.83	15.08	162	498	138	293
5.05	178	11.13	15.50	167	511	142	301
5.18	183	11.43	15.92	171	525	146	309
5.32	188	11.73	16.33	176	539	150	317
5.45	192	12.03	16.75	180	553	154	325
5.59	197	12.33	17.17	185	567	157	333
5.73	202	12.63	17.59	189	580	161	342
5.86	207	12.93	18.01	194	594	165	350
6.00	212	13.23	18.42	198	608	169	358
6.14	216	13.53	18.84	203	622	173	366
6.27	221	13.83	19.26	207	636	177	374
6.41	226	14.13	19.68	212	649	180	382
6.54	231	14.43	20.10	216	663	184	390
6.68	236	14.73	20.51	221	677	188	398
6.82	240	15.03	20.93	225	691	192	407
6.95	245	15.33	21.35	230	705	196	415
7.09	250	15.63	21.77	234	718	200	423
7.22	255	15.93	22.19	239	732	203	431
7.36	260	16.23	22.60	243	746	207	439
7.50	264	16.53	23.02	248	760	211	447
7.63	269	16.83	23.44	252	774	215	455
7.77	274	17.13	23.86	257	787	219	463
7.90	279	17.43	24.28	261	801	223	471
8.04	284	17.73	24.69	266	815	226	480
8.18	288	18.03	25.11	270	829	230	488
8.31	293	18.33	25.53	275	843	234	496
8.45	298	18.63	25.95	279	856	238	504
8.59	303	18.93	26.37	284	870	242	512
8.72	308	19.23	26.78	288	884	246	520
8.86	312	19.53	27.20	293	898	249	528
8.99	317	19.83	27.62	297	911	253	536

TABLE 2: MINIMUM CONDITIONED SPACE AREA & AIR-FLOW FOR R-454B REFRIGERANT INSTALLATIONS

- NOTES: 1. Applies to fixed ducted systems with continuous air-flow or refrigerant detection systems only.
2. Based on LFL of 0.296 kg/m³**

Total System Refrigerant Charge (kg)	Total System Refrigerant Charge (oz)	Total System Refrigerant Charge (lb)	Min. Area of Conditioned Space (m ²)	Min. Area of Conditioned Space (ft ²)	Min. Air-Flow (meter ³ /hr)	Min. Air-Flow (liter/s)	Min. Air-Flow (CFM)
1.836 kg or less	64.6 oz or less	4.04 lb or less	No Minimum	No Minimum	No Minimum	No Minimum	No Minimum
1.84	65	4.06	5.47	59	180	50	106
1.98	70	4.36	5.87	63	194	54	114
2.11	75	4.66	6.28	68	207	58	122
2.25	79	4.96	6.68	72	220	61	130
2.38	84	5.26	7.08	76	234	65	138
2.52	89	5.56	7.49	81	247	69	145
2.66	94	5.86	7.89	85	260	72	153
2.79	99	6.16	8.30	89	274	76	161
2.93	103	6.46	8.70	94	287	80	169
3.06	108	6.76	9.11	98	300	83	177
3.20	113	7.06	9.51	102	314	87	185
3.34	118	7.36	9.91	107	327	91	193
3.47	123	7.66	10.32	111	341	95	200
3.61	127	7.96	10.72	115	354	98	208
3.75	132	8.26	11.13	120	367	102	216
3.88	137	8.56	11.53	124	381	106	224
4.02	142	8.86	11.94	128	394	109	232
4.15	147	9.16	12.34	133	407	113	240
4.29	151	9.46	12.74	137	421	117	248
4.43	156	9.76	13.15	142	434	121	255
4.56	161	10.06	13.55	146	447	124	263
4.70	166	10.36	13.96	150	461	128	271
4.83	171	10.66	14.36	155	474	132	279
4.97	175	10.96	14.77	159	487	135	287
5.11	180	11.26	15.17	163	501	139	295
5.24	185	11.56	15.57	168	514	143	302
5.38	190	11.86	15.98	172	527	146	310
5.51	195	12.16	16.38	176	541	150	318
5.65	199	12.46	16.79	181	554	154	326
5.79	204	12.76	17.19	185	567	158	334
5.92	209	13.06	17.60	189	581	161	342
6.06	214	13.36	18.00	194	594	165	350
6.20	219	13.66	18.41	198	607	169	357
6.33	223	13.96	18.81	202	621	172	365
6.47	228	14.26	19.21	207	634	176	373
6.60	233	14.56	19.62	211	647	180	381
6.74	238	14.86	20.02	216	661	184	389
6.88	243	15.16	20.43	220	674	187	397
7.01	247	15.46	20.83	224	687	191	405
7.15	252	15.76	21.24	229	701	195	412
7.28	257	16.06	21.64	233	714	198	420
7.42	262	16.36	22.04	237	727	202	428
7.56	267	16.66	22.45	242	741	206	436
7.69	271	16.96	22.85	246	754	209	444
7.83	276	17.26	23.26	250	767	213	452
7.96	281	17.56	23.66	255	781	217	460
8.10	286	17.86	24.07	259	794	221	467
8.24	291	18.16	24.47	263	808	224	475
8.37	295	18.46	24.87	268	821	228	483
8.51	300	18.76	25.28	272	834	232	491
8.65	305	19.06	25.68	276	848	235	499
8.78	310	19.36	26.09	281	861	239	507
8.92	315	19.66	26.49	285	874	243	514
9.05	319	19.96	26.90	290	888	247	522

TABLE 3: MINIMUM CONDITIONED SPACE AREA & AIR-FLOW FOR R-32 REFRIGERANT

**NOTES: 1. Applies to fixed ducted systems with continuous air-flow or refrigerant detection systems
2. Based on LFL of 0.306 kg/m³**

DECOMMISSIONING AND DISPOSAL OF THE COIL

When the coil is at the end of its life and is being removed for replacement, proper procedures must be followed to assure the safety of the technician and building occupants due to the flammable refrigerant contained in the refrigeration system. Before carrying out this procedure, it is essential that the technician is completely familiar with the equipment and all its detail. It is recommended good practice that all refrigerants are recovered safely. Prior to the task being carried out, an oil and refrigerant sample shall be taken in case analysis is required prior to re-use of recovered refrigerant. It is essential that electrical power is available before the task is commenced.

Decommissioning Procedure

- a. Become familiar with the equipment and its operation.
- b. Before attempting the procedure, ensure that:
 - Mechanical handling equipment is available, if required, for handling refrigerant cylinders;
 - All personal protective equipment is available and being used correctly;
 - The recovery process is supervised at all times by a competent person;
 - Recovery equipment and cylinders conform to the appropriate standards.
- c. Pump down the refrigerant into the outdoor unit if possible by closing the outdoor unit liquid service valve and energizing the compressor until the suction pressure is near atmospheric pressure. If pumping the system down is not possible due to an inoperable compressor, the refrigerant must be recovered following local and national regulations.
- d. If a vacuum is not possible, make a manifold so that refrigerant can be removed from various parts of the system.
- e. Make sure that the recovery cylinder is situated on the scales before recovery takes place.
- f. Start the recovery machine and operate in accordance with instructions. (Also refer to **Refrigerant Recovery Requirements** in the next column.)
- g. Do not overfill cylinders (no more than 80 % volume liquid charge).
- h. Do not exceed the maximum working pressure of the cylinder, even temporarily.
- i. When the cylinders have been filled correctly and the process completed, make sure that the cylinders and the equipment are removed from site promptly and all isolation valves on the equipment are closed off.
- j. Recovered refrigerant shall not be charged into another refrigerating system unless it has been cleaned and checked.
- k. Once all of the refrigerant has been pumped into the outdoor unit or has been recovered, disconnect the refrigerant lines from the coil. Continuously flush or purge with inert gas when using a flame to open the circuit at the field refrigerant line connections.
- l. Turn the circuit breaker(s) serving the furnace or air handler in the main electrical panel to the OFF position or if a disconnect switch has been installed near the furnace or air handler, switch it to the OFF position.

- m. Disconnect all electrical wiring from the coil.
- n. Once the refrigerant lines and electrical wiring have been disconnected from the coil, remove the coil from the property and dispose of it. Taking the coil to a recycling center is encouraged.
- o. Equipment shall be labeled stating that it has been decommissioned and emptied of refrigerant. The label shall be dated and signed. For appliances containing flammable refrigerants, ensure that there are labels on the equipment stating the equipment contains flammable refrigerant.

Refrigerant Recovery Requirements

When removing refrigerant from a system, either for servicing or decommissioning, it is recommended good practice that all refrigerants are removed safely.

When transferring refrigerant into cylinders, ensure that only appropriate refrigerant recovery cylinders are employed. Ensure that the correct number of cylinders for holding the total system charge is available. All cylinders to be used are designated for the recovered refrigerant and labeled for that refrigerant (i.e: special cylinders for the recovery of refrigerant). Cylinders shall be complete with pressure-relief valve and associated shut-off valves in good working order. Empty recovery cylinders are evacuated and, if possible, cooled before recovery occurs.

The recovery equipment shall be in good working order with a set of instructions concerning the equipment that is at hand and shall be suitable for the recovery of the flammable refrigerant. If in doubt, the manufacturer should be consulted. In addition, a set of calibrated weighing scales shall be available and in good working order. Hoses shall be complete with leak-free disconnect couplings and in good condition.

The recovered refrigerant shall be processed according to local legislation in the correct recovery cylinder, and the relevant waste transfer note arranged. Do not mix refrigerants in recovery units and especially not in cylinders. If compressors or compressor oils are to be removed, ensure that they have been evacuated to an acceptable level to make certain that flammable refrigerant does not remain within the lubricant. The compressor body shall not be heated by an open flame or other ignition sources to accelerate this process. When oil is drained from a system, it shall be carried out safely.

Disposal of the Coil

- Ensure sufficient ventilation at the working place.
- Remove the refrigerant. If the recovery is not required by national regulations, drain the refrigerant to the outside. Take care that the drained refrigerant will not cause any danger. In doubt, one person should guard the outlet. Take special care that drained refrigerant will not float back into the building.
- When flammable refrigerants are used,
 - evacuate the refrigerant circuit.
 - purge the refrigerant circuit with oxygen free nitrogen.