



## Vertical A Coil and Cabinet CA-W Cased A Coil Series

### ***STANDARD SPECIFICATIONS***

- Removable front panels for easy accessibility
- Removable flanges mount at either cabinet end.
- Fits most existing furnaces
- Available in A/C and HP Models
- TXV with Check Valve for HP operation
- Optional Flow-Rator Pistons with Check Valve are available
- Left and Right Handed drain connections are standard
- Dual 3/4" FPT drains on each side
- All units are factory leak tested at 500 psi and sealed
- Left handed refrigerant connections are standard
- Schrader port connections are standard for pressure verification
- Coils are AHRI rated with most outdoor A/C and HP units
- Ideal for new construction and replacement markets
- Injection molded high temperature UL: approved plastic upflow drain pan.
- Vacuum formed high impact UL approved PVC Horizontal drain pan
- Refrigerant connections are SWAGED and factory sealed with a nitrogen holding charge
- Fully Insulated cabinets

# CA-W Cased A Coil Series

Designed for Upflow and Downflow Installations – 1 ½ - 5 Tons

## Description:

The CA-W series is a high efficiency vertical A coil and cabinet designed to be installed on new style and existing gas and electric furnaces. The easily installed unit works in vertical mounting positions and is ideal for the new construction and replacement markets. The CA-W series is AHRI rated to provide appropriate SEERs and capacities. These units are ULus & ULc approved.

## Options:

- Factory installed thermal expansion valve (TXV).
- Field installed thermal expansion valve (TXV3 screw-in type kit).
- Desert Sand Beige painted cabinet.
- Custom labels.

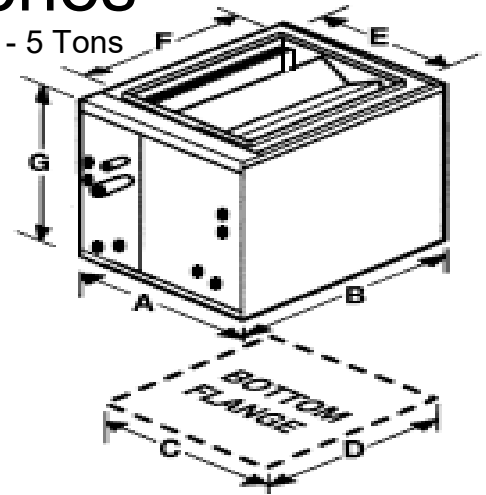

## Physical Dimensions

Coil Model	Cabinet Suffix	A	B	C	D	E	F	G
CA0XXA820 or CA0XXA860	-WA1*	14	21	12 3/4	20 1/4	12 3/4	19 1/4	16
	-WA*	14 1/2	21	13 1/4	20 1/4	12 3/4	19 1/4	16
	-WB*	15 1/2	21	14 1/4	20 1/4	13 3/4	19 1/4	16
	-WB1	16 1/2	21	15 1/4	20 1/4	14 3/4	19 1/4	16
	-WC*	17 1/2	21	16 1/4	20 1/4	15 3/4	19 1/4	16
CA0XXA821 or CA0XXA861	-WA1*	14	21	12 3/4	20 1/4	12 3/4	19 1/4	16
	-WA*	14 1/2	21	13 1/4	20 1/4	12 3/4	19 1/4	16
	-WB*	15 1/2	21	14 1/4	20 1/4	13 3/4	19 1/4	16
	-WB1	16 1/2	21	15 1/4	20 1/4	14 3/4	19 1/4	16
	-WC	17 1/2	21	16 1/4	20 1/4	15 3/4	19 1/4	16
CA0XXA822 or CA0XXA862	-WD	19 1/4	21	17 7/8	20 1/4	17 3/8	19 1/4	16
	-WE1	20 1/2	21	19 1/4	20 1/4	18 3/4	19 1/4	16
	-WE	21	21	19 3/4	20 1/4	19 1/4	19 1/4	16
	-WA1*	14	21	12 3/4	20 1/4	12 3/4	19 1/4	18
	-WA*	14 1/2	21	13 1/4	20 1/4	12 3/4	19 1/4	18
	-WB*	15 1/2	21	14 1/4	20 1/4	13 3/4	19 1/4	18
	-WB1	16 1/2	21	15 1/4	20 1/4	14 3/4	19 1/4	18
CA0XXA823 or CA0XXA863	-WC	17 1/2	21	16 1/4	20 1/4	15 3/4	19 1/4	18
	-WD	19 1/2	21	17 7/8	20 1/4	17 3/8	19 1/4	18
	-WE1	20 1/2	21	19 1/4	20 1/4	18 3/4	19 1/4	18
	-WE	21	21	19 3/4	20 1/4	19 1/4	19 1/4	18
	-WF	22 3/4	21	21 1/2	20 1/4	21	19 1/4	18
	-WF1	23 1/2	21	22 3/4	20 1/4	21 3/4	19 1/4	18
	-WG	24 1/2	21	23 1/4	20 1/4	22 3/4	19 1/4	18
	-WC	17 1/2	21	16 1/4	20 1/4	15 3/4	19 1/4	24
	-WD	19 1/4	21	17 7/8	20 1/4	17 3/8	19 1/4	24
	-WE1	20 1/2	21	19 1/4	20 1/4	18 3/4	19 1/4	24

Coil Model	Cabinet Suffix	A	B	C	D	E	F	G
CA0XXA824 or CA0XXA864 or CA0XXA894	-WB*	15 1/2	21	14 1/4	20 1/4	13 3/4	19 1/4	20
	-WB1	16 1/2	21	15 1/4	20 1/4	14 3/4	19 1/4	20
	-WC	17 1/2	21	16 1/4	20 1/4	15 3/4	19 1/4	20
	-WD	19 1/4	21	17 7/8	20 1/4	17 3/8	19 1/4	20
	-WE1	20 1/2	21	19 1/4	20 1/4	18 3/4	19 1/4	20
	-WE	21.00	21	19 3/4	20 1/4	19 1/4	19 1/4	20
	-WF	22 3/4	21	21 1/2	20 1/4	21	19 1/4	20
	-WF1	23 1/2	21	22 3/4	20 1/4	21 3/4	19 1/4	20
CA0XXA865 or CA0XXA895	-WG	24 1/2	21	23 1/4	20 1/4	22 3/4	19 1/4	20
	-WB*	15 1/2	21	14 1/4	20 1/4	13 1/4	19 1/4	24
	-WB1	16 1/2	21	15 1/4	20 1/4	14 3/4	19 1/4	24
	-WC	17 1/2	21	16 1/4	20 1/4	15 3/4	19 1/4	24
	-WD	19 1/4	21	17 7/8	20 1/4	17 3/8	19 1/4	24
	-WE1	20 1/2	21	19 1/4	20 1/4	18 3/4	19 1/4	24
	-WE	21.00	21	19 3/4	20 1/4	19 1/4	19 1/4	24
	-WF	22 3/4	21	21 1/2	20 1/4	21	19 1/4	24
CA0XXA866 or CA0XXA896	-WF1	23 1/2	21	22 3/4	20 1/4	21 3/4	19 1/4	24
	-WG	24 1/2	21	23 1/4	20 1/4	22 3/4	19 1/4	26
	-WC	17 1/2	21	16 1/4	20 1/4	15 3/4	19 1/4	24
	-WD	19 1/4	21	17 7/8	20 1/4	17 3/8	19 1/4	24
	-WE1	20 1/2	21	19 1/4	20 1/4	18 3/4	19 1/4	24
	-WE	21.00	21	19 3/4	20 1/4	19 1/4	19 1/4	24
CA0XXA867 or CA0XXA897	-WF	22 3/4	21	21 1/2	20 1/4	21	19 1/4	24
	-WF1	23 1/2	21	22 3/4	20 1/4	21 3/4	19 1/4	24
	-WG	24 1/2	21	23 1/4	20 1/4	22 3/4	19 1/4	26
	-WD	19 1/4	21	17 7/8	20 1/4	17 3/8	19 1/4	26
	-WE1	20 1/2	21	19 1/4	20 1/4	18 3/4	19 1/4	26
	-WE	21.00	21	19 3/4	20 1/4	19 1/4	19 1/4	26
	-WF	22 3/4	21	21 1/2	20 1/4	21	19 1/4	26

**NOTE:** Evaporator coils equipped with a 15%-bleed type expansion valve must be used with condensing units equipped with hard start components.

**NOTE:** Center line of the drains located from pan corner, 1 ½" for primary and 3 ½" for secondary.

**NOTE: Standard coils shown in bold type.**

\* Use only with 3 tons or less applications.

