



Summit CD Series Dedicated Horizontal Plenum Coil

STANDARD SPECIFICATIONS

- Rifled copper tubing with high performance aluminum fins.
- AHRI certified applications for A/C and heat pump systems.
- UL listed and factory leak tested at 500 psi.
- Factory-installed TXV.
- Top mounted sweat refrigerant lines for ease of installation and service.
- Built-in plastic horizontal drain pan.
- 3/4" Drain connections on both sides of coil for multiple installation options.
- 1" foil backed faced fiberglass duct-board for collar connections.
- Rigid galvanized steel construction for long life durability.

Dedicated Horizontal Cased Coil shown with Quick PlenumTM (QP Series)TM

Features of CD Series Coil

- Bi-Directional air flow not required due to dual drain connections on each side and external top mounted piston/orifice connection.
- Vacuum formed high impact UL Approved PVC pan.

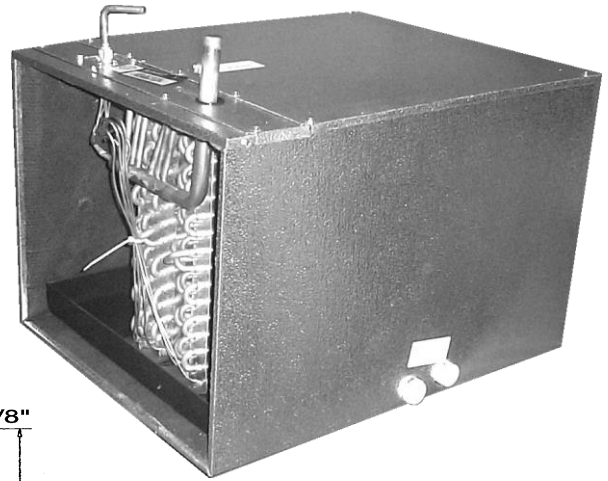

CD SeriesTM
Dedicated
Horizontal
A-Coil Cabinet

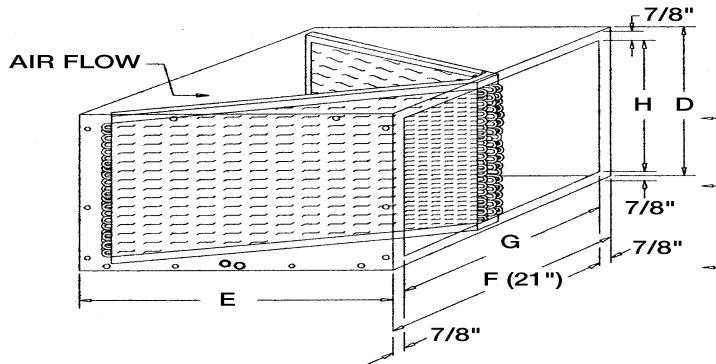

Evaporator Coil Model	Evap. Coil Cabinet	Quick Plenum	QP Series Quick Plenum Outside Dia. (In.)			CD Series Ccoil Cabinet Outside Dia. (In.)			CD Series Coil Supply Openings (in.)	
			A	B	C	D	E	F	G	H
CD0XXA82G	DA1-22.5	QPA1-24	14	24	21	14	22.5	21	20.5	12.5
CD0XXA82G	DA1-22.5	QPA1-30	14	30	21	14	22.5	21	20.5	12.5
CD0XXA86G	DA1-22.5	QPA1-24	14	24	21	14	22.5	21	20.5	12.5
CD0XXA86G	DA1-22.5	QPA1-30	14	30	21	14	22.5	21	20.5	12.5
CD0XXA52G	DA1-26.5	QPA1-24	14	24	21	14	26.5	21	20.5	12.5
CD0XXA52G	DA1-26.5	QPA1-30	14	30	21	14	26.5	21	20.5	12.5
CD0XXA56G	DA1-26.5	QPA1-24	14	24	21	14	26.5	21	20.5	12.5
CD0XXA56G	DA1-26.5	QPA1-30	14	30	21	14	26.5	21	20.5	12.5
CD0XXA59G	DA1-26.5	QPA1-24	14	24	21	14	26.5	21	20.5	12.5
CD0XXA59G	DA1-26.5	QPA1-30	14	30	21	14	26.5	21	20.5	12.5
CD0XXA822	DA-22.5	QPA-24	14.5	24	21	14.5	22.5	21	20.5	13
CD0XXA822	DA-22.5	QPA-30	14.5	30	21	14.5	22.5	21	20.5	13
CD0XXA862	DA-22.5	QPA-24	14.5	24	21	14.5	22.5	21	20.5	13
CD0XXA862	DA-22.5	QPA-30	14.5	30	21	14.5	22.5	21	20.5	13
CD0XXA892	DA-22.5	QPA-24	14.5	24	21	14.5	22.5	21	20.5	13
CD0XXA892	DA-22.5	QPA-30	14.5	30	21	14.5	22.5	21	20.5	13
CD0XXA522	DA-26.5	QPA-24	14.5	24	21	14.5	26.5	21	20.5	13
CD0XXA522	DA-26.5	QPA-30	14.5	30	21	14.5	26.5	21	20.5	13
CD0XXA562	DA-26.5	QPA-24	14.5	24	21	14.5	26.5	21	20.5	13
CD0XXA562	DA-26.5	QPA-30	14.5	30	21	14.5	26.5	21	20.5	13
CD0XXA592	DA-26.5	QPA-24	14.5	24	21	14.5	26.5	21	20.5	13
CD0XXA592	DA-26.5	QPA-30	14.5	30	21	14.5	26.5	21	20.5	13
CD0XXA82E	DB-22.5	QPB-24	15.5	24	21	15.5	22.5	21	20.5	14
CD0XXA82E	DB-22.5	QPB-30	15.5	30	21	15.5	22.5	21	20.5	14
CD0XXA86E	DB-22.5	QPB-24	15.5	24	21	15.5	22.5	21	20.5	14
CD0XXA86E	DB-22.5	QPB-30	15.5	30	21	15.5	22.5	21	20.5	14
CD0XXA52E	DB-26.5	QPB-24	15.5	24	21	15.5	26.5	21	20.5	14
CD0XXA52E	DB-26.5	QPB-30	15.5	30	21	15.5	26.5	21	20.5	14
CD0XXA56E	DB-26.5	QPB-24	15.5	24	21	15.5	26.5	21	20.5	14
CD0XXA56E	DB-26.5	QPB-30	15.5	30	21	15.5	26.5	21	20.5	14
CD0XXA59E	DB-26.5	QPB-24	15.5	24	21	15.5	26.5	21	20.5	14
CD0XXA59E	DB-26.5	QPB-30	15.5	30	21	15.5	26.5	21	20.5	14

Dedicated Horizontal Cased Coil shown with Quick Plenum™ (QP Series)™

QP Series™
Duct Board
Plenum Section
Patent Pending

Features of QP Series Coil Plenum

- Bi-Directional air flow not required due to dual drain connections on each side and external top mounted piston/orifice connection.
- Vacuum formed high impact UL Approved PVC pan.

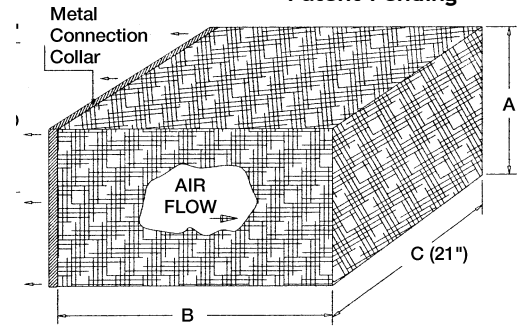

Evaporator Coil	Evap. Coil Cabinet	Quick Plenum	QP Series Quick Plenum Outside Dim. (IN)			CD Series Coil Cabinet Outside Dim. (IN)			CD Series Coil Supply Openings (IN)	
			A	B	C	D	E	F	G	H
CD0XXA823	DB1-22.5	QPB1-24	16.5	24	21	16.5	22.5	21	20.5	15
CD0XXA823	DB1-22.5	QPB1-30	16.5	30	21	16.5	22.5	21	20.5	15
CD0XXA863	DB1-22.5	QPB1-24	16.5	24	21	16.5	22.5	21	20.5	15
CD0XXA863	DB1-22.5	QPB1-30	16.5	30	21	16.5	22.5	21	20.5	15
CD0XXA523	DB1-26.5	QPB1-24	16.5	24	21	16.5	26.5	21	20.5	15
CD0XXA523	DB1-26.5	QPB1-30	16.5	30	21	16.5	26.5	21	20.5	15
CD0XXA563	DB1-26.5	QPB1-24	16.5	24	21	16.5	26.5	21	20.5	15
CD0XXA563	DB1-26.5	QPB1-30	16.5	30	21	16.5	26.5	21	20.5	15
CD0XXA593	DB1-26.5	QPB1-24	16.5	24	21	16.5	26.5	21	20.5	15
CD0XXA593	DB1-26.5	QPB1-30	16.5	30	21	16.5	26.5	21	20.5	15
CD0XXA82C	DC-22.5	QPC-24	17.5	24	21	17.5	22.5	21	20.5	16
CD0XXA82C	DC-22.5	QPC-30	17.5	30	21	17.5	22.5	21	20.5	16
CD0XXA86C	DC-22.5	QPC-24	17.5	24	21	17.5	22.5	21	20.5	16
CD0XXA86C	DC-22.5	QPC-30	17.5	30	21	17.5	22.5	21	20.5	16
CD0XXA52C	DC-26.5	QPC-24	17.5	24	21	17.5	26.5	21	20.5	16
CD0XXA52C	DC-26.5	QPC-30	17.5	30	21	17.5	26.5	21	20.5	16
CD0XXA56C	DC-26.5	QPC-24	17.5	24	21	17.5	26.5	21	20.5	16
CD0XXA56C	DC-26.5	QPC-30	17.5	30	21	17.5	26.5	21	20.5	16
CD0XXA59C	DC-26.5	QPC-24	17.5	24	21	17.5	26.5	21	20.5	16
CD0XXA59C	DC-26.5	QPC-30	17.5	30	21	17.5	26.5	21	20.5	16
CD0XXA86F	DD-22.5	QPD-30	19.125	30	21	19.125	22.5	21	20.5	17.625
CD0XXA89F	DD-22.5	QPD-30	19.125	30	21	19.125	22.5	21	20.5	17.625
CD0XXA52F	DD-26.5	QPD-30	19.125	30	21	19.125	26.5	21	20.5	17.625
CD0XXA56F	DD-26.5	QPD-30	19.125	30	21	19.125	26.5	21	20.5	17.625
CD0XXA59F	DD-26.5	QPD-30	19.125	30	21	19.125	26.5	21	20.5	17.625
CD0XXA565	DE1-26.5	QPE1-30	20.5	30	21	20.5	26.5	21	20.5	19
CD0XXA595	DE1-26.5	QPE1-30	20.5	30	21	20.5	26.5	21	20.5	19
CD0XXA86D	DE-22.5	QPE-30	21	30	21	21	22.5	21	20.5	19.5
CD0XXA56D	DE-26.5	QPE-30	21	30	21	21	26.5	21	20.5	19.5
CD0XXA59D	DE-26.5	QPE-30	21	30	21	21	26.5	21	20.5	19.5
CD0XXA566	DF-26.5	QPF-30	22.75	30	21	22.75	26.5	21	20.5	21.25
CD0XXA596	DF-26.5	QPF-30	22.75	30	21	22.75	26.5	21	20.5	21.25
CD0XXA867	DG-22.5	QPG-30	24.5	30	21	24.5	22.5	21	20.5	23
CD0XXA567	DG-26.5	QPG-30	24.5	30	21	24.5	26.5	21	20.5	23
CD0XXA597	DG-26.5	QPG-30	24.5	30	21	24.5	26.5	21	20.5	23

