

## Horizontal Fan Coil Models:

**HEU1 - DX Cooling w/ Electric Heat, Uncased**  
**HEC1 - DX Cooling w/ Electric Heat, Cased**  
**HEU3 - Chilled Water Cooling w/Electric Heat, Uncased-2P**  
**HEC3 - Chilled Water Cooling w/Electric Heat, Cased-2P**

**HEU2 - DX Cooling w/ Hot Water Heat, Uncased**  
**HEC2 - DX Cooling w/ Hot Water Heat, Cased**  
**HEU4 - Chilled Water Cool w/Hot Water Heat, Uncased-4P**  
**HEC4 - Chilled Water Cooling w/Hot Water Heat, Cased-4P**

## LIST OF SECTIONS

1 – General.....	1	9 – Line Voltage Wiring.....	29
2 – Safety, General, Dimensional Data, Model Number Nomenclature.....	2	10 – Thermostat Wiring and Connections.....	32
3 – Location and Clearances.....	11	11 – Blower Motor Speed Selection and Motor Replacement.....	36
4 – Return and Supply Air Requirements .....	12	12 – Final System Checkout and Startup.....	37
5 – Air Handler Installation .....	14	13 – Blower Performance Tables.....	39
6 – Refrigerant Piping, TXV, Flowrator, Condensate Drain.....	15	14 – Wiring Diagrams.....	43
7 – Hot and Chilled Water.....	21	15 – Minimum Conditioned Space and Air-Flow Tables .....	46
8 – Refrigerant Leak Detection System Operation & Sensor Installation.....	27		

## LIST OF FIGURES

1 – HEC Dimensions - Top View .....	7	20 – Supplemental Heat Lockout (SHL) Temp Switch Wiring.....	20
2 – HEC Dimensions – Side Views.....	8	21 – Typical Condensate Trap.....	20
3 – HEC Dimensions - Rear View .....	8	22 – Condensate Drain Connection Options.....	21
4 – HEC Dimensions – Front View.....	8	23 – Component and Water Components .....	22
5 – HEU Dimensions – Front View.....	9	24 – Refrigerant Leak Detection Sensor Location .....	27
6 – HEU Condensate, Power, Thermostat Connections - Rear View.....	9	25 – Component Locations –Electric Heat Control Box.....	31
7 – HEU Dimensions – Top View.....	10	26 – Component Locations – No Heat Control Box .....	31
8 – HEU Dimensions – Side View .....	10	27 – Component Locations – Hydronic Control Box .....	31
9 – Clearance for Service Access .....	12	28 – Typical Low Voltage Connections – Straight Cooling With Electric or Hydronic Heat .....	33
10 – Ceiling Access Panel.....	13	29 – Typical Low Voltage Connections – Heat Pump With Electric or Hydronic Heat.....	33
11 – Supply and Return Duct Transitions .....	14	30 – Refrigerant Leak Detection System Wiring Connections .....	33
12 – Air Handler Mounting .....	15	31 – Constant Torque Blower Assembly and Blower Deck.....	36
13 – Evaporator Below Outdoor Unit Refrigerant Lines.....	16	32 – Constant Torque Motor Control Module Terminals.....	36
14 – TXV Sensing Bulb Location.....	17	33 – Wiring Diagram - HE*1/HE*3 - No Electric Heat.....	43
15 – TXV Sensing Bulb Placement.....	17	34 – Wiring Diagram - HE*1/HE*3 - Electric Heat.....	43
16 – Typical TXV Connections.....	19	35 – Wiring Diagram - HE*2/HE*4 - No Hydronic Heat .....	44
17 – Flowrator Distributor Assembly.....	19	36 – Wiring Diagram - HE*2/HE*4 - Hydronic Heat With Pump.....	44
18 – Supplemental Heat Lockout (SHL) Temp Sensor Location .....	20	37 – Wiring Diagram - HE*2/HE*4 - Hydronic Heat – No Pump.....	45
19 – Supplemental Heat Lockout (SHL) Temp Sensor Mounting.....	20		

## LIST OF TABLES

1 – HEC1/HEU1/HEC3/HEU General Specifications – Electric Heat.....	7	17 – Wiring Requirements 208/240 VAC HE*1/HE*3**.*BC,CC,DC.....	30
2 – HEC2/HEU2/HEC4/HEU4 General Specifications – Hydronic Heat.....	7	18 – Wiring Requirements 115 VAC HE*2/HE*4**.*AA,AB,AC,AD.....	30
3 – HEC Dimensional Data For Top View .....	7	19 – Electric Heater Heating Capacity Data .....	30
4 – HEC Dimensional Data For Top and Rear Views .....	8	20 – Low Voltage Wire Gauge and Max Lengths.....	32
5 – HEC Rear Knockout Dimensions.....	8	21 – Air Handler Low Voltage Pigtail Wire Colors and Connections .....	34
6 – HEU Dimensional Date for Top View.....	10	22 – Typical Heat/Cool Thermostat Wire Colors and Connections .....	34
7 – HEU/HEC Discharge Opening Dimensions .....	10	23 – Typical Heat Pump Thermostat Wire Colors and Connections.....	34
8 – HEU/HEC Model Number Nomenclature.....	11	24 – Constant Torque Motor Terminals – Electric Heat Models .....	36
9 – Altitude Adjustment Factors .....	11	25 – Constant Torque Motor Terminals – Hydronic Heat Models.....	36
10 – Clearance to Combustibles .....	12	26 – HE*1/HE*3 Blower Performance – CFM .....	39
11 – Optional Ceiling Access Panels.....	13	27 – HE*1/HE*3 Blower Performance – Motor Amps.....	40
12 – HE*2/HE*4***A and HE*2/HE*4***B Hot Water Slab Coil Capacity.....	23	28 – HE*2/HE*4 Blower Performance – CFM .....	41
13 – HE*2/HE*4***B and HE*2/HE*4***C Hot Water Slab Coil Capacity.....	24	29 – HE*2/HE*4 Blower Performance – Motor Amps .....	42
14 – HE*2/HE*4***D Hot Water Slab Coil Capacity .....	25	30 – Min Conditioned Space & Min Airflow - R-454B Refrigerant.....	46
15 – HE*3/HE*4 A-Coil Chilled Water Performance Data .....	26	31 – Min Conditioned Space & Min Airflow - R-32 Refrigerant.....	47
16 – Wiring Requirements 208/240 VAC HE*1/HE*3**.*AC, BC.....	29		

## SECTION 1: GENERAL

The following list includes important facts and information regarding this air handler.

1. This air handler is rated at 208/240 VAC (electric heat) or 115 VAC (hydronic heat), 60 Hertz, Single-Phase.
2. This air handler is not designed to operate at 50 Hertz.
3. Air handler size varies by model.
4. This air handler is designed for both A/C and heat pump applications.
5. Use 4-wire thermostat cable for heating/cooling applications and 7-wire thermostat cable for heat pump applications.
6. This air handler is designed for horizontal applications only.
7. This air handler must not be operated without the access panels installed.
8. This air handler and its components listed are listed by ETL for the United States and Canada.

### WARNING

**This air handler shall only be connected to an outdoor unit suitable for the same refrigerant.**

**This air handler (Model Series HEC and HEU) is a partial unit air conditioner, complying with partial unit requirements of Standard UL 60335-2-40 / CSA C22.2 No. 60335-2-40, and must only be connected to other units that have been confirmed as complying to corresponding partial unit requirements of Standard UL 60335-2-40 / CSA C22.2 No. 60335-2-40.**

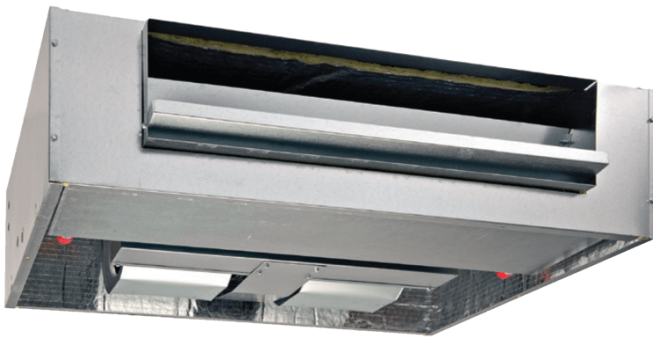

This is a safety alert symbol. When you see this symbol on labels or in manuals, be alert to the potential for personal injury. Understand and pay particular attention to the signal words **DANGER**, **WARNING**, or **CAUTION**.

**DANGER:** Indicates an imminently hazardous situation, which if not avoided, **will result in death or serious injury.**

**WARNING:** Indicates a potentially hazardous situation, which if not avoided, **could result in death or serious injury.**

**CAUTION:** Indicates a **potentially** hazardous situation, which if not avoided, **may result in minor or moderate injury.** It is also used to alert against unsafe practices and hazards involving property damage.

## WARNING

Improper installation may create a condition where the operation of the product could cause personal injury or property damage.

Improper installation, adjustment, alteration, service or maintenance can cause injury or property damage. Refer to this manual for assistance; or for additional information consult a qualified contractor, installer, or service agency.

## WARNING

### FIRE OR ELECTRICAL HAZARD

Failure to follow the safety warnings exactly could result in serious injury, death, or property damage.

A fire or electrical hazard may result causing property damage, personal injury or loss of life.

## CAUTION

This product must be installed in strict compliance with the installation instructions and any applicable local, state, and national codes including, but not limited to; building, electrical, and mechanical codes.

## IMPORTANT

The Clean Air Act of 1990 bans the intentional venting of refrigerant (CFC's and HFC's) as of July 1, 1992. Approved methods of reclaiming must be followed. Fines and/or incarceration may be levied for non-compliance.

## WARNING

### RISK OF FIRE

This unit is equipped with a refrigerant leak detection system for safety and with electrically powered safety measures. To be effective, the unit must be electrically powered at all times after installation, other than when servicing.

## WARNING

### RISK OF FIRE

Refer to Tables 30 and 31 for the minimum floor area of the conditioned space served by this air handler due to the use of an A2L class flammable refrigerant.

## WARNING



### RISK OF FIRE

Do not use means to accelerate the defrosting process or to clean, other than those recommended by the manufacturer.

The appliance shall be stored in a room without continuously operating ignition sources (e.g.: open flames, an operating gas appliance, or an operating electric heater).

Do not pierce or burn.

Be aware that refrigerants may not contain an odor.

## Safety Requirements

1. This air handler must be installed in accordance with all national and local building/safety codes and requirements, local plumbing and waste water codes, and other applicable codes. In the absence of local codes, install in accordance with the following codes.
  - Standard for the Installation of Air Conditioning and Ventilating Systems (NFPA 90A)
  - Standard for the Installation of Warm Air Heating and Air Conditioning Systems (NFPA 90B)
  - National Electrical Code (NFPA 70)
  - Canadian Electrical Code, Part I (CSA C22.2) or ANSI/NFPA No. 70
  - All local codes (State, City, and Township)
- NOTE:** All applicable codes take precedence over any recommendation made in these instructions. Mortex assumes no responsibility for units installed in violation of any code or regulation.
2. Refer to the air handler rating plate for the air handler model number. If a return air plenum is installed on the rear return air knock-out (See Figure 3) instead of using a louvered access panel with filters, the return air plenum must be installed according to the above listed codes or the instructions in this manual.
3. Refer to the dimensions page of these instructions to determine the proper location to install the air handler.
4. This air handler is not ETL listed or approved for installation in a manufactured (mobile) home.
5. Provide clearances from combustible materials as listed in the **LOCATION AND CLEARANCES** section.
6. Provide clearances for service access panel to allow access to the control box, electric heater elements, hot water coil, and blower.
7. Power supply wiring and circuit breakers/fuses must be sized for the electrical characteristics listed on the air handler rating plate.
8. Failure to carefully read and follow all instructions in this manual can result in malfunction of the air handler, death, personal injury, and/or property damage.
9. Electric heat air handlers must be installed so the electrical components are protected from water.
10. Installing and servicing heating/cooling equipment can be hazardous due to electrical components.
11. Only trained and qualified personnel should install, repair, or service heating/cooling equipment. Untrained service personnel only perform basic maintenance functions such as cleaning of exterior surfaces and replacing the air filters.
12. Observe all precautions shown in the manuals and on labels attached to the air handler when servicing or conducting maintenance tasks.
13. These instructions cover minimum requirements and conform to existing national standards and safety codes. In some cases, these instructions exceed certain local codes and ordinances, especially those who have not kept up with changing home construction practices. These instructions are to be followed and are the minimum requirement for a safe installation.
14. The capacity of the heating and cooling system should be based on an acceptable heat loss/heat gain calculation for the structure such as ACCA Manual J or other approved methods.
15. Ground wire connections must be securely fastened to the ground lugs inside the control box.
16. Ductwork must be installed in accordance with the standards of the National Fire Protection Association (NFPA) Warm Air Heating and Ventilation Systems (NFPA Standards 90A and 90B). The air distribution duct should be sized for 0.2 inches of static pressure. See Air Conditioning Contractors of America (ACCA) Manual D for duct sizing.
17. The safety testing label appearing on this air handler covers the air handler and the factory installed coil only. It does not cover any other equipment.
18. Exterior surface of the cabinet may sweat when installed in a non-conditioned space such as an attic or garage. Installer must provide protection for the building structure such as a full size auxiliary drain pan under all air handlers installed in the non-conditioned space. The auxiliary drain pan is needed to prevent building damage from condensation runoff from the unit casing.
19. Cabinet insulation used in this air handler is rated for R-2.1 (standard) and is ½" thick. Some jurisdictions require R-4.2 or R-6.0 on installations in a non-conditioned spaces. Add 1" thick insulation to the exterior casing of the air handler to comply in these jurisdictions and add a vapor barrier on the outside of the added insulation.
20. Air handler must not be operated with the access panels removed.
21. The air handler must be attached to the supporting building structure with screws instead of relying on adhesive.
22. This air handler is for use at elevations of 10,000 ft (3,048m) or less.
23. This air handler is not to be used by persons (including children) with reduced physical, sensory or mental capabilities, or lack of experience and knowledge, unless they have been given supervision or instruction concerning use of this air handler by a person responsible for their safety. Children must not be allowed to play with this air handler.
24. For hydronic heat models, check the rating plate and power supply to be sure that the air handler is connected to a nominal 115 VAC, 1 Phase, 60-Hertz power supply. **DO NOT CONNECT THE AIR HANDLER TO A 50 HZ POWER SUPPLY OR A VOLTAGE ABOVE 127 VOLTS.**
25. For electric heat models, check the rating plate and power supply to be sure that the air handler is connected to a nominal 208/240 VAC, 1 Phase, 60-Hertz power supply. **DO NOT CONNECT THIS AIR HANDLER TO A 50 HZ POWER SUPPLY OR A VOLTAGE ABOVE 250 VOLTS.**
26. 208/240V air handlers are shipped from the factory for 240VAC applications. The transformer must be reconfigured for 208VAC applications using the following steps to assure adequate control voltage (24VAC).
  - a) Remove the zip tie from the transformer wire bundle that secures the BLACK, ORANGE and WHITE wires together.
  - b) Disconnect the WHITE (240VAC) transformer primary wire with an insulated terminal from the load side of the circuit breaker and connect the ORANGE (208VAC) transformer primary wire with an insulated terminal to the same terminal on the circuit breaker.
  - c) Secure the loose BLACK, ORANGE and WHITE wires to the transformer wire bundle with a zip tie.
27. If the main electrical panel supplying electrical power to the air handler utilizes circuit breakers, the circuit breakers must be HACR type.

28. A means of disconnecting all poles of the incoming line voltage power to the air handler must be provided in the fixed field wiring within sight of the air handler unless the air handler is equipped with integral circuit breaker(s) with their ON/OFF lever(s) located on the outside of the air handler which can be used to disconnect line voltage electrical power to the air handler.
29. Ground connections must be securely fastened to the control box and ground wires must be secure.
30. Check that cabling will not be subject to wear, corrosion, excessive pressure, vibration, sharp edges or any other adverse environmental effects. The check shall also take into account the effects of aging or continual vibration from sources such as compressors or fans.
31. Installation, servicing and maintenance must only be performed by qualified service personnel that are licensed by the state to install, service, and repair HVAC equipment and those who have successfully completed a course in handling, installing, commissioning, maintenance, servicing, repairing, decommissioning, and disposing of equipment using a flammable refrigerant offered by an accredited national training organization or the manufacturer of the equipment.
32. Non-duct connected appliances containing A2L refrigerants with the supply and return air openings in the conditioned space may have the body of the appliance installed in open areas such as false ceilings not being used as return air plenums, as long as the conditioned air does not directly communicate with the air of the false ceiling.
33. The use of dropped ceilings for return air is not permitted for this air handler.
34. Safely Commissioning of the System
  - Ensure that the floor area is sufficient for the refrigerant charge or that the ventilation duct is assembled in a correct manner.
  - Connect the pipes and carry out a leak test before charging with refrigerant.
  - Check safety equipment before putting into service.
5. No person carrying out work in relation to a refrigerating system which involves exposing any pipe work shall use any sources of ignition in such a manner that it may lead to the risk of fire or explosion. All possible ignition sources, including cigarette smoking, should be kept sufficiently far away from the site of installation, repairing, removing and disposal, during which refrigerant can possibly be released to the surrounding space. Prior to work taking place, the area around the equipment is to be surveyed to make sure that there are no flammable hazards or ignition risks. "No Smoking" signs shall be displayed.
6. Ensure that the area is in the open or that it is adequately ventilated before breaking into the system or conducting any hot work. A degree of ventilation shall continue during the period that the work is carried out. The ventilation should safely disperse any released refrigerant and preferably expel it externally into the atmosphere.
7. Where electrical components are being changed, they shall be fit for the purpose and to the correct specification. At all times the manufacturer's maintenance and service guidelines shall be followed. If in doubt, consult the manufacturer's technical department for assistance.
8. The following checks shall be applied to installations using flammable refrigerants:
  - the actual refrigerant charge is in accordance with the room size within which the refrigerant containing parts are installed;
  - marking to the equipment continues to be visible and legible. Markings and signs that are illegible shall be corrected;
  - refrigerating pipe or components are installed in a position where they are unlikely to be exposed to any substance which may corrode refrigerant containing components, unless the components are constructed of materials which are inherently resistant to being corroded or are suitably protected against being so corroded.

### **Proper Safe Working Procedures for Equipment Using Flammable Refrigerants**

Prior to beginning work on systems containing flammable refrigerants, safety checks are necessary to ensure that the risk of ignition is minimized. For repair to the refrigerating system, the following steps must be completed prior to conducting work on the system.

1. Work shall be undertaken under a controlled procedure so as to minimize the risk of a flammable gas or vapor being present while the work is being performed.
2. All maintenance staff and others working in the local area shall be instructed on the nature of work being carried out. Work in confined spaces shall be avoided.
3. The area shall be checked with an appropriate refrigerant detector prior to and during work, to ensure the technician is aware of potentially toxic or flammable atmospheres. Ensure that the leak detection equipment being used is suitable for use with all applicable refrigerants, i.e. non-sparking, adequately sealed or intrinsically safe.
4. If any hot work is to be conducted on the refrigerating equipment or any associated parts, appropriate fire extinguishing equipment shall be available to hand. Have a dry powder or CO<sub>2</sub> fire extinguisher adjacent to the charging area.

### **9. Detection of Flammable Refrigerants**

Under no circumstances shall potential sources of ignition be used in the searching for or detection of refrigerant leaks. A halide torch (or any other detector using a naked flame) shall not be used.

The following leak detection methods are deemed acceptable for all refrigerant systems.

Electronic leak detectors may be used to detect refrigerant leaks but, in the case of flammable refrigerants, the sensitivity may not be adequate, or may need re-calibration. (Detection equipment shall be calibrated in a refrigerant-free area.) Ensure that the detector is not a potential source of ignition and is suitable for the refrigerant used. Leak detection equipment shall be set at a percentage of the LFL of the refrigerant and shall be calibrated to the refrigerant employed, and the appropriate percentage of gas (25 % maximum) is confirmed.

Leak detection fluids are also suitable for use with most refrigerants, but the use of detergents containing chlorine shall be avoided as the chlorine may react with the refrigerant and corrode the copper pipe-work.

**NOTE:** Examples of leak detection fluids are:

- bubble method,
- fluorescent method agents.

If a leak is suspected, all naked flames shall be removed/ extinguished.

If a leakage of refrigerant is found which requires brazing, all of the refrigerant shall be recovered from the system, or isolated (by means of shut off valves) in a part of the system remote from the leak. Removal of refrigerant shall be according to Step 10 below.

## 10. Removal and Evacuation

When breaking into the refrigerant circuit to make repairs or for any other purpose, conventional procedures shall be used. However, for flammable refrigerants, it is important that best practice be followed since flammability is a consideration. The following procedure shall be adhered to:

- safely remove refrigerant following local and national regulations;
- evacuate;
- purge the circuit with inert gas (optional for A2L);
- evacuate (optional for A2L);
- continuously flush or purge with inert gas when using flame to open circuit; and
- open the circuit.

The refrigerant charge shall be recovered into the correct recovery cylinders if venting is not allowed by local and national codes. For appliances containing flammable refrigerants, the system shall be purged with oxygen-free nitrogen to render the appliance safe for flammable refrigerants. This process might need to be repeated several times. Compressed air or oxygen shall not be used for purging refrigerant systems.

For appliances containing flammable refrigerants, purging shall be achieved by breaking the vacuum in the system with oxygen-free nitrogen and continuing to fill until the working pressure is achieved, then venting to atmosphere, and finally pulling down to a vacuum (optional for A2L). This process shall be repeated until no refrigerant is within the system (optional for A2L). When the final oxygen-free nitrogen charge is used, the system shall be vented down to atmospheric pressure to enable work to take place.

The outlet for the vacuum pump shall not be close to any potential ignition sources, and ventilation shall be available.

## 11. Charging Procedures

In addition to conventional charging procedures, the following requirements shall be followed.

- Ensure that contamination of different refrigerants does not occur when using charging equipment. Hoses or lines shall be as short as possible to minimize the amount of refrigerant contained in them.
- Cylinders shall be kept in an appropriate position according to the instructions.
- Ensure that the refrigerating system is earthed prior to charging the system with refrigerant.
- Label the system when charging is complete (if not already).
- Extreme care shall be taken not to overfill the refrigerating system.

Prior to recharging the system, it shall be pressure-tested with the appropriate purging gas. The system shall be leak-tested on completion of charging but prior to commissioning. A follow up leak test shall be carried out prior to leaving the site.

## 12. Refrigerant Recovery Requirements

When removing refrigerant from a system, either for servicing or decommissioning, it is recommended good practice that all refrigerants are removed safely.

When transferring refrigerant into cylinders, ensure that only appropriate refrigerant recovery cylinders are employed. Ensure that the correct number of cylinders for holding the total system charge is available. All cylinders to be used are designated for the recovered refrigerant and labeled for that refrigerant (i.e.: special cylinders for the recovery of refrigerant). Cylinders shall be complete with pressure-relief valve and associated shut-off valves in good working order. Empty recovery cylinders are evacuated and, if possible, cooled before recovery occurs.

The recovery equipment shall be in good working order with a set of instructions concerning the equipment that is at hand and shall be suitable for the recovery of the flammable refrigerant. If in doubt, the manufacturer should be consulted. In addition, a set of calibrated weighing scales shall be available and in good working order. Hoses shall be complete with leak-free disconnect couplings and in good condition.

The recovered refrigerant shall be processed according to local legislation in the correct recovery cylinder, and the relevant waste transfer note arranged. Do not mix refrigerants in recovery units and especially not in cylinders.

If compressors or compressor oils are to be removed, ensure that they have been evacuated to an acceptable level to make certain that flammable refrigerant does not remain within the lubricant. The compressor body shall not be heated by an open flame or other ignition sources to accelerate this process. When oil is drained from a system, it shall be carried out safely.

### **WARNING**

**ALWAYS SHUT OFF ELECTRICITY AT THE DISCONNECT SWITCH OR TURN OFF THE CIRCUIT BREAKERS IN THE MAIN ELECTRICAL PANEL BEFORE PREFORMING ANY SERVICE ON THIS AIR HANDLER.**

### **WARNING**

**For air handlers using A2L refrigerants connected via an air duct system to one or more rooms, only auxiliary devices approved by the air handler manufacturer or declared suitable with the refrigerant shall be installed in connecting ductwork.**

## **WARNING**

### **RISK OF FIRE – FLAMMABLE REFRIGERANT APPLICATIONS**

The ductwork connected to this air handler shall not contain an ignition source.

Auxiliary devices which may be a potential ignition source shall not be installed in the duct work. Examples of such potential ignition sources are hot surfaces with a temperature exceeding 1292°F (700°C and electric switching devices.

Only auxiliary devices approved by the air handler manufacturer or declared suitable with the refrigerant shall be installed in connecting ductwork.

Before installing the air handler, check the cabinet for screws or bolts which may have become loose during transit. Some air handler models have shipping supports for the blower motor shaft. Remove this support before operating the air handler unit.

Check the connections of wiring, electric heater, ducts or piping to make sure there is easy access to the air handler during the installation.

## **WARNING**

### **RISK OF FIRE – FLAMMABLE REFRIGERANT APPLICATIONS**

If any refrigerating circuit contains more than 62.6 oz (1.776 kg) of R-454B refrigerant or more than 64.6 oz (1.836 kg) of R-32 refrigerant, an unventilated area where the air handler using a flammable refrigerant is installed shall be so constructed that should any refrigerant leak, it will not stagnate and create a fire or explosion hazard.

If the air duct system connected to one or more rooms with an area less than the 30 and 31 based on the total system refrigerant charge, that room shall be without continuously operating open flames (e.g.: an operating gas appliance) or other potential ignition sources (e.g.: an operating electric heater, hot surfaces). A flame-producing device may be installed in the same space if the device is provided with an effective flame arrest.

### **GENERAL INFORMATION**

This air handler provides the flexibility for installation in any horizontal application and may be used with or without electric heat or hydronic heat. The 5-speed constant torque motor is capable of providing sufficient air flow for most applications. Return air may enter the bottom or end of a cased air handler.

### **Maximum Operating Temperature for Heat Pump Applications**

For heat pump applications, the maximum outdoor temperature recommended by the manufacturer while the system is operating in the heating mode is 70°F/23.9°C.

### **Inspection**

As soon as the air handler is received, it should be inspected for damage that may have occurred during transit. If shipping damage is found, the extent of the damage should be noted on the carrier's freight bill. A separate request for inspection by the carrier's agent should be made in writing. See the local wholesale distributor for more information. Mortex Products, Inc assumes no liability for freight damage.

Model No.	Nominal Cooling Tons	Motor HP	Unit Voltage VAC	Blower Code	CFM Range @ 0.2" ESP	Nominal Heating kW
HE*1/HE*3-**-*-AC	1.5 - 2.0	0.33	208/240	J	482 - 851	00, 03, 05, 06, 08, 10
HE*1/HE*3-**-*-BC	1.5 - 2.5	0.33	208/240	K	480 - 851	00, 03, 05, 06, 08, 10
HE*1/HE*3-**-*-BC	1.5 - 2.5	0.50	208/240	M	837 - 1258	00, 03, 05, 06, 08, 10
HE*1/HE*3-**-*-CC	1.5 - 3.0	0.50	208/240	M	836 - 1267	00, 03, 05, 06, 08, 10
HE*1/HE*3-**-*-DC	1.5 - 3.0	0.50	208/240	M	922 - 1332	00, 03, 05, 06, 08, 10

**Table 1: HEC1/HEU1/HEC3/HEU3 General Specifications – Electric Heat Models**

Model No.	Nominal Cooling Tons	Motor HP	Unit Voltage VAC	Blower Code	CFM Range @ 0.2" ESP
HE*2/HE*4-**-*-AC	1.5 - 2.0	0.33	115	N	485-857
HE*2/HE*4-**-*-BC	1.5 - 2.5	0.33	115	O	486-854
HE*2/HE*4-**-*-BC	1.5 - 2.5	0.50	115	R	834-1253
HE*2/HE*4-**-*-CC	1.5 - 3.0	0.50	115	R	845-1261
HE*2/HE*4-**-*-DC	1.5 - 3.0	0.50	115	R	837-1252

**Table 2: HEC2/HEU2/HEC4/HEU4 General Specifications – Hydronic Heat Models**

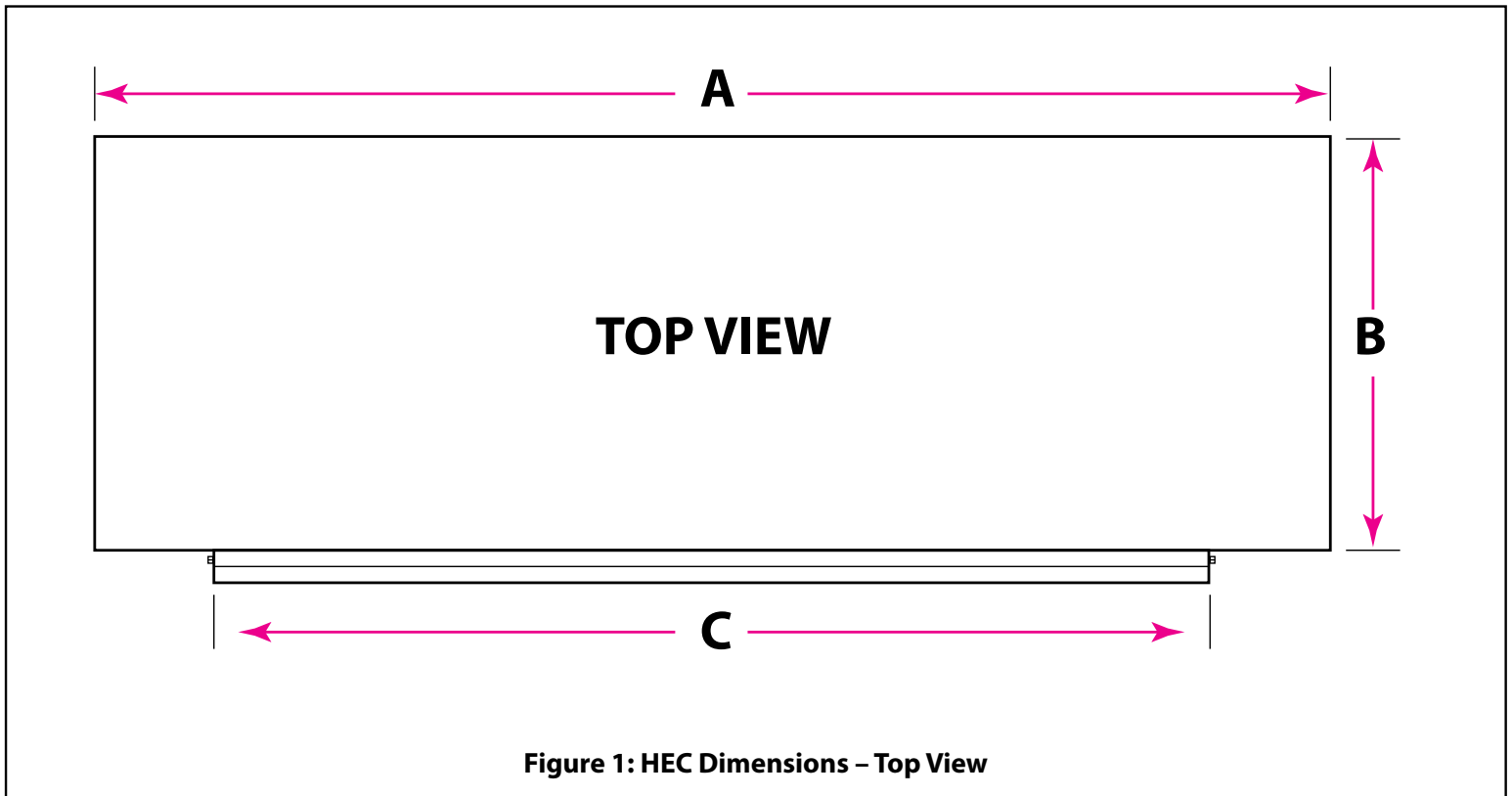

**Figure 1: HEC Dimensions – Top View**

Model No.	LIQUID LINE	SUCTION LINE	WATER LINE	A	B	C
HECX-X-X-X-A	3/8"	3/4"	(2) 5/8"	41"	25 5/8"	30 1/4"
HECX-X-X-X-B	3/8"	3/4"	(2) 5/8"	47"	25 5/8"	38 1/4"
HECX-X-X-X-C	3/8"	3/4"	(2) 5/8"	53 1/2"	25 5/8"	42 1/4"
HECX-X-X-X-D	3/8"	3/4"	(2) 5/8"	60 1/2"	25 5/8"	49 1/4"

**Table 3: HEC Dimensional Data For Top View**

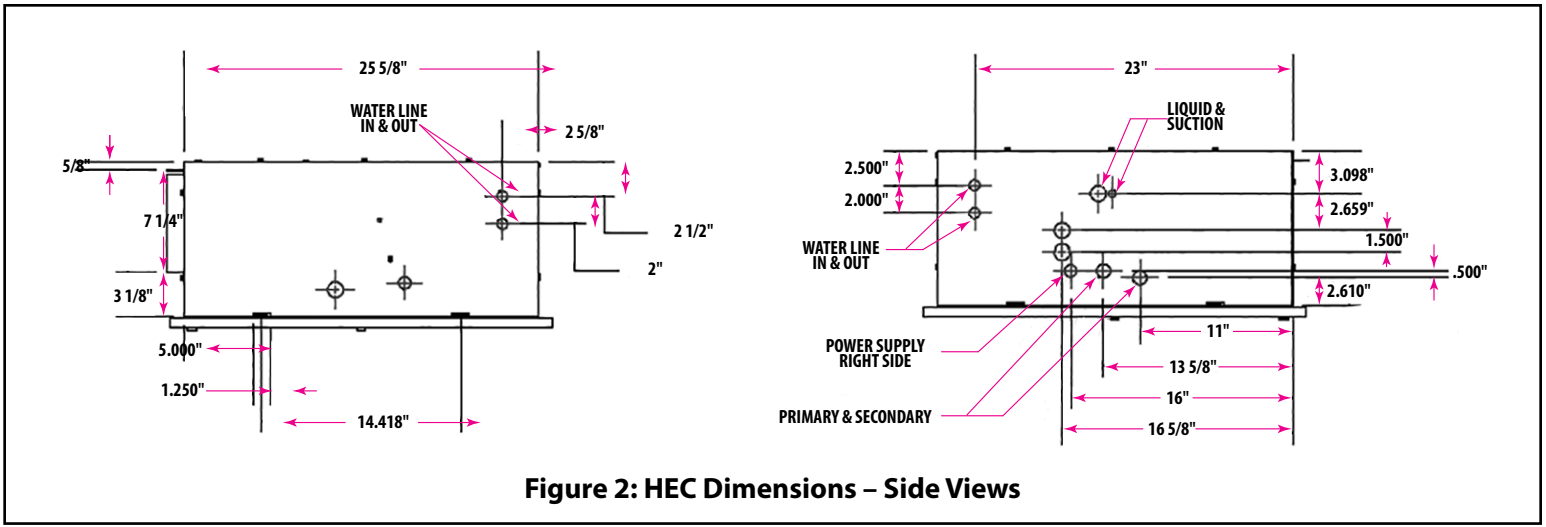

**Figure 2: HEC Dimensions – Side Views**

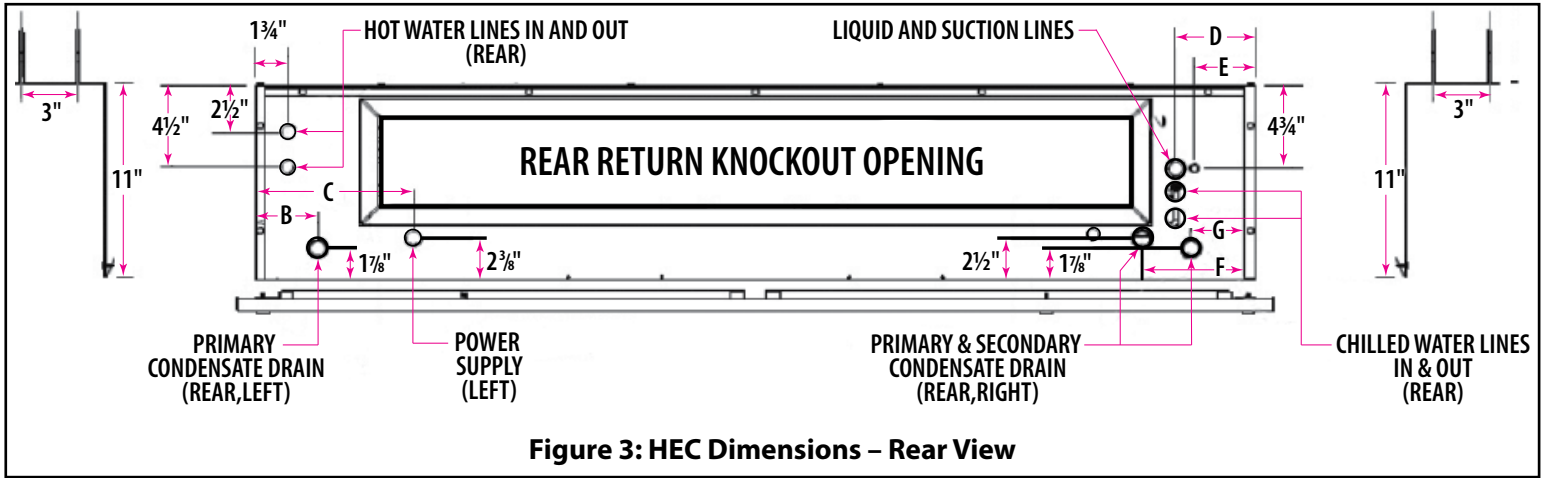

**Figure 3: HEC Dimensions – Rear View**

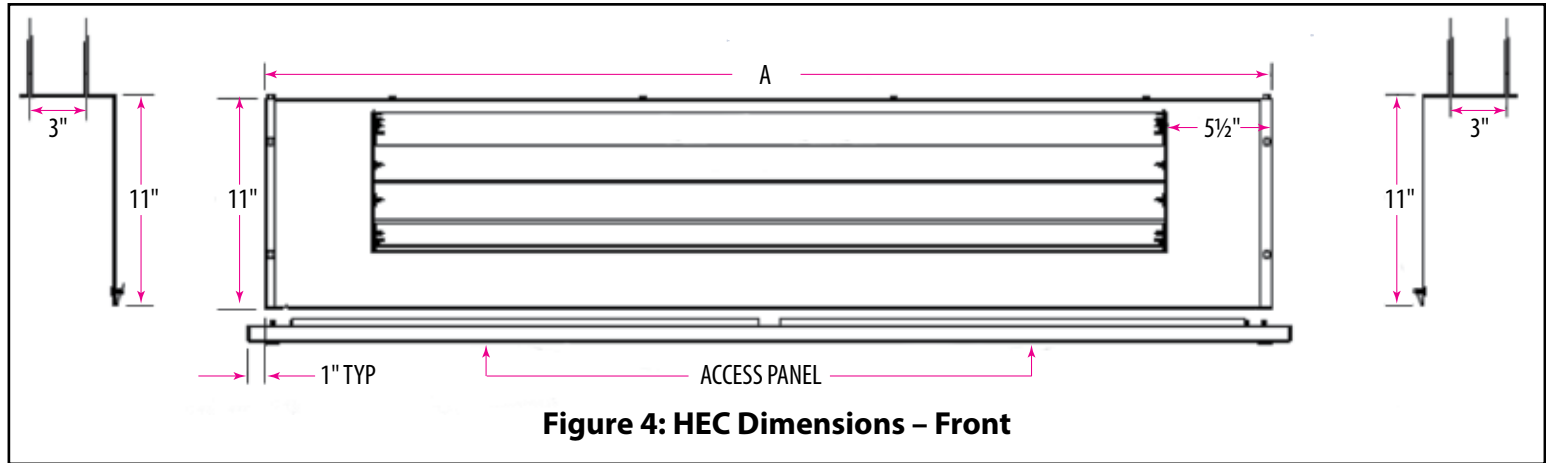

**Figure 4: HEC Dimensions – Front**

Model	A	B	C	D	E	F	G
HEC* - ** - *- AC	41"	3 1/8"	7 5/8"	4"	3"	5 7/8"	3 3/16"
HEC* - ** - *- BC	47"	2 1/8"	6"	3"	2"	4 3/4"	2 1/8"
HEC* - ** - *- CC	53 1/2"	3 1/2"	8 1/2"	4 1/4"	3 1/4"	6"	3 1/2"
HEC* - ** - *- DC	60 1/2"	3 1/2"	12"	4 1/4"	3 1/4"	6"	3 1/2"

**Table 4: HEC Dimensional Data For Front and Rear Views**

Model	Knocket Opening
HEC* - ** - *- AC	<b>30 7/8" X 7 1/4"</b>
HEC* - ** - *- BC	<b>38 3/8" X 7 1/4"</b>
HEC* - ** - *- CC	<b>42 3/8" X 7 1/4"</b>
HEC* - ** - *- DC	<b>49 3/8" X 7 1/4"</b>

**Table 5: HEC Rear Return Knockout Dimensions**

# FRONT VIEW

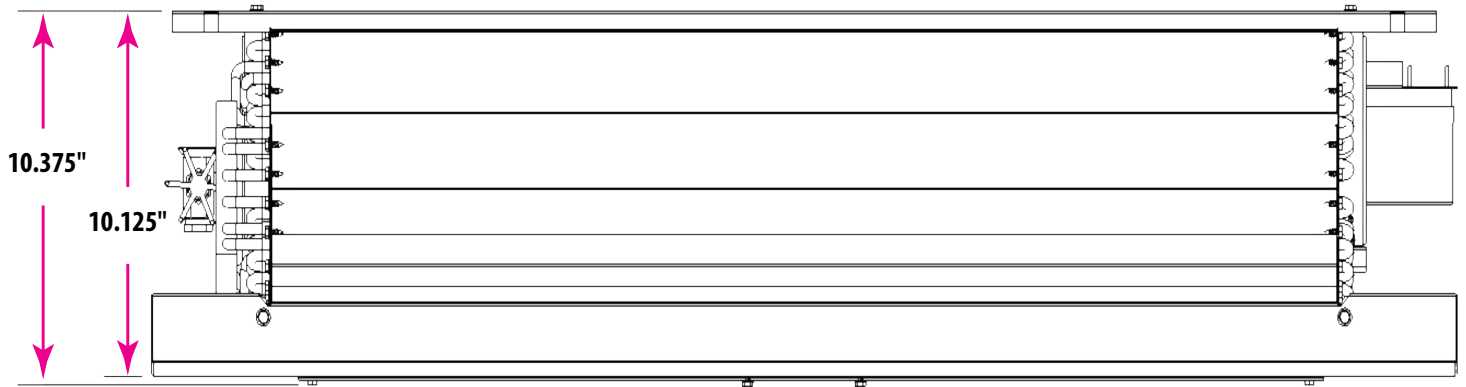

Figure 5: HEU Dimensions - Front View

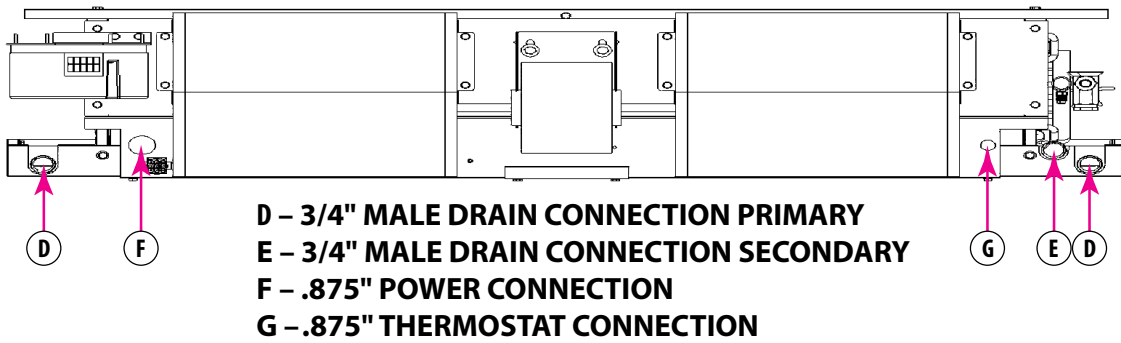
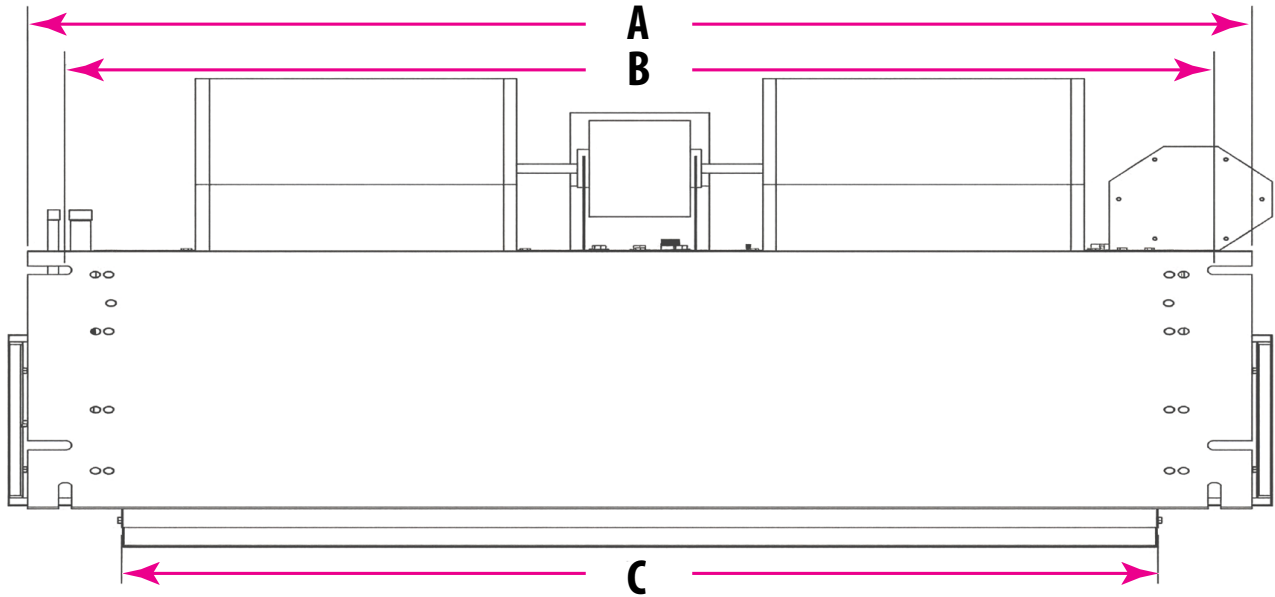

Figure 6: HEU Condensate, Power, Thermostat Connections - Rear View

## TOP VIEW

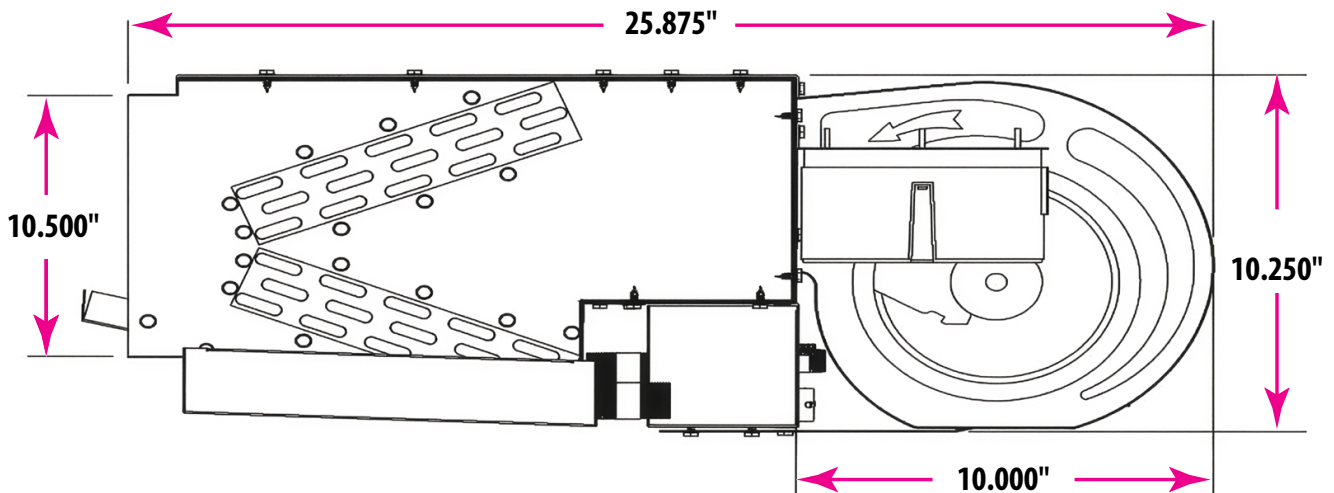

**Figure 7: HEU Dimensions – Top View**

MODEL NUMBER	LIQUID LINE	SUCTION LINE	WATER LINE	A	B	C
HEUX-X-X-X-A	3/8"	3/4"	(2) 5/8"	37	34.25	30
HEUX-X-X-X-B	3/8"	3/4"	(2) 5/8"	45	42.25	38
HEUX-X-X-X-C	3/8"	3/4"	(2) 5/8"	49	46.25	42
HEUX-X-X-X-D	3/8"	3/4"	(2) 5/8"	56	53.25	49

**Table 6: HEU Dimensional Data For Top View**

## SIDE VIEW



**Figure 8: HEU Dimensions – Side View**

Model	Discharge Opening
HEC/HEU*-**-*-AC	30 1/4" X 7 1/2"
HEC/HEU*-**-*-BC	38 1/4" X 7 1/2"

Model	Discharge Opening
HEC/HEU*-**-*-CC	42 1/4" X 7 1/2"
HEC/HEU*-**-*-DC	49 1/4" X 7 1/2"

**Table 7: HEC/HEU Discharge Opening Dimensions**

## "A" Coil Fan Coil Unit Model Nomenclature

HEC 1 - 18 - 1 - 38 C - A K 3 F

<b>Type:</b>	
HEU - Horizontal Fan Coil Unit (Uncased)	
HEC - Horizontal Fan Coil Unit (Cased)	
<b>Series:</b>	
1 - DX Coil and Electric Heat	
2 - DX Coil and Hot Water Heat	
3 - Chilled Water Coil and Electric Heat	
4 - Chilled Water Coil and 2 Row Hot Water Coil	
<b>Cooling Capacity (BTU/H): BTU / TON</b>	
18 - 18,000 BTU / 1.5 Ton Cooling	
24 - 24,000 BTU / 2.0 Ton Cooling	
30 - 30,000 BTU / 2.5 Ton Cooling	
36 - 36,000 BTU / 3.0 Ton Cooling	
<b>"A" Coil Configuration:</b>	
1 - 5/16" Rifled, 3 row, 0.827 x 0.625, 16 FPI, Lanced, 10 Tubes High (DX)	
2 - 5/16" Smooth, 3 row, 0.827 x 0.625, 16 FPI, Lanced, 10 Tubes High (Water)	
3 - 3/8" Rifled, 2 row, 1.00 x 0.625, 16 FPI, Lanced, 8 Tubes High (DX)	
4 - 5/16" Smooth, 2 row, 1.00 x 0.625, 16 FPI, Lanced, 8 Tubes High (Water)	
5 - 3/8" Rifled, 3 row, 1.00 x 0.625, 16 FPI, Lanced, 8 Tubes High (DX)	
6 - 3/8" Smooth, 3 row, 1.00 x 0.625, 16 FPI, Lanced, 8 Tubes High (Water)	
7 - 5/16" Rifled, 2 row, 0.827 x 0.625, 16 FPI, Lanced, 10 Tubes High (DX)	
<b>Fin Length</b>	
A = 30 Inches	
B = 38 Inches	
C = 42 Inches	
D = 49 Inches	

<b>TXV Type:</b>	
D - R410A TXV (1.5 - 2.5 Ton)	
Y - R410A TXV (3.0 Ton)	
F - R32 TXV (1.5 - 3.0 Ton)	
P - R454B TXV (1.5 - 3.0 Ton)	
<b>Heating Capacity</b>	
03 - Electric Heating Capacity	
2N - 2 Row Hot Water Coil No Pump	
2P - 2 Row Hot Water Coil with Pump	
4N - 4 Row Hot Water Coil No Pump	
4P - 4 Row Hot Water Coil with Pump	
<b>Blower Motor and Wheel Package:</b>	
J - 1/3 HP 208/240V, CT Motor w/ (2) 7.00 x 8.00 Blowers. (See NOTE Below)	
K - 1/3 HP 208/240V, CT Motor w/ (2) 7.00 x 9.00 Blowers	
L - 1/2 HP 208/240V, CT Motor w/ (2) 7.00 x 8.00 Blowers	
M - 1/2 HP 208/240V, CT Motor w/ (2) 7.00 x 9.00 Blowers	
N - 1/2 HP 115V, CT Motor w/ (2) 7.00 x 8.00 Blowers	
O - 1/3 HP 115V, CT Motor w/ (2) 7.00 x 9.00 Blowers	
P - 1/2 HP 115V, CT Motor w/ (2) 7.00 x 8.00 Blowers	
R - 1/2 HP 115V, CT Motor w/ (2) 7.00 x 9.00 Blowers	
<b>Blower Motor and Wheel Package</b>	
A - Regal Beloit	
B - Nidec	
<b>Unit Voltage</b>	
A - 115V	
C - 208/240V	
<b>NOTE: "J" Blower Code can only be used on the 30" Fin Length Model</b>	

**Table 8: Model Number Nomenclature**

### SECTION 3: LOCATION AND CLEARANCES

#### **WARNING**

**RISK OF FIRE**

Refer to Tables 30 and 31 for the minimum floor area of the conditioned space served by this air handler due to the use of an A2L class flammable refrigerant.

#### **WARNING**

**RISK OF FIRE – FLAMMABLE REFRIGERANT APPLICATIONS**

If any refrigerating circuit contains more than 62.6 oz (1.776 kg) of R-454B refrigerant or 64.6 (1.836 kg) of R-32 refrigerant, an unventilated area where the air handler using a flammable refrigerant is installed shall be so constructed that should any refrigerant leak, it will not stagnate and create a fire or explosion hazard.

If the air duct system connected to one or more rooms with an area less than the minimum conditioned space floor area shown in Tables 30 and 31 based on the total system refrigerant charge, that room shall be without continuously operating open flames (e.g.: an operating gas appliance) or other potential ignition sources (e.g.: an operating electric heater, hot surfaces). A flame-producing device may be installed in the same space if the device is provided with an effective flame arrest.

When flammable A2L class refrigerants are used, the minimum floor area of the conditioned space the air handler serves must comply with Tables 30 and 31 to allow a refrigerant leak to disperse and be diluted with air to eliminate the risk of the refrigerant igniting and causing an explosion and/or fire. The minimum floor area must be corrected by an altitude adjustment factor based on the building site ground level altitude. See Table 9 for the altitude adjustment factor for various altitudes and refer to the example below for how to apply the altitude adjustment factor.

**Example:**

Total System Charge = 2.6 kg of R-454B  
 Altitude = 2400 m  
 Min. Conditioned Floor Area (MCFA) from Table 30 = 7.97 m<sup>2</sup>  
 Altitude Adjustment Factor (AF) from Table 9 = 1.24  
 Adjusted MCFA = MCFA x AF  
 Adjusted MCFA (@ 2400 m altitude) = 7.97 m<sup>2</sup> x 1.24 = 9.88 m<sup>2</sup>

Altitude Correction Factors									
Altitude (m)	0	100	200	300	400	500	600	700	800
Altitude (ft)	0	328	656	984	1312	1640	1969	2297	2625
AF	1.00	1.01	1.02	1.02	1.03	1.04	1.05	1.06	1.07
Altitude (m)	900	1000	1100	1200	1300	1400	1500	1600	1700
Altitude (ft)	2953	3281	3609	3937	4265	4593	4921	5249	5577
AF	1.08	1.09	1.10	1.11	1.12	1.13	1.14	1.15	1.16
Altitude (m)	1800	1900	2000	2100	2200	2300	2400	2500	2600
Altitude (ft)	5906	6234	6562	6890	7218	7546	7874	8202	8530
AF	1.17	1.18	1.19	1.20	1.21	1.22	1.24	1.25	1.26
Altitude (m)	2700	2800	2900	3000	3100	3200	3400	3600	3700
Altitude (ft)	8858	9186	9514	9842	10171	10499	11155	11811	12139
AF	1.27	1.29	1.30	1.31	1.33	1.34	1.37	1.40	1.42

**Table 9: Altitude Adjustment Factors**

## Location

Access for servicing is an important factor when selecting the location of an air handler. Provide a minimum of 30 inches under the air handler for access to the control box, heating elements, water pump, blower, and air filters. The air handler can be serviced entirely from the bottom, including replacing the air filter on models equipped with a louvered ceiling access panel with an integrated filter rack.

**NOTE:** The air handler is designed for horizontal applications only and is therefore not designed to be installed in a closet or flush mounted in a wall in an upflow vertical position.

Location is usually predetermined. Check with the homeowner or general contractor for predetermined installation plans. If location has not been decided, consider the following in choosing a suitable location.

1. Select a location with adequate structural support, space for service access, and clearance for return and supply duct connections. The air handler is designed to fit in a 12" high drop down space (furred-in area).
2. To assure that the refrigerant leak detection system works properly, the inside dimensions of the furred down area for an **uncased air handler** must be no larger than 12 inches tall x 60 inches wide x 48 inches deep. The furred down area must be completely sealed (with the exception of return air grille) to ensure that return air is being pulled from the conditioned space only. These requirements do not apply to **cased air handlers**.
3. Normal operating sound levels may be objectionable if the air handler is placed directly over or under some rooms such as bedrooms, study, etc.
4. Locate the air handler where the supply and return air ducts can provide even air distribution to and from the living spaces.
5. Locate the air handler where the electrical supply wiring can be easily routed from main electrical panel to the air handler and where electrical wiring will not be damaged.
6. Supply power wiring may be installed in a flexible conduit or armored cable. The installer must refer to National Electrical Code (NFPA 70), Canadian Electrical Code, Part I (CSA C22.2), ANSI/NFPA No. 70 and/or any local codes to ensure supply wiring complies with all applicable codes.
7. Locate appliance where thermostat wiring can be easily routed from the thermostat to the air handler and where the wiring will not be damaged. Make sure the wiring has enough length so it will not block access to any components that may need to be replaced or serviced.
8. Locate the air handler where refrigerant lines can be easily routed from the air handler to the outdoor unit.
9. Primary and secondary drain lines must be routed so air filter replacement is not obstructed.
10. The blow-thru design of this air handler will cause the exterior surface of cabinet to sweat when installed in a non-conditioned space such as an attic or garage. The installer must provide protection such as a full size auxiliary drain pan under any unit installed in a non-conditioned space to prevent damage to the building structure from condensation runoff is a consideration runoff.

## Clearances

This air handler is approved for 0 inches of clearance to combustible material on any part of the air handler exterior casing and the inlet or outlet ducts (See Table 10). A clearance of 30 inches below the air handler is required for the service access panel to swing open (See Figure 9).

Top (inches)	Back (inches)	Sides (inches)	Supply Duct (inches)
0	0	0	0

**Table 10: Clearance to Combustibles**

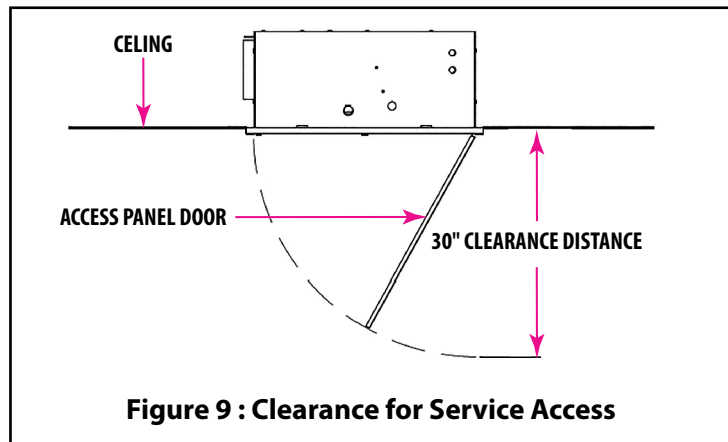

**Figure 9 : Clearance for Service Access**

## SECTION 4: RETURN AND SUPPLY AIR REQUIREMENTS

### RETURN AIR REQUIREMENTS

Provisions shall be made to permit air in the conditioned space to return to the air handler. Failure to provide means for adequate return air will result in reduced airflow through the air handler causing improper heating and cooling of the living space. Reduced airflow may also cause the cooling coil to freeze up and the electric heat limit(s) to cycle, resulting in premature heating element failure.

**NOTE:** Utilizing the space above a dropped ceiling for return air is not permissible for this air handler.

**NOTE:** The return air must be filtered to prevent a buildup of lint, dust, and debris on the coil surface.

**NOTE:** For free return (non-ducted return air) installations, the furred down area must be completely sealed (with the exception of return air grille) to ensure that return air is being pulled from the conditioned space only. o prevent a buildup of lint, dust, and debris on the coil surface.

### Cased Air Handler – Return Air

A cased air handler can utilize a louvered ceiling access panel with an integral filter (See Figure 10) as a means of returning the conditioned air from the conditioned space to the air handler. A cased air handler may also utilize a non-louvered ceiling access panel with a return air duct attached to the return air opening in the air handler. If a return air duct is used, the return air opening knock-out must be removed to allow the return air to enter the air handler through the return air opening. The return air duct may consist of an elbow that drops directly into a return air filter grille in the ceiling or the return duct may be routed between the ceiling joists to a return air filter grille located in the ceiling away from the air handler.

## ⚠️ WARNING

NON-METALLIC RETURN DUCTS MAY NOT BE ALLOWED IN SOME STATES, COUNTIES, OR CITIES.

CHECK ALL STATE, LOCAL AND FIRE CODES TO DETERMINE IF NON-METALLIC RETURN DUCTS ARE ALLOWED.

## ⚠️ WARNING

### FIRE HAZARD:

NON-METALLIC DUCTS CAN COLLECT DUST AND DEBRIS WHICH CAN RESULT IN A FIRE HAZARD. BE SURE TO THOROUGHLY CLEAN THE DUCT SYSTEM ANNUALLY TO REMOVE ALL DUST AND DEBRIS.

### Return Air Filter Location

Horizontal air handlers are not factory equipped with an air filter. The air filter can be installed in the filter rack of the louvered ceiling access panel (See Figure 10 and Table 11) or it may be located remotely in a ceiling mounted return air filter grille. If a return duct and return air filter grille is used, a non-louvered ceiling access panel will be required.

The recommended minimum filter sizes for a return air filter grille is shown below.

Standard Throw-Away Air Filter @ 300 ft/min or Less

600 CFM = 16" x 20" x 1"

700 CFM = 20" x 20" x 1"

800 CFM = 20" x 20" x 1"

900 CFM = 20" x 24" x 1"

1000 CFM = 20" x 24" x 1"

**NOTE:** Pleated filters are not recommended due to their higher pressure drop.

## ⚠️ WARNING

### IMPACT HAZARD

Use extreme caution when removing the ceiling access panel screws. The panel is secured to the frame assembly with the thumb screws. Once the thumb screws have been removed, the ceiling access panel will swing down rapidly and can injure anyone standing underneath the panel. The panel must be supported from underneath as it swings downward to prevent injury.

The louvers can also have sharp edges which can cut hands or fingers. Wearing gloves is recommended when servicing the horizontal air handler.

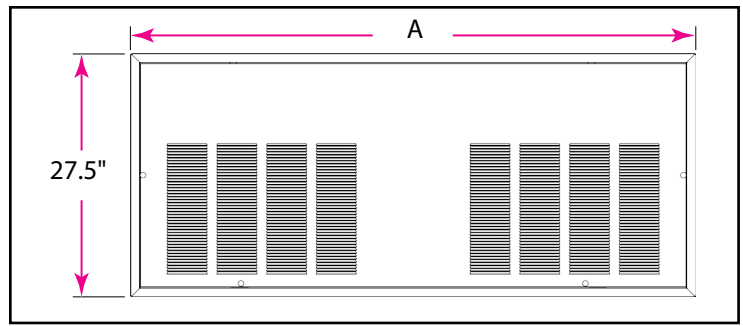

Figure 10: Ceiling Access Panel

PART No.	OVERALL FRAME WIDTH (A in Figure 10)	TYPE	SUNTHERM HORIZONTAL FAN COIL MODELS
HCPL-1	27.5" X 43"	LOUVERED	HE**.**.-A
HCPL-2	27.5" X 49"	LOUVERED	HE**.**.-B
HCPL-3	27.5" X 55.5"	LOUVERED	HE**.**.-C
HCPL-4	27.5" X 62.5"	LOUVERED	HE**.**.-D
CPNL-1	27.5" X 43"	NON-LOUVERED	HE**.**.-A
CPNL-2	27.5" X 49"	NON-LOUVERED	HE**.**.-B
CPNL-3	27.5" X 55.5"	NON-LOUVERED	HE**.**.-C
CPNL-4	27.5" X 62.5"	NON-LOUVERED	HE**.**.-D

Table 11: Optional Ceiling Access Panels

### SUPPLY AIR REQUIREMENTS

horizontal left supply air flow or horizontal right supply air flow. The supply air plenum is attached and secured to the air handler duct flanges using screws. Use a non-tape sealant such as mastic or an aerosol sealant to seal the plenum to the air handler to prevent air leakage. The supply plenum must be the same size as the supply air opening.

The entire supply duct system must be designed for a total of 0.20" W.C. static pressure drop or less and each individual duct must be sized to deliver the proper amount of air to each room of the conditioned space. Holes cut in the supply plenum for ducts must be the same size as the supply ducts. Use a duct starting collar to attach the ducts to the plenum. Use a non-tape sealant such as mastic or an aerosol sealant to seal the ducts to the plenum to prevent air leakage.

If the supply duct system is installed in a non-conditioned space, the duct system must be insulated and installed in accordance with local codes.

**NOTE:** Cased air handlers require return and supply transition ducts to assure proper airflow. Uncased air handlers only require a supply duct transition. See Figure 11 below for factory recommendation.

## ⚠️ IMPORTANT

USING A DUCTED RETURN WILL RESULT IN QUIETER OPERATION THAN USING A LOUVERED CEILING ACCESS PANEL USED FOR RETURN AIR.

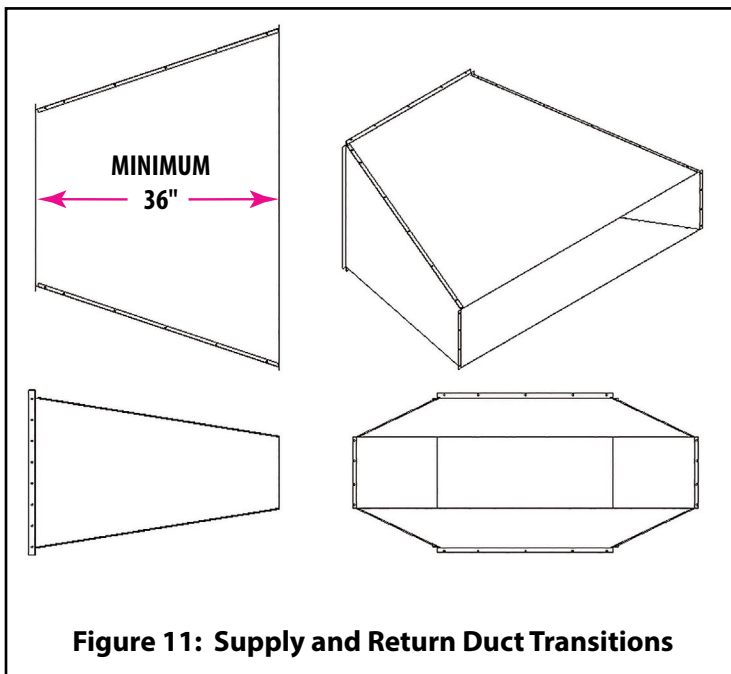

**Figure 11: Supply and Return Duct Transitions**

## WARNING

### RISK OF FIRE – FLAMMABLE REFRIGERANT APPLICATIONS

The following requirements are necessary to allow the flammable refrigerant mitigation system to properly dilute the refrigerant with air in the event of a refrigerant leak.

The supply and return air shall be directly ducted to the space. Open areas such as false ceilings shall not be used as a return air duct.

Keep all supply and return registers for this air handler clear of obstructions.

## SECTION 5: AIR HANDLER INSTALLATION

The area in the ceiling where the air handler is to be located should have a framed in structure so the air handler can be properly mounted and secured. The inside height of the area must be 12 inches. Prior to installing the air handler, holes must be cut into the frame for the refrigerant tubing, drain line(s), electrical wiring, thermostat wiring, and outdoor unit control wiring to enter the air handler. The air handler must be level in both directions to allow proper condensate drainage.

## NOTICE

The air handler and enclosure must be covered during the drywall installation, texturing, and painting process to prevent spray and debris from collecting on and entering the air handler and enclosure.

### Cased Air Handler

The following steps are required to properly install a cased air handler.

1. Remove the top shipping cover and corner posts.
2. Remove the bottom shipping cover.
3. Use screws to secure the 4 straps to the ceiling joists where the air handler will be installed (See Figures 4 and 12). The straps must be located so the hooks in the straps line up with the slots in the base of the air handler.
4. Raise the air handler into place and place the hooks into the slots in the base. Bend the hooks back to keep the hooks from slipping out of the slots in the base.
5. Connect the supply air plenum to the air handler supply air duct flanges as described in **SUPPLY DUCT REQUIREMENTS** found in **SECTION 4** of these instructions.
6. **New Installations Only:**
  - a. If a non-louvered ceiling access panel is being used, connect the return air duct to the air handler as described in **RETURN AIR REQUIREMENTS / Cased Air Handler** found in **SECTION 4** of these instructions.
  - b. After the air handler is mounted, a 2x2 or 2x4 frame must be installed around the base of the air handler to create an air tight seal and support the ceiling access panel frame.
  - c. Install the ceiling access panel.

**NOTE:** The ceiling access panel is sold separately. It is not included with the air handler.

7. Remove the thumb screws that secure the ceiling access panel and slowly swing the panel down.
  8. Remove the control box cover.
  9. Connect the electrical supply wires and the thermostat control wires to the appropriate terminal block and pigtails in the control box as described in **SECTIONS 9 and 10** of these instructions.
- NOTE:** An ON/OFF switch must be installed in the supply circuit to disconnect the power to the air handler during servicing. The identified.

10. Connect the refrigerant lines or chilled water lines to the coil as in **SECTIONS 6 and 7** of these instructions.
11. Make the necessary blower motor speed changes as described in **SECTION 11** of these instructions.
12. Install the control box cover.
13. Raise the ceiling access panel into place and secure with the thumb screws.
14. Turn the power on to the unit by following the procedure found in **SECTION 12** of these instructions and in the **Users Information Manual** to place the air handler into service.
15. Set the thermostat to the desired operating mode and temperature.

## WARNING

### Risk of Fire – Flammable Refrigerant Applications

To assure that the refrigerant leak detection system works properly, the inside dimensions of the furred down area for an **uncased air handler** must be no larger than 12 inches tall x 60 inches wide x 48 inches deep. The furred down area must be completely sealed (with the exception of return air grille) to ensure that return air is being pulled from the conditioned space only. These requirements do not apply to cased air handlers.

# NOTICE

*Extreme caution must be taken that no internal damage will result if screws or holes are drilled into the cabinet.*

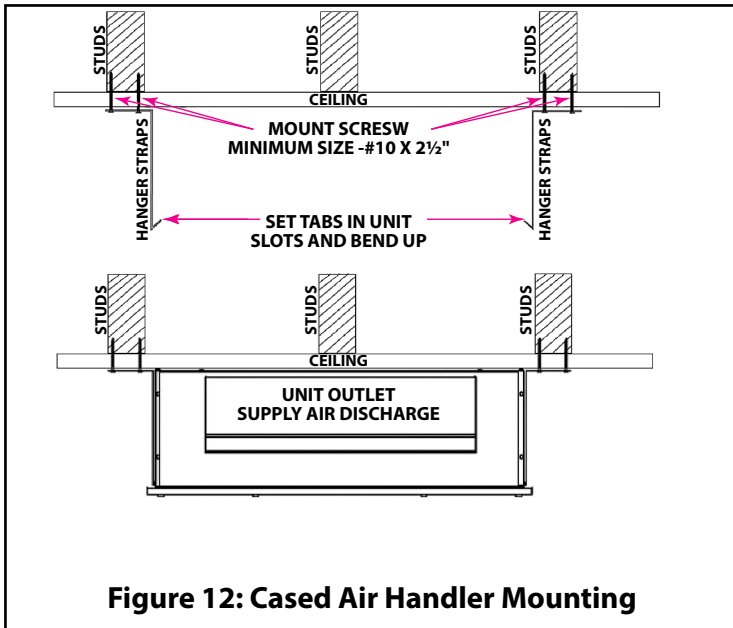

**Figure 12: Cased Air Handler Mounting**

## Uncased Air Handler

**NOTE:** To assure that the refrigerant leak detection system works properly, the inside dimensions of the furred down area for an **uncased air handler** must be no larger than 12 inches tall x 60 inches wide x 48 inches deep. The furred down area must be completely sealed (with the exception of return air grille) to ensure that return air is being pulled from the conditioned space only. These requirements do not apply to **cased air handlers**.

The following steps are required to properly install a cased air handler.

1. Remove the top shipping cover and corner posts.
2. Remove the screws from the control box cover and remove the cover.
3. Remove the bottom shipping cover.
4. Raise the air handler into place and install the lag bolts with washers through the slots in the top cover. Tighten the lag bolts until the air handler is securely fastened to the ceiling.
5. Connect the supply air plenum to the air handler supply air duct flanges as described in **SUPPLY DUCT REQUIREMENTS** found in **SECTION 4** of these instructions.
6. New Installations Only:
  - a. If a non-louvered ceiling access panel is being used, install the return air duct as described in **RETURN AIR REQUIREMENTS / Uncased Air Handler** found in **SECTION 4** of these instructions.
  - b. After the air handler is mounted, a 2x2 or 2x4 frame must be installed around the base of the air handler to create an air tight seal and support the ceiling access panel frame.
  - c. Install the ceiling access panel.

**NOTE:** The ceiling access panel is sold separately. It is not included with the air handler.
7. Remove the thumb screws that secure the ceiling access panel and slowly swing the panel down.
8. Remove the control box cover.

9. Connect the electrical supply wires and the thermostat control wires to the appropriate terminal block and pigtails in the control box as described in **SECTIONS 9 and 10** of these instructions.

**NOTE:** An ON/OFF switch must be installed in the supply circuit to disconnect the power to the air handler during servicing.

10. Connect the refrigerant lines or chilled water lines to the coil as in **SECTIONS 6 and 7** of these instructions.
11. Make the necessary blower motor speed changes as described in **SECTION 11** of these instructions.
12. Install the control box cover.
13. Raise the ceiling access panel into place and secure it with the thumbscrews.
14. Turn the power on to the unit by following the procedure found in **SECTION 12** of these instructions and in the Users Information Manual.
15. Set the thermostat to the desired operating mode and temperature.

## SECTION 6: REFRIGERANT PIPING, TXV, FLOWRATOR, CONDENSATE DRAIN

### DX Refrigerant Piping:

Air handlers with DX type evaporator coils require liquid and suction piping sized in accordance with the outdoor unit manufacturer's instructions. The DX coil has sweat copper connections. Refrigerant lines should be soldered with silver solder or high temperature brazing alloy. The suction line must be insulated to prevent condensate from forming and dripping off. Armaflex (or equivalent) with 3/8" (1 cm) minimum wall thickness is recommended. In severe conditions, such as hot or high humidity areas, insulation with 1/2" (1.3 cm) minimum wall thickness may be required. If the outdoor unit is installed above air handler, oil traps are required at equal intervals along suction line (See Figure 13). Horizontal suction lines should slope downward 1 inch for every 20 feet toward the outdoor unit. Flow dry nitrogen through refrigerant lines during the soldering operation to prevent oxidation of the inside surface of the copper tubing which can result in debris plugging the TXV or orifice screen.

- Install 1 oil trap for a height difference of 15 ft to 25 ft (4.6 m to 7.6 m) between indoor and outdoor units.
- Install 2 oil trap for a height difference of 26 ft to 50 ft (7.9 m to 15.2 m) between indoor and outdoor units.
- Install 3 oil trap for a height difference of 51 ft to 100 ft (15.5 m to 30.5 m) between indoor and outdoor units.
- Install 4 oil trap for a height difference of 101 ft to 150 ft (30.8 m to 45.7 m) between indoor and outdoor units.

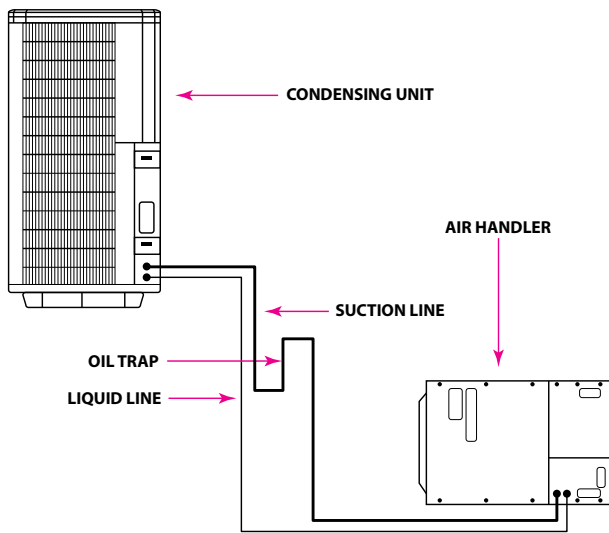

**Figure 13: Piping for Air Handler Below Outdoor Unit**

## **WARNING**

### **RISK OF FIRE**

This following precautions must be taken for the refrigerant piping due to this air handler being used with an A2L class flammable refrigerant.

### **SPECIAL PIPING INSTRUCTIONS DUE TO THE USE OF AN A2L CLASS FLAMMABLE REFRIGERANT**

Piping material, pipe routing, and installation shall include protection from physical damage in operation and service, and shall be in compliance with national and local codes and standards, such as ASHRAE 15, IAPMO Uniform Mechanical Code, ICC International Mechanical Code, or CSA B52. All field joints shall be accessible for inspection prior to being covered or enclosed.

The installation of pipe-work shall be kept to a minimum.

Due to this air handler being used with an A2L class flammable refrigerant, the refrigerant pipe-work shall not be installed in an unventilated space if that space is smaller than the minimum floor area shown in Tables 30 and 31 unless there are no joints in the pipe-work in that space (e.g.: pipework that is run in walls or between floors).

Since refrigerant line length affects the final refrigerant charge, the final refrigerant charge after field charging of the system must be noted and used when determining the minimum floor area of the conditioned space from Tables 30 and 31.

Mechanical connections shall be accessible for maintenance purposes.

For appliances using flammable refrigerants, all joints made in the

installation between parts of the refrigerating system, with at least one part charged, shall be made in accordance with the following:

- A brazed, welded, or mechanical connection shall be made before opening the valves to permit refrigerant to flow between the refrigerating system parts. A vacuum valve shall be provided to evacuate the interconnecting pipe or any uncharged refrigerating part.
- Mechanical connectors used indoors shall comply with ISO 14903 or UL 207 Annex A (USA only). When mechanical connectors are reused indoors, sealing parts shall be renewed. When flared joints are reused indoors, the flare part shall be refabricated.
- Refrigerant tubing shall be protected or enclosed to avoid damage.
- Flexible refrigerant connectors (such as connecting lines between the indoor and outdoor unit) that may be displaced during normal operation shall be protected against mechanical damage.

For installations with field applied joints that are exposed in the occupied space, these joints shall be at least one of the following:

- mechanical joints in compliance with ISO 14903 or UL 207 Annex A (USA only)
- welded or brazed joints; or
- joints in enclosures that vent to the unit or to the outside.

Provision shall be made for expansion and contraction of long runs of piping.

Protection devices, piping, and fittings shall be protected as far as possible against adverse environmental effects, for example, the danger of water collecting and freezing in relief pipes or the accumulation of dirt and debris.

Piping in refrigeration systems shall be so designed and installed to minimize the likelihood of hydraulic shock damaging the system.

After completion of field piping for split systems, the field pipework shall be pressure tested with an inert gas and then vacuum tested prior to refrigerant charging, according to the following requirements:

- The minimum test pressure for the low side of the system shall be the low side design pressure as stated on the air handler rating plate and the minimum test pressure for the high side of the system shall be the high side design pressure as stated on the air handler rating plate, unless the high side of the system cannot be isolated from the low side of the system in which case the entire system shall be pressure tested to the low side design pressure.
- The test pressure after removal of pressure source shall be maintained for at least 1 hour with no decrease of pressure indicated by the test gauge, with test gauge resolution not exceeding 5% of the test pressure.
- During the evacuation test, after achieving a vacuum level specified in the manual or less, the refrigeration system shall be isolated from the vacuum pump and the pressure shall not rise above 1500 microns within 10 min. The vacuum pressure level shall be the lesser of 500 microns or the value required for compliance with national and local codes and standards, which may vary between residential, commercial, and industrial buildings.

Field-made refrigerant joints indoors shall be tightness tested. The test method shall have a sensitivity of 5 grams per year of refrigerant or better under a pressure of at least 0.25 times the maximum allowable pressure. No leak shall be detected.

## SPECIAL INSTRUCTIONS FOR COILS WITH THERMAL EXPANSION VALVES (TXV)

The thermal expansion valve (TXV) used in this air handler has a built-in check valve making it heat pump capable. The external equalizer line attached to the TXV has a female flare nut with built in Schrader valve depressor that attaches to the Schrader valve port located on the coil suction manifold.

A TXV has a thermostatic element separated from the valve body by a diaphragm designed to regulate the rate at which refrigerant flows into the evaporator.

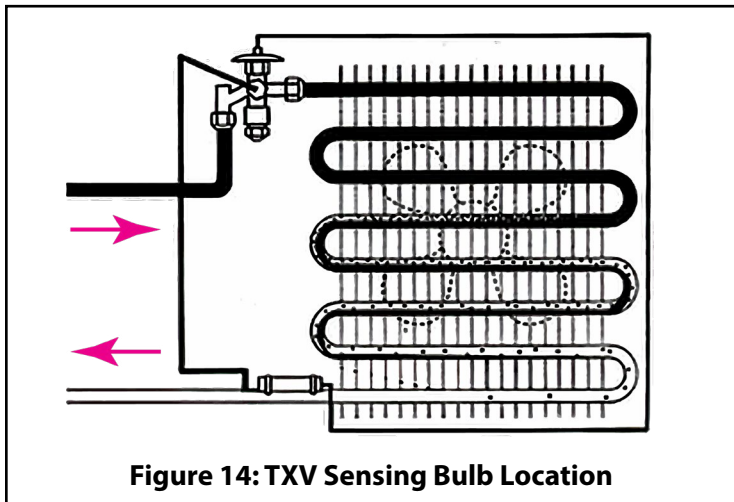

Figure 14: TXV Sensing Bulb Location

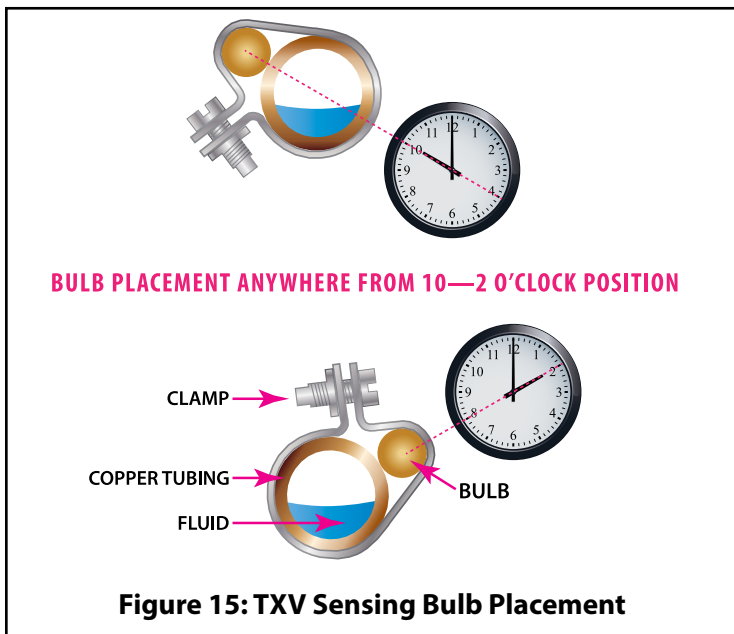

Figure 15: TXV Sensing Bulb Placement

The best location for the TXV sensing bulb is on a horizontal section of the suction line tube and positioned between 10 o'clock and 2 o'clock on the tube. (See Figures 14 and 15).

**NOTE:** The sensing bulb must never be located at the bottom of the suction line due to the possibility of oil and refrigerant laying in the bottom of the pipe causing false signals.

The sensing bulb must be able to sense the temperature of the superheated suction vapor and must therefore not be located in a position that will expose it to extraneous heat/cold. The sensing bulb must be insulated to isolate it from the surrounding air. The TXV must be the proper size and type to achieve the performance ratings of the system.

**NOTE:** If a non-bleed type TXV is used, the outdoor unit may require a hard start kit to allow the compressor to start under load.

### How the TXV Controls Superheat

The TXV is a precision device designed to regulate the rate at which liquid refrigerant flows into the evaporator. This controlled flow is necessary to provide optimum performance and to prevent the return of liquid refrigerant to the compressor.

The TXV separates the high pressure and low-pressure sides of a refrigeration or air conditioning system. Liquid refrigerant enters the TXV under high pressure, but the pressure is reduced when the flow of the refrigerant is restricted by an internal moving pin and port.

It is important to remember that the TXV only controls the level of superheat of the refrigerant in the suction line. The TXV is not designed to control air temperature, head pressure, capacity, suction pressure, or humidity. Attempts to adjust the TXV to control any of these system variables will lead to poor system performance and possible compressor failure.

The TXV responds to the temperature of refrigerant gas as it leaves the evaporator. This temperature is detected by the sensing bulb which is located near the evaporator outlet. The TXV also responds to the refrigerant pressure within the evaporator, which is transmitted to the TXV by an equalizer tube connected to the coil suction manifold. By responding to these variables, the TXV maintains a predetermined superheat level exiting the evaporator which maintains proper system stability, performance, and reliability.

### TXV TROUBLESHOOTING

The thermostatic expansion valve (TXV) is like the carburetor in a car engine. It opens and closes to allow the correct amount of refrigerant flow through the system. When the TXV isn't working properly, the capacity and efficiency of the system is reduced. If a faulty TXV is suspected, perform the following tests:

Connect refrigerant gauges to the system and check that the refrigerant pressures, liquid subcooling and suction superheat levels are correct according to the outdoor unit charging chart. Subcooling at the outdoor unit liquid service valve is normally around 10°F and superheat at the outdoor unit suction service valve is normally between 8-12°F, but these can vary depending on the manufacturer and model of the outdoor unit.

Check to see if the indoor airflow through the system is correct. Check to see if the indoor and outdoor coils and indoor air filters are dirty. Clean dirty coils and clean/replace dirty air-filters as necessary before measuring air-flow and checking pressures, superheat, and subcooling.

Make sure the refrigerant charge in the system is correct. This step may require weighing the refrigerant in the system. Once refrigerant charge weight has been adjusted as necessary, recheck the pressures, subcooling and superheat. If these values are still not correct, the TXV may be defective or the TXV inlet strainer or the liquid line filter dryer is plugged with debris.

A good way to determine if the TXV is defective is to remove the TXV's sensing bulb from the suction line and check the pressures, subcooling, superheat again. No change in the pressures, subcooling, and superheat levels is an indication the TXV is defective. Another test that can be performed is to place the

sensing bulb in ice water and recheck the pressures, superheat, and subcooling levels. If these values don't change, the TXV is likely defective.

### **Additional TXV Troubleshooting Information**

#### **Low Suction Pressure – High Superheat**

##### **POSSIBLE CAUSES:**

1. Undersized TXV
2. TXV superheat adjustment too high
3. High indoor coil pressure drop due to internal restriction
4. TXV sensing bulb installed on bottom of suction line
5. Restricted or capped TXV external equalizer tube
6. Improper TXV external equalizer location (must be located on suction manifold after the last feeder tube)
7. Low refrigerant charge
8. Plugged liquid line filter dryer
9. Plugged TXV inlet strainer
10. Low outdoor ambient temperature

#### **High Suction Pressure – Low Superheat**

##### **POSSIBLE CAUSES:**

11. Oversized TXV
12. TXV seat leakage
13. TXV superheat adjustment too low
14. Improper TXV sensing bulb installation
  - a. Poor thermal contact with suction line (loose clamp)
  - b. Uninsulated sensing bulb
  - c. Warm location
15. Bad compressor (low capacity)
16. Incorrectly located external equalizer line (must be located on suction manifold after the last feeder tube)

#### **Low Suction Pressure – Low Superheat**

##### **POSSIBLE CAUSES:**

1. Low system load:
  - a. Insufficient indoor airflow
  - b. Dirty indoor air filters
  - c. Return air too cold
  - d. Indoor coil icing or frosting
2. Poor air distribution over indoor coil
3. Improper indoor/outdoor coil internal volume balance on heat pump systems (improper air handler/outdoor unit match up; indoor coil too big or too small causing incorrect refrigerant charge balance between cooling and heating modes).
4. Oil trapped in indoor coil

#### **Things to Check Before Replacing TXV**

1. Slowly loosen the flare nut on the TXV external equalizer connected to the suction line port with a flare nut. If there is a large pressure release when the nut has been loosened, tighten the nut. If this results in a slight pressure release or no pressure release, the Schrader valve stem is not being depressed. Install an anti-blow back fitting to the external equalizer line of the TXV to depress the Schrader valve stem and check for proper operation of the TXV.
2. The high side pressure should drop and low side pressure should increase as the TXV opens. Place the sensing bulb in ice water. The high side pressure should increase and the low side pressure should decrease as the TXV closes. If the pressures do not change, TXV is faulty.

#### **FLOWRATOR TO TXV CONVERSION**

While thermal expansion valves can be factory installed, they are normally available in kit form for field installation. Follow the

installation instructions provided with the TXV kit. The TXV must be installed before system is charged with refrigerant. Installation of the TXV requires no cutting or brazing.

**IMPORTANT NOTE:** The flowrator piston must be removed from the flowrator distributor prior to the installation of the TXV (See Figure 17).

#### **Field Installed TXV Kit Information**

**R72DB0101DF:** R-32, 1.5 – 3.0 Ton, 15% Bleed,  
Inlet: Male Rotolock, Outlet: Female Swivel Nut

**R72DB0103DF:** R-454B, 1.5 – 3.0 Ton, 15% Bleed,  
Inlet: Male Rotolock, Outlet: Female Swivel Nut

#### **Field Installed TXV Installation Procedure**



## **WARNING**

**The indoor coil is pressurized with nitrogen. Relieve pressure before installing TXV by depressing Schrader valve on coil suction manifold.**

1. Remove the cap on Schrader valve port on coil suction manifold.
2. Depress the Schrader valve to relieve the pressure inside the coil.
3. Only after coil pressure has been relieved, turn the female swivel nut counter-clockwise to separate it from the distributor.
4. Remove the piston orifice from the flowrator distributor assembly using a small diameter wire or paper clip.
5. As shown in Figure 16, the TXV assembly must be installed between the distributor and the liquid line connector.
6. Attach the TXV by connecting the female swivel nut on TXV outlet to the flowrator distributor (aligning Teflon seal first) and torque swivel nut to 10-30 ft. lbs.
7. Attach the liquid line connector with female swivel nut to male rotolock fitting on TXV inlet (aligning Teflon seal first) and torque swivel nut to 10-30 ft. lbs.
8. Attach equalizer tubing with 1/4" female flare nut that includes depressor to the male Schrader port on the coil suction manifold and torque nut to 10-30 ft. lbs. clamps furnished with kit.
9. Install the TXV bulb to the suction line using the two bulb clamps furnished with kit.
  - a. The sensing bulb should be installed on a horizontal run of the suction line if possible and should be positioned between 10 o'clock and 2 o'clock as shown in Figure 15.
  - b. If the sensing bulb is installed on a vertical run of the suction line, the bulb should be located at least 6 inches away from any bend and on the side of the tube that is above the inside of the bend. On vertical run bulb installations, the bulb should be positioned with the bulb capillary tube at the top.
  - c. The bulb should be insulated using thermal insulation to protect it from the effect of the surrounding ambient temperature.
10. After completing the TXV installation, leak check all TXV fittings and thoroughly evacuate the coil through the service access valves prior to charging the system with refrigerant.

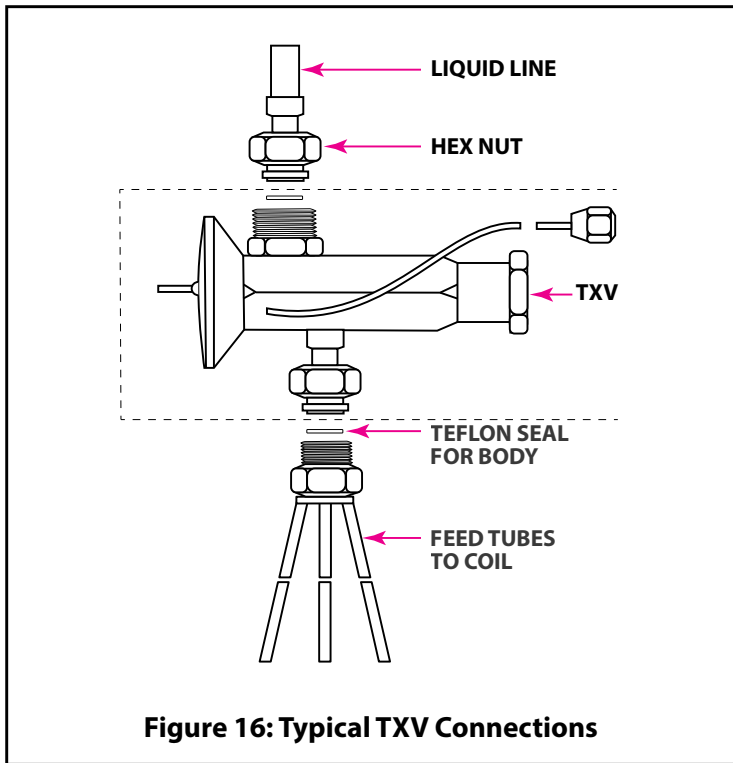

**Figure 16: Typical TXV Connections**

**SPECIAL INSTRUCTIONS FOR COILS WITH FLOWRATOR DISTRIBUTOR ASSEMBLIES**

The sizing of the orifice piston should be based on the rated capacity of the outdoor unit and air handler match-up.

Summit provides capacity performance ratings that match both same size and upsized air handlers with specific manufacturer's outdoor units. Consult the local Summit distributor for the proper size orifice piston to be used for a specific outdoor unit model number. The factory installed orifice piston size is marked on the flowrator distributor assembly and the air handler carton.

Failure to install the proper size orifice piston can lead to poor system performance and possible compressor damage. A variation of one piston size smaller or larger is not normally critical. Mortex/Summit reserves the right to substitute a factory installed piston one size smaller or greater if the piston size ordered is out of stock. A selection of replacement orifice pistons is available from the local Summit distributor.

**ORIFICE PISTON REPLACEMENT**

If the flowrator is being used instead of a TXV, the piston must be installed oriented as shown in Figure 17 in the distributor body and the existing liquid line attached to the flowrator distributor.

1. Remove the cap on Schrader valve port on coil manifold.
2. Depress the Schrader valve to relieve the pressure inside the coil.
3. Only after coil pressure has been relieved, turn the female swivel nut counter-clockwise to separate it from the distributor.
4. Replace the orifice piston with the correct size piston for the application. Make sure the tapered end of the piston is facing the feeder tubes on the distributor body.
5. Turn the female swivel nut clockwise on the flowrator 10-30 ft. lbs.
6. After completing the installation of the correct size orifice piston, leak check the flowrator distributor fitting and thoroughly evacuate the system through the service fittings on the outdoor unit liquid and suction service valves.

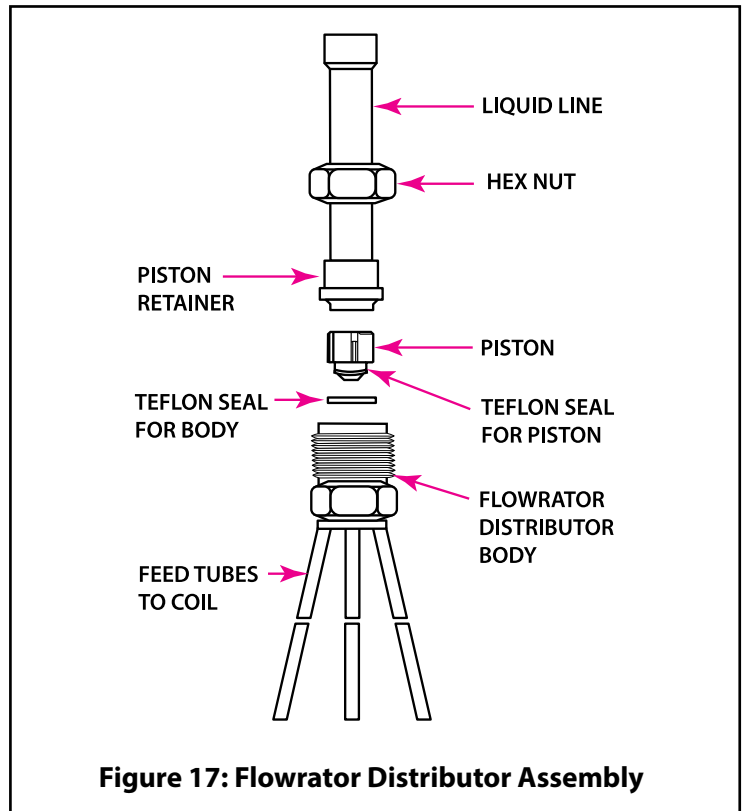

**Figure 17: Flowrator Distributor Assembly**

A field installed supplemental heat lockout (SHL) kit must be used with SEHX and CEHX models equipped with electric heat when used in a heat pump system. The purpose of the SHL is to prevent excessive refrigerant pressures due to the indoor coil being located downstream of the electric heating elements. If the electric heater is energized while the heat pump is operating in the heat mode, the additional heat imparted to the indoor coil by the electric heater elements can cause the refrigerant pressures to be excessively high. The SHL temperature switch contacts will open and lock out the electric heat when the hot gas line temperature entering the indoor coil reaches approximately 120°F. The contacts will close when the hot gas line temperature falls to approximately 109°F which will allow the electric heat to operate.

**Installation of the SHL Kit**

After brazing and leak testing of the refrigerant lines is completed and the lines have sufficiently cooled, mount the SHL temperature sensor securely to the suction/hot gas refrigerant line that connects to the coil manifold (larger line; suction in cooling mode; hot gas in heating mode) with the 2 plastic wire ties provided in the kit assuring that the temperature switch has good contact with the refrigerant line and is not located where it may be damaged. Wrap the sensor on the refrigerant line using the insulation tape provided in the kit and secure with the insulation with the 2 plastic wire ties provided in the kit (See Figure 19).

**SHL Switch Wiring:**

One of the SHL switch pigtail leads is connected to the air handler white pigtail wire with a wire nut (See Figure 20). The other SHL switch pigtail lead is connected to the white thermostat wire from the thermostat W terminal and secured with a wire nut. Check the outdoor unit and thermostat wiring diagrams to assure the SHL will prevent the supplemental electric heat from being energized when the switch contacts are open.

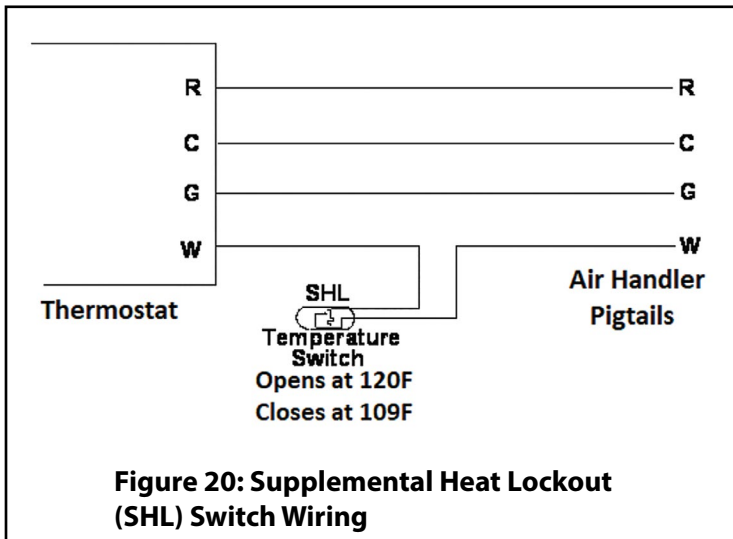
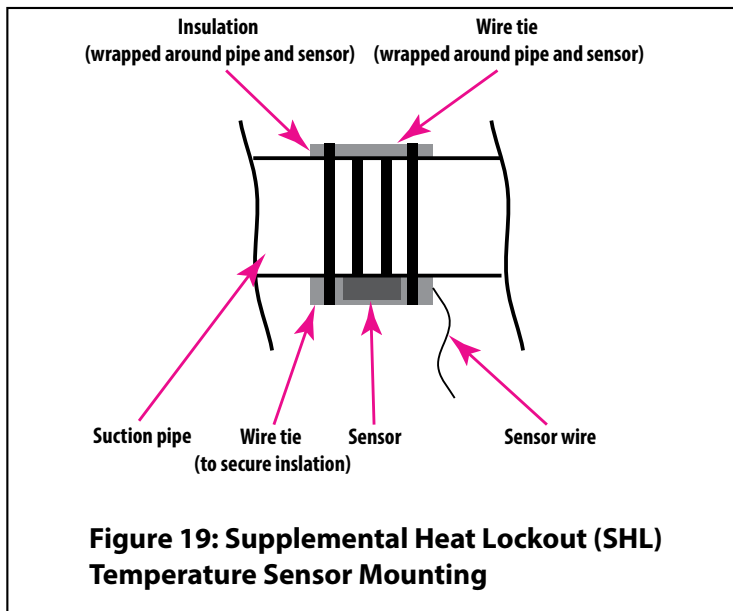
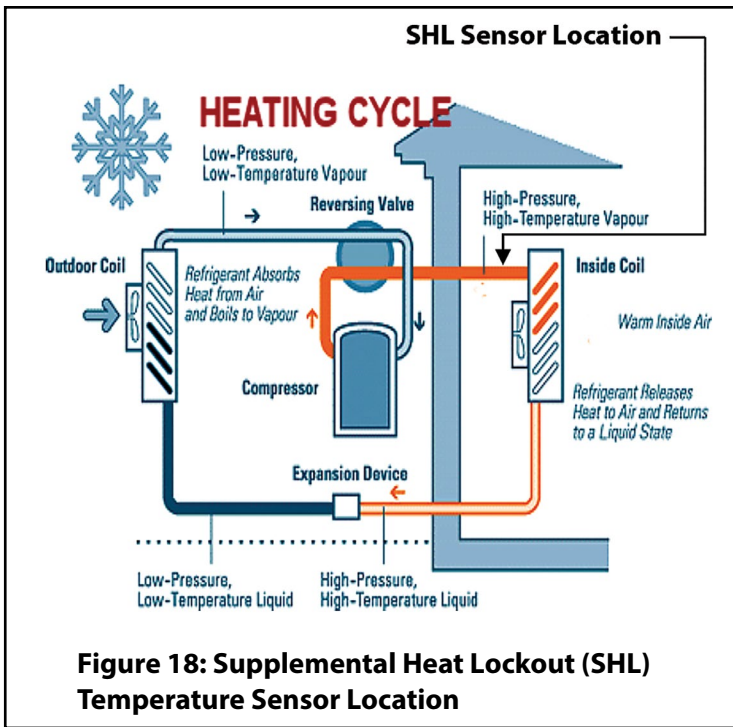

**CONDENSATE DRAIN PIPING**

The blow-through DX coil design of this air handler will create positive pressure in the condensate drain system. To prevent air from being blown out of the primary condensate drain line, it is recommended that a minimum 2-inch trap with an anti-siphon air vent be installed as shown in Figure 21. Piping from the condensate drain connection must have adequate slope for drainage to a visible area. Do not pipe the condensate drains from two different air handlers into one common drain. Cap any unused condensate drain pan connections.

**NOTE:** A condensate trap may be required by local codes. Installing a trapped secondary drain line is also recommended to prevent condensate pan overflow should the primary drain become clogged. A secondary drain float switch that will shut the cooling system off should the primary drain become clogged may be installed instead of a secondary drain line.

**NOTE:** Do not pipe the primary and secondary drains together. If the secondary drain is not used, it must be capped.

The air handler cooling DX coil condensate drain pan has one 3/4" NPT female primary and one 3/4" NPT female secondary connection located on the same side as the refrigerant line connections (See Figure 22). The other side of the condensate drain pan has one 3/4" NPT female primary drain connection and no secondary drain connection.

**NOTE:** The condensate drain connections are located on the condensate drain pan inside the cabinet of a cased air handler. Condensate drain piping must enter through the holes in the cabinet and then connect to the drain pan connections within the cabinet. Refer to Figures 2, 3, and 6 for condensate drain pipe connections and entrances.

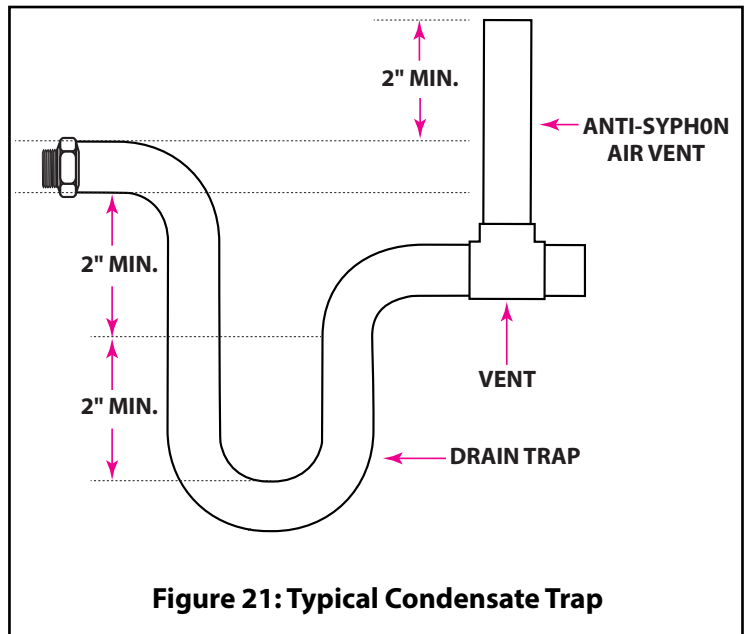

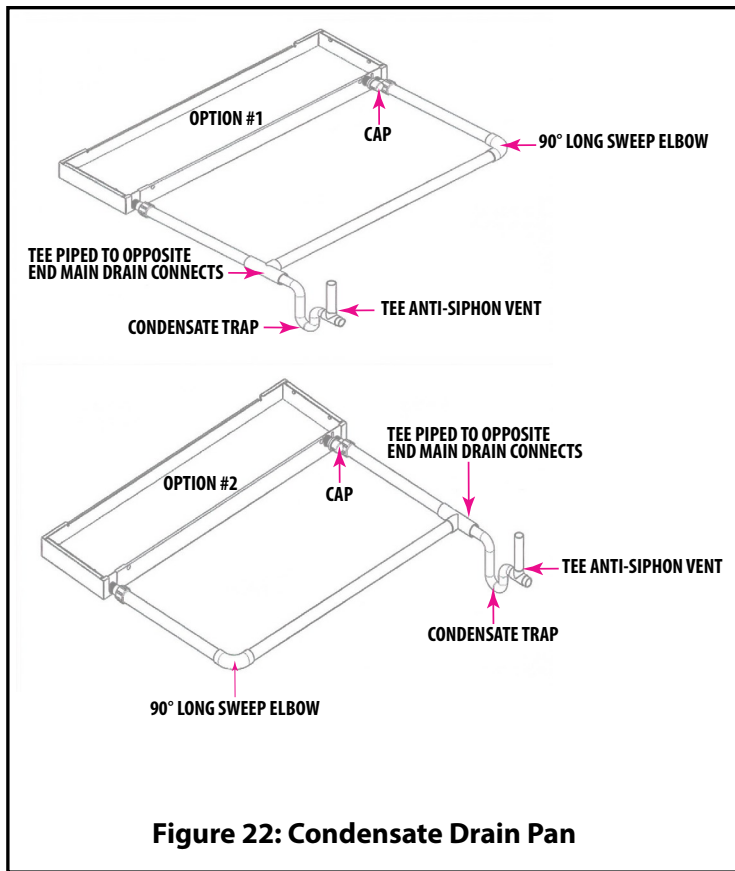

**Figure 22: Condensate Drain Pan**

## ⚠️ WARNING

This air handler must not be located where water can cause damage to the adjacent area if the condensate drain pan should overflow or if any condensate drain connections should leak.

When such locations can't be avoided, a suitable auxiliary drain pan must be installed under the air handler and connected to an adequate drain. The auxiliary drain pan should be at least 2" greater in length and width than the air handler dimensions and should be at least 1.5" deep.

The manufacturer of this air handler is not liable for any water damage related to the air handler.

## SECTION 7: HOT AND CHILLED WATER

### Hot Water Piping

All water piping must be supported independent of the air handler to prevent vibration and stress on the coil headers. Swing joints or flexible fittings must be provided to absorb expansion and contraction of the piping. Rigid piping reduces the effectiveness of vibration isolators. Water pipes must be adequately vented in order to prevent air binding. The air handler is equipped with manual air vents mounted on the coil manifold.

Total hot water piping length should not exceed 140 feet. All hot water piping to the coil should be 3/4 inch ID (7/8 inch OD) copper. CPVC and PEX piping may also be used in applications where the water temperature does not exceed 150°F. It is recommended a water isolation valve and a union be placed in the water lines to and from the coil, near the coil, for serviceability, repair or replacement

of the coil. A thermal expansion tank is recommended on any closed loop system to relieve thermal expansion due to pressure increase.

After piping has been installed, allow the system to fill with water and check connections for leaks. To ensure complete filling of the system, follow the Filling Hydronic Heating System With Water, Purging Air From System, and System Startup procedure found in **SECTION 11: Final System Checkout and Startup** in these instructions.

**NOTE:** These models are capable of using the chilled water coil for hot water heat as well as chilled water cooling using a valve on the hot water line and a valve on the chilled water line to isolate the hot water from the chilled water.

**CAUTION:** Never operate air handler with hot water heat and electric heat energized at the same time.

**IMPORTANT NOTE:** Massachusetts state code 780 CMR 61.00 requires an electronically controlled pump timer that activates the pump every 6 hours for 60 seconds and limits the distance between the water heater and the air handler to 50 feet maximum.

## ⚠️ WARNING

Toxic chemicals used for treatment of boilers or non-potable water heating appliances shall never be introduced into a potable water space heating system.

## ⚠️ WARNING

Hot water from a boiler used to satisfy heating requirements can be heated to temperatures of 180°F. Parts containing water this hot can scald very quickly. Use extreme caution when servicing or performing maintenance on any parts containing hot water.

## ⚠️ WARNING

Minimum Allowable Operating Temperatures – Water/Brine:  
 Water = 36°F (2.22°C)  
 Brine Solution = 3.2°F (-16°C)  
 Maximum Allowable Operating Temperatures – Water/Brine:  
 Water = 180°F (82.22°C)  
 Brine Solution = 40°F (4.44°C)

## ⚠️ WARNING

When system requires water at temperatures higher than required for other uses, a means such as a mixing valve must be installed to temper the water temperature for those uses in order to reduce the potential of a scald hazard.

## ⚠️ WARNING

Do not use Methanol water or Ethanol in any systems operating above 40°F as the flash point specified for these chemicals is only 54°F.

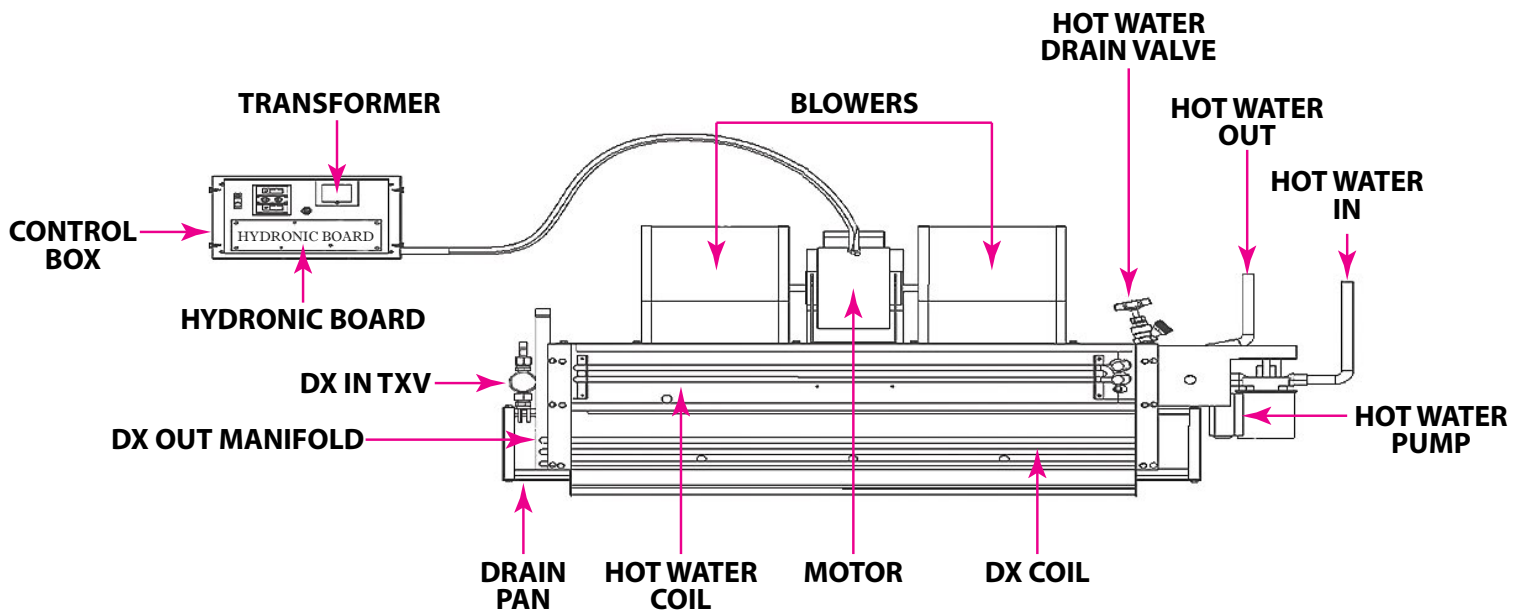

**Figure 23: Components and Water Connections**

**Performance Data - Hot Water Slab Coils**  
**HEATING PERFORMANCE DATA:**

HOT WATER SLAB-COIL MODEL	HOT WATER CAPACITIES @70°F ENTERING AIR TEMPERATURE ENTERING WATER TEMPERATURE										CFM	GPM	PRESS. DROP WATER (FT-WTR)	PRESS. DROP AIR (IW C)
	100°F	110°F	120°F	130°F	140°F	150°F	160°F	170°F	180°F					
HE*2***A HE*4***A	6,516	8,735	10,974	13,228	15,496	17,777	20,067	23,367	24,674	480	2.0	0.78	0.10	
	6,987	9,357	11,742	14,141	16,550	18,970	21,399	23,835	26,277		3.0*	1.61		
	7,253	9,706	12,174	14,651	17,138	19,634	22,137	24,647	27,162		4.0	2.68		
	7,425	9,932	12,450	14,979	17,515	20,059	22,609	25,165	27,726		5.0	3.97		
	7,547	10,090	12,644	15,208	17,779	20,356	22,938	25,526	28,118		6.0	5.49		
	7,280	9,682	12,170	14,677	17,201	19,740	22,293	24,856	27,428	590	2.0	0.78	0.15	
	7,812	10,467	13,141	15,832	18,537	21,255	23,984	26,722	29,469		3.0*	1.61		
	8,152	10,914	13,694	16,487	19,292	22,108	24,935	27,768	30,610		4.0	2.68		
	8,374	11,205	14,052	16,911	19,780	22,659	25,547	28,441	31,342		5.0	3.97		
	8,531	11,410	14,304	17,209	20,123	23,045	25,976	28,912	31,854		6.0	5.49		
	7,791	10,456	13,147	15,862	18,597	21,349	24,116	26,897	29,689	695	2.0	0.78	0.20	
	8,497	11,390	14,305	17,240	20,193	23,160	26,141	29,133	32,134		3.0*	1.61		
	8,906	11,929	14,371	18,030	21,105	24,192	27,291	30,400	33,517		4.0	2.68		
	9,175	12,281	15,406	18,546	21,698	24,862	28,036	31,219	34,410		5.0	3.97		
	9,366	12,531	15,714	18,910	22,117	25,334	28,561	31,795	35,036		6.0	5.49		
	8,291	11,131	14,002	16,899	19,819	22,758	25,714	28,686	31,670	800	2.0	0.78	0.25	
	9,105	12,208	15,339	18,491	21,664	24,854	28,060	31,278	34,508		3.0*	1.61		
	9,581	12,837	16,115	19,413	22,730	26,061	29,405	32,761	36,127		4.0	2.68		
	9,895	13,250	16,626	20,018	23,427	26,849	30,282	33,726	37,179		5.0	3.97		
	10,120	13,544	16,988	20,448	23,921	27,406	30,902	34,402	37,920		6.0	5.49		
8,508	11,425	14,373	17,350	20,350	23,371	26,410	29,465	32,533	850	2.0	0.78	0.28		
9,372	12,568	15,792	19,041	22,311	25,599	28,904	32,222	35,552		3.0*	1.61			
9,878	13,238	16,621	20,025	23,448	26,887	30,340	33,806	37,282		4.0	2.68			
10,215	13,680	17,167	20,672	24,194	27,730	31,280	34,839	38,409		5.0	3.97			
10,455	13,995	17,555	21,132	24,723	28,328	31,944	35,570	39,204		6.0	5.49			
HE*2***A HE*4***A	7,165	9,597	10,046	14,509	16,984	19,470	21,965	24,468	26,977	480	2.0	0.96	0.06	
	7,665	10,258	12,863	15,481	18,109	20,746	23,390	26,040	28,696		3.0*	1.96		
	7,943	10,624	13,316	16,018	18,728	21,446	24,170	26,900	29,635		4.0	3.27		
	8,122	10,858	13,604	16,360	19,122	21,891	24,665	27,445	30,228		5.0	4.86		
	8,247	11,021	13,805	16,597	19,396	22,200	25,009	27,822	30,639		6.0	6.71		
	7,974	10,686	13,419	16,170	18,935	21,715	24,505	27,304	30,113	590	2.0	0.96	0.09	
	8,614	11,532	14,467	17,418	20,381	23,356	26,340	29,332	32,332		3.0*	1.96		
	8,974	12,008	15,055	18,116	21,188	24,269	27,359	30,456	33,559		4.0	3.27		
	9,208	12,314	15,434	18,564	21,705	24,854	28,010	31,173	34,340		5.0	4.86		
	9,372	12,529	15,698	18,878	22,066	25,261	28,463	31,671	34,884		6.0	6.71		
	8,637	11,579	14,545	17,533	20,538	23,559	26,593	29,638	32,693	695	2.0	0.96	0.12	
	9,406	12,596	15,808	19,037	22,283	25,542	28,812	32,092	35,980		3.0*	1.96		
	9,845	13,176	16,525	19,890	23,268	26,658	30,058	33,467	36,883		4.0	3.27		
	10,130	13,552	16,990	20,441	23,904	27,377	30,859	34,350	37,847		5.0	4.86		
	10,332	13,816	17,316	20,827	24,349	27,881	31,420	34,967	38,519		6.0	6.71		
	9,217	12,361	15,533	18,728	21,944	25,178	28,426	31,688	34,960	800	2.0	0.96	0.16	
	10,110	13,544	17,002	20,482	23,979	27,492	31,019	34,556	38,104		3.0*	1.96		
	10,626	14,226	17,846	21,485	25,140	28,809	32,489	36,180	39,879		4.0	3.27		
	10,964	14,672	18,397	22,138	25,894	29,662	33,441	37,229	40,024		5.0	4.86		
	11,203	14,985	18,785	22,599	26,425	30,262	34,109	37,965	41,827		6.0	6.71		
9,469	12,701	15,962	19,249	22,557	25,883	29,225	32,581	35,948	850	2.0	0.96	0.18		
10,420	13,961	17,528	21,118	24,726	28,351	31,991	35,643	39,304		3.0*	1.96			
10,972	14,690	18,432	22,192	25,970	29,763	33,568	37,384	41,208		4.0	3.27			
11,334	15,169	19,022	22,893	26,780	30,679	34,590	38,511	42,440		5.0	4.86			
11,592	15,507	19,440	23,389	27,351	31,325	35,310	39,303	43,304		6.0	6.71			

**Note: "3\*" = Optional factory installed hot water circulating pump flow rate.**

**Table 12: HE\*2/HE\*4\*\*\*A and HE\*2/HE\*4\*\*\*B Hot Water Slab Coil Capacity**

**Performance Data - Hot Water Slab Coils**  
**HEATING PERFORMANCE DATA:**

HOT WATER SLAB-COIL MODEL	HOT WATER CAPACITIES @ 70°F ENTERING AIR TEMPERATURE ENTERING WATER TEMPERATURE										CFM	GPM	PRESS. DROP WATER (FT-WTR)	PRESS. DROP AIR (IW C)
	100°F	110°F	120°F	130°F	140°F	150°F	160°F	170°F	180°F					
<b>HE*2***A</b> <b>HE*4***A</b>	9,217	12,361	15,533	18,728	21,944	25,178	28,246	31,688	34,960	800	2.0	0.96	0.16	
	10,110	13,544	17,002	20,482	23,979	27,492	31,019	34,556	38,104		3.0*	1.96		
	10,626	14,226	17,846	21,485	25,140	28,809	32,489	36,180	39,879		4.0	3.27		
	10,964	14,672	18,397	22,138	25,894	29,662	33,441	37,229	40,024		5.0	4.86		
	11,203	14,985	18,785	22,599	26,425	30,262	34,109	37,965	41,827		6.0	6.71		
	9,754	13,086	16,448	19,837	23,249	26,681	30,129	33,592	37,067	910	2.0	0.96	0.20	
	10,773	14,436	18,127	21,842	25,578	29,331	33,099	36,880	40,673		3.0*	1.96		
	11,368	15,222	19,101	23,001	26,919	30,854	34,802	38,761	42,730		4.0	3.27		
	11,759	15,739	19,770	23,759	27,996	31,847	35,909	39,482	44,064		5.0	4.86		
	12,038	16,105	20,193	24,296	28,415	32,547	36,690	40,842	45,002		6.0	6.71		
	10,212	13,704	17,299	20,784	24,364	27,965	31,585	35,220	38,868	1,015	2.0	0.96	0.24	
	11,345	15,207	19,100	23,020	26,962	30,923	34,903	38,896	42,901		3.0*	1.96		
	12,014	16,091	20,195	24,323	28,472	32,639	36,820	41,015	45,221		4.0	3.27		
	12,455	16,675	20,917	25,181	29,464	33,763	38,075	42,399	46,733		5.0	4.86		
	12,771	17,090	21,431	25,791	30,167	34,559	38,962	43,376	47,800		6.0	6.71		
	10,645	14,288	17,968	21,680	25,418	29,180	32,962	36,760	40,574	1,125	2.0	0.96	0.29	
	11,893	15,946	20,032	24,147	28,288	32,449	36,630	40,827	45,037		3.0*	1.96		
	12,636	16,928	21,250	25,599	29,970	34,361	38,769	43,192	47,626		4.0	3.27		
	13,129	17,580	22,057	26,559	31,080	35,620	40,175	44,743	49,323		5.0	4.86		
	13,483	18,047	22,634	27,243	31,871	36,515	41,173	45,843	50,523		6.0	6.71		
11,020	14,795	18,608	22,456	26,333	30,324	34,157	38,098	42,054	1,230	2.0	0.96	0.34		
12,394	16,593	20,849	25,137	29,452	33,790	38,148	42,524	46,914		3.0	1.96			
13,185	17,666	22,181	26,726	31,294	35,884	40,493	45,117	49,754		4.0	3.27			
13,727	18,383	23,069	27,781	32,515	37,270	42,041	46,825	51,623		5.0	4.86			
14,116	18,898	23,705	28,536	33,388	38,257	43,142	48,040	52,950		6.0	6.71			
<b>HE*2***A</b> <b>HE*4***A</b>	9,607	12,879	16,177	19,498	22,838	26,195	29,566	32,949	36,341	800	2.0	1.04	0.13	
	10,535	14,109	17,706	21,322	24,957	28,605	32,267	35,939	39,621		3.0*	2.14		
	11,069	14,814	18,579	22,362	26,160	29,971	33,793	37,625	41,465		4.0	3.57		
	11,417	15,273	19,146	23,036	26,939	30,853	34,777	38,710	42,651		5.0	5.30		
	11,662	15,596	19,546	23,510	27,485	31,472	35,467	39,470	43,480		6.0	7.32		
	10,177	13,647	17,146	20,671	24,217	27,782	31,363	34,956	38,561	910	2.0	1.04	0.17	
	11,238	15,055	18,897	22,763	26,648	30,551	34,467	38,396	42,375		3.0*	2.14		
	11,856	15,870	19,908	23,967	28,044	32,135	36,239	40,554	44,478		4.0	3.57		
	12,260	16,405	20,570	24,753	28,952	33,165	37,389	41,622	45,865		5.0	5.30		
	12,547	16,783	21,037	25,308	29,592	33,889	38,197	45,513	46,837		6.0	7.32		
	10,633	14,301	17,973	21,672	25,395	29,138	32,899	36,673	40,460	1,015	2.0	1.04	0.20	
	11,847	15,873	19,929	24,011	28,115	32,237	36,376	40,527	44,690		3.0*	2.14		
	12,542	16,792	21,069	25,370	29,690	34,027	38,377	42,741	47,114		4.0	3.57		
	13,000	17,398	21,819	26,261	30,720	35,195	39,683	44,182	48,690		5.0	5.30		
	13,326	17,828	22,351	26,892	31,450	36,021	40,604	45,198	49,800		6.0	7.32		
	11,122	14,921	18,755	22,619	26,510	30,421	34,352	38,299	42,258	1,125	2.0	1.04	0.24	
	12,429	16,658	20,918	25,207	29,521	33,854	38,205	42,571	46,949		3.0*	2.14		
	13,203	17,682	22,190	26,724	31,279	35,853	40,443	45,047	49,622		4.0	3.57		
	13,716	18,360	23,030	27,723	32,436	37,166	41,910	46,667	51,434		5.0	5.30		
	14,083	18,844	23,629	28,434	33,257	38,096	42,948	47,812	52,685		6.0	7.32		
11,520	15,458	19,433	23,441	27,477	31,536	35,614	39,710	43,819	1,230	2.0	1.04	0.28		
12,940	17,345	21,786	26,258	30,755	35,275	39,813	44,368	48,937		3.0*	2.14			
13,788	18,468	23,180	27,921	32,685	37,469	42,271	47,088	51,918		4.0	3.57			
14,353	19,215	24,106	29,022	33,960	38,917	43,890	48,876	53,874		5.0	5.30			
14,757	19,749	24,767	29,808	34,868	39,947	45,039	50,144	55,260		6.0	7.32			

**Note: "3\*" = Optional factory installed hot water circulating pump flow rate.**

**Table 13: HE\*2/HE\*4\*\*\*B and HE\*2/HE\*4\*\*\*C Hot Water Slab Coil Capacity**

**Performance Data - Hot Water Slab Coils**

HEATING PERFORMANCE DATA:

HOT WATER SLAB-COIL MODEL	HOT WATER CAPACITIES @ 70°F ENTERING AIR TEMPERATURE ENTERING WATER TEMPERATURE										CFM	GPM	PRESS. DROP WATER (FT-W TR)	PRESS. DROP AIR (IW C)
	100°F	110°F	120°F	130°F	140°F	150°F	160°F	170°F	180°F					
<b>HE*2***A HE*4***A</b>	10,205	13,671	17,162	20,674	24,204	27,748	31,305	34,873	38,448	800	2.0	1.20	0.10	
	11,188	14,975	18,784	22,612	26,455	30,313	34,181	38,058	41,944		3.0*	2.46		
	11,749	15,717	19,704	23,707	27,723	31,755	35,794	39,842	43,898		4.0	4.09		
	12,112	16,197	20,298	24,414	28,543	32,682	36,830	40,985	45,148		5.0	6.07		
	12,368	16,534	20,716	24,909	29,115	33,330	37,553	41,783	46,019		6.0	8.39		
	10,824	14,505	18,213	21,945	25,697	29,465	33,248	37,042	40,844	910	2.0	1.20	0.12	
	11,954	16,005	20,281	24,178	28,294	32,424	36,567	40,721	44,884		3.0*	2.46		
	12,607	16,868	21,152	25,454	29,773	34,106	38,450	42,804	43,166		4.0	4.09		
	13,032	17,430	21,848	26,282	30,732	35,194	39,666	44,147	48,636		5.0	6.07		
	13,332	17,827	22,338	26,865	31,405	35,957	40,518	45,087	49,663		6.0	8.39		
	11,353	15,217	19,111	23,031	26,973	30,933	34,908	38,895	42,893	1,015	2.0	1.20	0.15	
	12,619	16,898	21,206	25,537	29,888	34,257	38,640	43,034	47,439		3.0*	2.46		
	13,356	17,874	22,418	26,983	31,566	36,164	40,776	45,398	50,030		4.0	4.09		
	13,840	18,514	23,211	27,926	32,658	37,404	42,163	46,931	51,707		5.0	6.07		
	14,183	18,967	23,771	28,592	33,429	38,278	43,138	48,007	52,884		6.0	8.39		
	11,853	15,890	19,960	24,058	28,179	32,321	36,479	40,650	44,832	1,125	2.0	1.20	0.18	
	13,255	17,754	22,284	26,840	31,418	36,015	40,628	45,254	49,891		3.0*	2.46		
	14,080	18,846	23,641	28,459	33,298	38,154	43,025	47,908	52,801		4.0	4.09		
	14,624	19,566	24,534	29,523	34,530	39,553	44,589	49,637	54,694		5.0	6.07		
	15,011	20,078	25,167	30,275	35,401	40,541	45,693	50,856	56,026		6.0	8.39		
12,286	16,474	20,697	24,949	29,227	33,526	37,842	42,173	46,515	1,230	2.0	1.20	0.21		
13,814	18,506	23,231	27,985	32,763	37,561	42,377	47,206	52,048		3.0*	2.46			
14,719	19,707	24,724	29,767	34,833	39,912	45,017	50,131	55,246		4.0	4.09			
15,321	20,502	25,710	30,943	36,195	41,465	46,749	52,046	57,353		5.0	6.07			
15,750	21,069	26,412	31,778	37,162	42,361	47,975	53,400	58,834		6.0	8.39			

**Note: "3\*" = Optional factory installed hot water circulating pump flow rate.**

**Table 14: HE\*2/HE\*4\*\*D Hot Water Slab Coil Capacity**

## Chilled Water Piping

Supply and return chilled water piping to the coil should be 3/4 inch ID for models with a capacity up to 42,000 BTU/H and 1 inch on models with a capacity greater than 42,000 BTU/H. Water piping must always be connected so that the entering water is on the leaving side of the coil for best performance.

<b>Performance Data - Firdown Chilled Water A-Coils</b>																								
<b>COOLING PERFORMANCE DATA:</b>																								
<b>CHILLED WATER A-COIL MODEL</b>	<b>Rows</b>	<b>Circuits</b>	<b>45°F Entering Water</b>									<b>42°F Entering Water</b>												
			<b>GPM</b>	<b>PRESS. DROP WATER</b>			<b>80°F DB / 67°F W B</b>			<b>75°F DB / 63°F W B</b>			<b>GPM</b>	<b>PRESS. DROP WATER</b>			<b>80°F DB / 67°F W B</b>			<b>75°F DB / 63°F W B</b>			<b>CFM</b>	<b>PRESS. DROP AIR</b>
				<b>(FT-WTR)</b>	<b>TH</b>	<b>SH</b>	<b>TR</b>	<b>TH</b>	<b>SH</b>	<b>TR</b>	<b>(FT-WTR)</b>	<b>TH</b>		<b>SH</b>	<b>TR</b>	<b>TH</b>	<b>SH</b>	<b>TR</b>	<b>(IN-W C)</b>					
HE*3/HE*4CC4A	2	4	3.8	4.55	20,469	14,267	10.0	16,406	12,503	8.6	4.4	5.89	23,828	15,709	10.0	19,375	13,946	8.8	480	0.06				
HE*3/HE*4CC4A	2	4	4.4	5.89	23,750	16,745	10.0	18,984	14,798	8.6	5.2	7.92	27,813	18,498	10.0	22,578	16,356	8.7	590	0.10				
HE*3/HE*4CC4A	2	4	5.2	7.92	26,870	19,260	10.0	21,719	17,901	8.3	5.6	9.04	30,625	20,846	10.0	25,000	18,580	8.9	695	0.12				
HE*3/HE*4CC4A	2	4	5.6	9.04	29,375	21,377	10.0	23,594	19,059	8.4	6.2	10.82	33,750	23,179	10.0	27,578	20,604	8.9	800	0.15				
HEC3/HEC4CC6A	3	6	6.8	6.21	36,563	25,436	10.0	29,219	22,292	8.6	7.8	7.92	42,188	27,723	10.0	34,453	24,865	8.8	850	0.27				
HE*3/HE*4CC4B	2	4	4.4	7.06	22,891	15,213	10.0	18,242	13,432	8.3	5.0	8.85	26,250	16,831	10.0	21,250	14,889	8.5	480	0.05				
HE*3/HE*4CC4B	2	4	5.0	8.85	26,484	17,956	10.0	21,094	15,785	8.4	5.6	10.82	30,391	19,732	10.0	24,688	17,561	8.8	590	0.07				
HE*3/HE*4CC6B	3	6	7.0	7.83	35,078	23,155	10.0	29,496	19,847	8.4	7.6	9.06	39,688	25,281	10.0	32,221	22,210	8.5	695	0.09				
HE*3/HE*4CC6B	3	6	7.0	7.83	38,164	25,501	10.0	30,469	22,517	8.7	8.4	10.82	44,219	28,214	10.0	35,938	24,958	8.6	800	0.14				
HE3/HEC4CC6B	3	6	8.4	10.82	41,406	27,634	10.0	32,866	24,180	7.8	8.8	11.75	46,446	29,937	10.0	37,752	26,482	8.6	850	0.17				
HE*3/HE*4CC6B	3	6	7.8	9.49	40,174	26,875	10.0	31,953	23,480	8.2	8.6	11.28	45,781	29,421	10.0	37,109	26,026	8.6	800	0.18				
HE*3/HE*4CC6B	3	8	8.0	4.42	42,344	28,869	10.0	33,750	25,661	8.4	8.8	5.24	48,128	31,435	10.0	39,375	28,227	8.9	910	0.20				
HE*3/HE*4CC6B	3	8	8.8	5.24	45,428	31,511	10.0	36,324	27,660	8.3	9.6	6.11	51,680	33,962	10.0	42,266	30,461	8.9	1015	0.24				
HE*3/HE*4CC6B	3	8	9.8	6.34	49,375	34,324	10.0	39,434	30,081	8.0	10.4	7.04	55,625	37,023	10.0	45,508	33,167	8.7	1125	0.28				
HE3/HEC4CC6B	3	8	10.4	7.04	52,188	36,333	10.0	41,719	32,157	8.0	10.8	7.53	58,750	39,256	10.0	48,047	35,080	8.9	1230	0.34				
HE*3/HE*4CC6C	3	8	8.0	4.79	40,469	26,930	10.0	32,205	23,812	8.0	8.4	5.23	45,469	29,198	10.0	37,031	26,079	8.8	800	0.15				
HE*3/HE*4CC6C	3	8	8.8	5.68	44,492	30,078	10.0	35,313	26,238	8.0	9.2	6.14	50,000	32,318	10.0	40,781	28,798	8.9	910	0.16				
HE*3/HE*4CC6C	3	8	9.2	6.14	47,985	32,560	10.0	38,125	28,624	8.3	10.0	7.12	54,531	35,780	10.0	44,355	31,487	8.9	1015	0.19				
HE*3/HE*4CC6C	3	8	10.0	7.12	51,250	35,136	10.0	41,094	31,232	8.2	10.8	8.16	58,281	38,259	10.0	47,500	33,965	8.8	1125	0.22				
HE*3/HE*4CC6C	3	8	10.8	8.16	54,844	38,043	10.0	43,750	33,393	8.8	11.4	8.98	61,875	41,002	10.0	50,469	36,352	8.8	1230	0.27				
HE*3/HE*4CC6D	3	8	9.8	7.79	46,642	30,638	10.0	37,018	26,887	7.8	10.4	8.66	52,500	33,452	10.0	42,648	29,388	8.2	800	0.13				
HE*3/HE*4CC6D	3	8	10.4	8.66	50,020	33,095	10.0	39,688	28,984	7.6	10.8	9.26	56,016	35,803	10.0	45,563	31,711	8.4	910	0.15				
HE*3/HE*4CC6D	3	8	11.0	9.56	54,078	36,190	10.0	42,969	31,601	7.8	11.4	10.19	60,781	39,216	10.0	49,375	34,647	8.7	1015	0.19				
HE*3/HE*4CC6D	3	8	11.4	10.19	57,792	39,923	10.0	45,898	34,314	8.0	12.0	11.16	65,097	42,271	10.0	53,047	37,668	8.8	1125	0.21				
HE*3/HE*4CC6D	3	8	12.0	11.16	60,625	41,205	10.0	48,438	36,279	8.1	12.6	12.16	68,438	44,788	10.0	55,849	39,414	8.9	1230	0.23				

**TH - Total Heat    SH - Sensible Heat    TR - Water Temperature Rise**

**Table 15: HE\*3/HE\*4 A-Coil Chilled Water Performance Data**

## WARNING

This air handler is equipped with a refrigerant leak mitigation system that energizes the air handler blower motor to deliver at least the required minimum airflow (See Tables 30 or 31) when the refrigerant leak detection system detects a leak. This will dilute the flammable A2L class refrigerant to a point that it no longer poses a risk of an explosion or fire. Follow the procedure “Verifying Proper Functioning of Refrigerant Leak Mitigation System” later in this section to confirm the refrigerant mitigation system is functioning as it should.

This air handler is equipped with a factory installed refrigerant leak detection system consisting of a refrigerant sensor with integral relays to perform the necessary leak mitigation if a refrigerant leak is detected by the sensor. Should a refrigerant leak occur in the indoor coil, the refrigerant leak detection system will energize the indoor blower and will open the 24VAC circuit to the outdoor unit compressor contactor. The circulation of air will disperse the leaked flammable refrigerant into the conditioned space where it will be diluted to point where it can no longer be ignited by an ignition source. The indoor blower will continue to operate until 5 minutes after the concentration of the refrigerant at the sensor drops below the sensor’s setpoint. Should the concentration of the refrigerant rise above the setpoint of the sensor, the mitigation cycle will repeat until the refrigerant concentration stays below the setpoint of the sensor. The sensor pigtail marked “ALARM” will normally be energized with 24VAC when no leak is detected and will be de-energized when a leak is detected for the purpose of notifying a building management system to issue a refrigerant leak alarm or to energize a leak warning light or audible alarm if a field supplied normally closed relay is installed (see Figure 30).

Should the sensor fail or if the sensor wiring is damaged or disconnected, the sensor will automatically enter the mitigation mode until the sensor is replaced or the wiring is reconnected or repaired.

## IMPORTANT

The outdoor unit control wiring must be connected to the refrigerant sensor “Y-CC” pigtail and the “COM” on the air handler low voltage terminal strip for the refrigerant detection system to de-energize the compressor during the leak mitigation mode of operation.

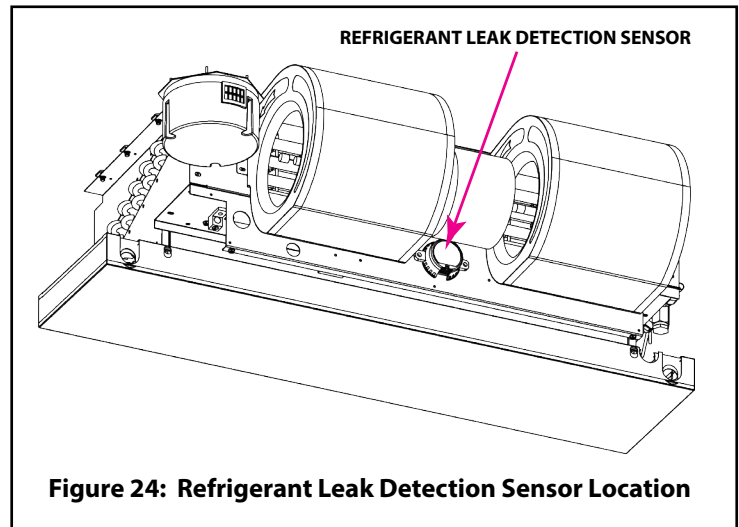

Figure 24: Refrigerant Leak Detection Sensor Location

### Verifying Proper Functioning of Refrigerant Leak Mitigation System

Follow the steps below to verify the proper functioning of the Refrigerant Leak Mitigation System.

1. Open the ceiling access panel below the air handler.
2. Locate the black refrigerant panel sensor located below the blower motor (See Figure 24).

#### Leak Detected During Cooling Cycle

3. Set the thermostat to “COOL” and the fan switch to “AUTO” and lower the temperature setpoint below the indoor temperature so the system enters the cooling mode.
4. Confirm the outdoor unit compressor is operating.
5. Within 30 seconds of the compressor starting, release a small amount of refrigerant on the refrigerant sensor to activate the leak mitigation mode.
6. Confirm the outdoor unit compressor and fan motor shut down and the indoor blower continues to operate.
7. Confirm the indoor blower is energized and 24V is not present at the air handler pigtail marked “ALARM”.
8. Confirm the outdoor unit compressor and fan motor are re-energized approximately 5 minutes after the flow of refrigerant near the sensor has ended and that the indoor blower continues to operate.

#### Leak Detected During the OFF Cycle

9. Set the thermostat to the “OFF” position and wait until the outdoor unit compressor and fan motor stop and indoor blower stops.
10. Release a small amount of refrigerant on the refrigerant sensor to activate the leak mitigation mode.
11. Confirm the indoor blower is energized and 24V is not present at the air handler pigtail marked “ALARM”.
12. Confirm the indoor blower shuts down after approximately 5 minutes after the flow of refrigerant on the refrigerant sensor has ended.
13. If the Refrigerant Leak Mitigation System does not operate as stated above, check for loose wiring connections or replace the refrigerant sensor.
14. Close the ceiling access panel and secure it with the thumb screws.
15. Set the thermostat to the desired operating mode and temperature.

If the leak detection system does not function properly when subjected to the above procedure, check for miswiring of the system. If the wiring connections are found to be correct per the air handler wiring diagram, replace the sensor with an approved replacement from the manufacturer.

### Leak Detection Sensor Replacement

When the refrigerant leak detection system sensor fails or reaches the end of its life, the leak detection system will enter and remain in the leak mitigation mode even though there is no refrigerant leak present. If the leak detection system continues to operate in the mitigation mode even when a refrigerant leak isn't indicated by a portable refrigerant leak detector, replace the sensor with an approved replacement from the air handler manufacturer. Disconnect the wiring harness connector from the failed sensor and remove the sensor mounting screws. Discard the failed sensor. Mount the replacement sensor in the same location as the failed sensor that was removed and connect the sensor wiring harness connector to the sensor.



## IMPORTANT

Mortex may source sensors from various manufacturers that have a different wiring harness connection. A wiring adapter may be necessary to allow the replacement sensor to connect the sensor wiring harness. The wiring adapter will be provided with the replacement sensor. Alternate mounting holes are provided to accommodate the various approved sensors. Only use a replacement sensor approved by and provided by Mortex to assure proper operating and compatibility.

Only the following replacement refrigerant sensors may be used for Mortex products:

**R-32 Refrigerant: R68ALL001**

**R-454B Refrigerant: R68ALL002**

**R-32/R454B Refrigerant (Dual Refrigerant Sensor): R68ALL003**



## IMPORTANT

The sensor wiring harness plug must be pointing down or horizontal. If the plug is pointing up, water could collect in the plug and result in operational issues.

### Minimum Circulating Airflow for Refrigerant Leak Mitigation

There is a minimum circulating airflow required when the refrigerant leak detection system is operating in the leak mitigation mode. This minimum depends on the total system refrigerant charge and can be found listed in Tables 30 and 31. The refrigerant mitigation system energizes the continuous fan speed on the air handler. The continuous fan CFM (l/s) may need to be increased to achieve the minimum leak mitigation circulating airflow level by changing to a different indoor blower motor speed tap or ECM motor setting that delivers the minimum mitigation airflow level. Refer to the blower performance tables and wiring diagrams in this manual to determine if this adjustment is necessary and if it is determined to be necessary to increase the continuous fan airflow level, follow the instructions in **SECTION 11: MOTOR SPEED SELECTION AND AIR HANDLER STARTUP** in this manual to make the necessary adjustment.

### Refrigerant Leak Alarm Output

The coil's refrigerant leak sensor has an alarm output signal that can be used as an input to a building management system or smart thermostat to alert the homeowner or user that the refrigerant detection system has detected a refrigerant leak and is in the leak mitigation mode. There is an ORANGE low voltage pigtail wire in the sensor harness labeled "ALARM". When the sensor is powered and no refrigerant leak is detected, the ORANGE "ALARM" pigtail wire is energized with 24 VAC indicating normal operation. When the refrigerant leak detection system detects a refrigerant leak and enters the leak mitigation mode (indoor blower energized and outdoor unit disabled), the ORANGE "ALARM" pigtail wire will be de-energized (0 VAC). The ORANGE "ALARM" pigtail wire is capped with a wire nut from the factory. Remove this wire nut and connect it to the building management system or smart thermostat as required if a refrigerant leak alert is desired. The building management system or smart thermostat shall be programmed to accept the reverse logic alarm signal (24 VAC – Normal; 0 VAC – Refrigerant Leak).

If a 24 VAC output when a refrigerant leak is detected is required. If a 24 VAC output when a refrigerant leak is detected is required to activate a warning light or audible alarm, the ORANGE "ALARM" pigtail wire shall be connected to the coil of a field supplied relay with normally closed contacts and a 24 VAC coil. An 18 AWG minimum wire from the furnace 24 VAC common circuit shall be connected to the other side of the relay coil. An 18 AWG minimum wire from the furnace 24 VAC "R" transformer circuit shall be connected to the terminal for one side of the normally closed relay contacts and an 18 AWG minimum wire to the warning light or audible alarm shall be connected to the other side of the normally closed relay contacts. All field supplied wiring shall be protected from damage. When no refrigerant leak is detected, the relay will be energized and the relay contacts will be open, disconnecting the 24 VAC signal to the warning light or audible alarm. When a refrigerant leak is detected, the relay will be de-energized and the contacts will close sending a 24 VAC signal to the warning light or audible alarm. See Figure 30 for suggested field wiring connections.

**WARNING**

To prevent accidental electrical shock, turn the electrical power "OFF" at the main electrical panel (circuit breaker box) and at the local service disconnect before removing the ceiling access panel to perform installation, maintenance and service on this air handler. Homeowners/users should never attempt to perform any maintenance which requires opening the ceiling access panel. Refer to Figures 9 and 10 for images of the ceiling access panel.

General wire and breaker sizes are shown in Tables 16–18. If sheathed cable is used, refer to NEC National Electrical Code (NFPA 70) or the Canadian Electrical Code, Part I (CSA C22.1) and local codes for additional requirements concerning supply circuit wiring. Electrical data can be found in Tables 16–18.

**IMPORTANT**

All field wiring must be rated for 60°C or higher. Refer to the wiring diagram on the air handler or the tables in these instructions for more information. Refer to the NEC National Electrical Code (NFPA 70) or the Canadian Electrical Code, Part I (CSA C22.1) and local codes for wiring material requirements.

**NOTE:** A means of disconnecting all poles of the line voltage power to the air handler must be provided in the field wiring within sight of the air handler unless the air handler is equipped with integral circuit breaker(s) with their ON/OFF lever(s) located on the outside of the air handler which can be used to disconnect line voltage electrical power to the air handler.

**Line Voltage Wiring Connections**

The unit internal wiring is complete except for the power supply and the thermostat wires. See wiring diagram and/or Tables 16 - 18 for wire size, fuse/circuit breaker size, and ground wire sizes. The use of cable connectors on incoming power supply wires to relieve any strain on wiring is recommended. Follow the steps below to connect the power supply wires.

1. Remove the thumb screws that secure ceiling access panel and slowly swing the panel down to access the air handler.
2. Remove the control box cover.
3. Install the cable connector in the 7/8 inch diameter hole on the bottom right side of the control box.
4. Strip 1/2 inch of the insulation off the end of each wire.
5. Insert the wires through the cable connector located in the 7/8 inch diameter hole in the air handler control box.
6. Connect the power supply wires to the power supply terminal block or pigtails located on the right side of the control box as follows.
7. Insert the BLACK line voltage wire into the L1 screw terminal on the power supply terminal block and tighten the set screw to clamp down on the wire or connect it to the BLACK line voltage pigtail with a wire nut or suitable electrical connector rated for the wire size. Insert the WHITE neutral (115 VAC) wire or RED line.

**NOTE:** Casing or cabinet must be permanently grounded in accordance with the National Electrical Code or other applicable codes.

	FAN COIL MODELS																	
	HE*1/HE*3-**-*-AC						HE*1/HE*3**-*-BC						HE*1/HE*3**-*-BC					
3 Kw Heater Amps - 208 / 240 VAC	10.83 / 12.50						10.83 / 12.50						10.83 / 12.50					
5 Kw Heater Amps - 208 / 240 VAC	18.06 / 20.83						18.06 / 20.83						18.06 / 20.83					
6 Kw Heater Amps - 20 / 240 VAC	21.67 / 25.00						21.67 / 25.00						21.67 / 25.00					
8 Kw Heater Amps - 208 / 240 VAC	28.89 / 33.33						28.89 / 33.33						28.89 / 33.33					
10 Kw Heater Amps - 208 / 240 VAC	36.11 / 41.67						36.11 / 41.67						36.11 / 41.67					
Indoor Blower Motor Code	*J						*K						*L					
Indoor Motor HP and Type	1/3 HP Constant Torque						1/3 HP Constant Torque						1/2 HP Constant Torque					
Indoor Blower Amps - 208 / 240 VAC	0.87 / 0.75						0.78 / 0.68						1.63 / 1.41					
Heater - kW	0	3	5	6	8	10	0	3	5	6	8	10	0	3	5	6	8	10
Minimum Circuit Ampacity - 240 VAC	0.94	16.56	26.98	32.19	42.60	53.02	0.85	16.48	26.89	32.10	42.52	52.93	1.76	17.39	27.80	33.01	43.43	53.85
Maximum Overcurrent Protection - 240 VAC	15	20	30	35	45	60	15	20	30	35	45	60	15	20	30	35	45	60

**Table 16: Wiring Requirements – 208/240 VAC Electric Heat, HE\*1/HE\*3-\*\*-\*-AC and HE\*1/HE\*3\*\*-\*-BC**

+ Refer to the National Electrical Code Table 250-95 for Non-Sheathed Conductor Ground Wire.

\* Ground conductor must be the same size and temperature rating as the other conductors listed in Table 16.

\*\* Circuit breakers must be HACR type.

	FAN COIL MODELS											
	HE*1/HE*3**.*-CC						HE*1/HE*3**.*-DC					
3 Kw Heater Amps - 208 / 240 VAC	10.83 / 12.50						10.83 / 12.50					
5 Kw Heater Amps - 208 / 240 VAC	18.06 / 20.83						18.06 / 20.83					
6 Kw Heater Amps - 20 / 240 VAC	21.67 / 25.00						21.67 / 25.00					
8 Kw Heater Amps - 208 / 240 VAC	28.89 / 33.33						28.89 / 33.33					
10 Kw Heater Amps - 208 / 240 VAC	36.11 / 41.67						36.11 / 41.67					
Indoor Blower Motor Code	*M						*M					
Indoor Motor HP and Type	1/2 HP Constant Torque						1/2 HP Constant Torque					
Indoor Blower Amps - 208 / 240 VAC	1.30 / 1.13						2.00 / 1.73					
Heater - kW	0	3	5	6	8	10	0	3	5	6	8	10
Minimum Circuit Ampacity - 240 VAC	1.41	17.04	27.45	32.66	43.08	53.50	2.16	17.79	28.20	33.41	43.83	54.25
Maximum Overcurrent Protection - 240 VAC	15	20	30	35	45	60	15	20	30	35	45	60

**Table 17: Wiring Requirements – 208/240 VAC Electric Heat, HE\*1/HE\*3\*\*.\*-CC, HE\*1/HE\*3\*\*.\*-DC**

+ Refer to the National Electrical Code Table 250-95 for Non-Sheathed Conductor Ground Wire.

\* Ground conductor must be the same size and temperature rating as the other conductors listed in Table 17.

\*\* Circuit breakers must be HACR type.

	HYDRONIC FAN COIL MODELS				
	HE*2/HE*4- **.*- AA	HE*2/HE*4- **.*- BA	HE*2/HE*4- **.*- BA	HE*2/HE*4- **.*- CA	HE*2/HE*4- **.*- DA
Indoor Blower Motor Code	*N	*O	*R	*R	*R
Indoor Motor HP and Type	1/ 3 HP C.T.	1/ 3 HP C.T.	1/ 2 HP C.T.	1/ 2 HP C.T.	1/ 2 HP C.T.
Indoor Blower Amps - 115VAC	1.63	1.67	3.64	3.25	3.02
Water Pump Amps	0.52	0.52	0.52	0.52	0.52
Minimum Circuit Ampacity - 115 VAC	2.69	2.74	5.20	4.71	4.43
Maximum Overcurrent Protection - 115 VAC	15	15	15	15	15

**Table 18: Wiring Requirements – 115 VAC Hot Water Heat HE\*2/HE\*4\*\*.\*-AA, HE\*2/HE\*4\*\*.\*-BA, HE\*2/HE\*4\*\*.\*-CA, HE\*2/HE\*4\*\*.\*-DA**

+ Refer to the National Electrical Code Table 250-95 for Non-Sheathed Conductor Ground Wire.

\* Ground conductor must be the same size and temperature rating as the other conductors listed in Table 18.

\*\* Circuit breakers must be HACR type.

		ELECTRIC HEATER SIZES				
		3 kW	5 kW	6 kW	8 kW	10 kW
240 VAC, 60 HZ, 1 PH	BTU	10,236	17,061	20,473	27,297	34,121
	Kw	3	5	6	8	10
230 VAC, 60 HZ, 1 PH	BTU	9,401	15,669	18,802	25,070	31,337
	Kw	2.76	4.59	5.51	7.35	9.18
220 VAC, 60 HZ, 1 PH	BTU	8,601	14,336	17,203	22,937	28,671
	Kw	2.52	4.20	5.04	6.72	8.40
HEATING ELEMENT CAPACITY	BTU	10,236	17,061	20,473	27,297	34,121
	Kw	3	5	6	8	10

**Table 19: Electric Heater Heating Capacity Data**

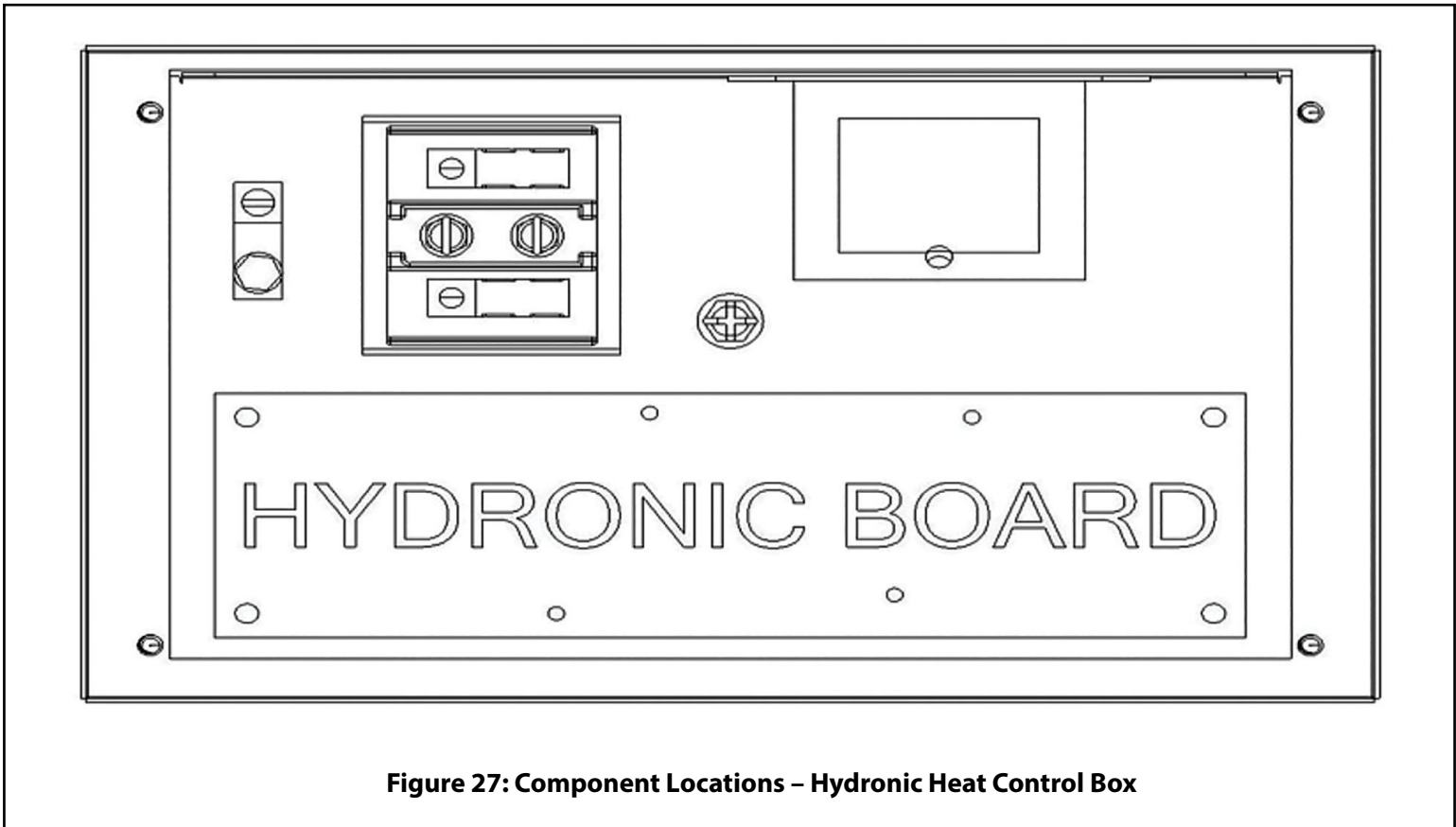
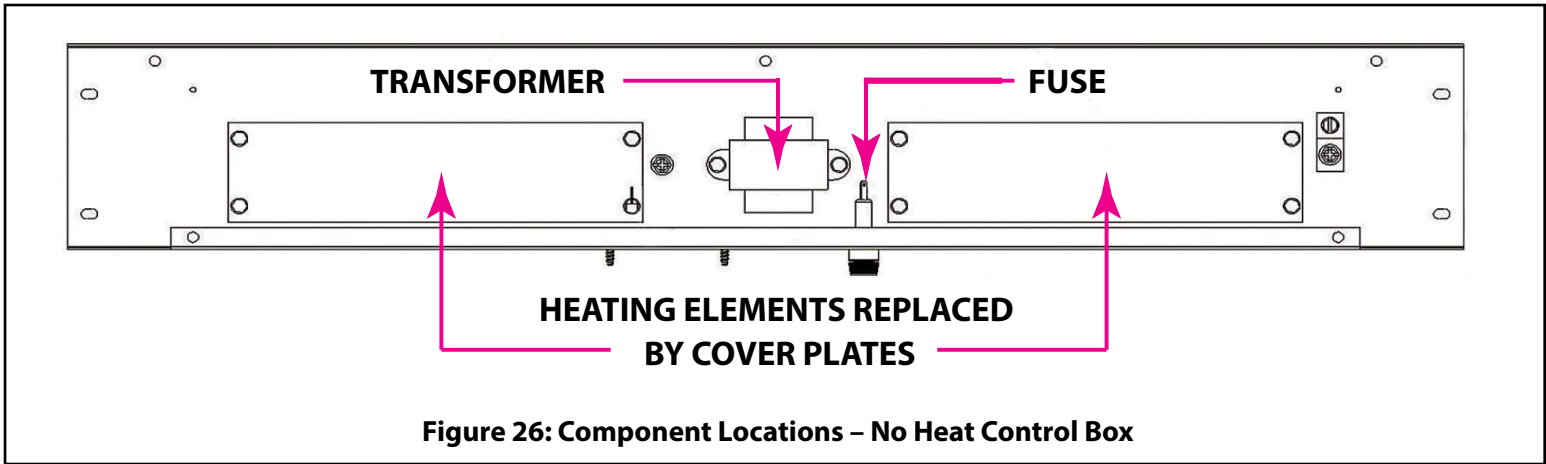
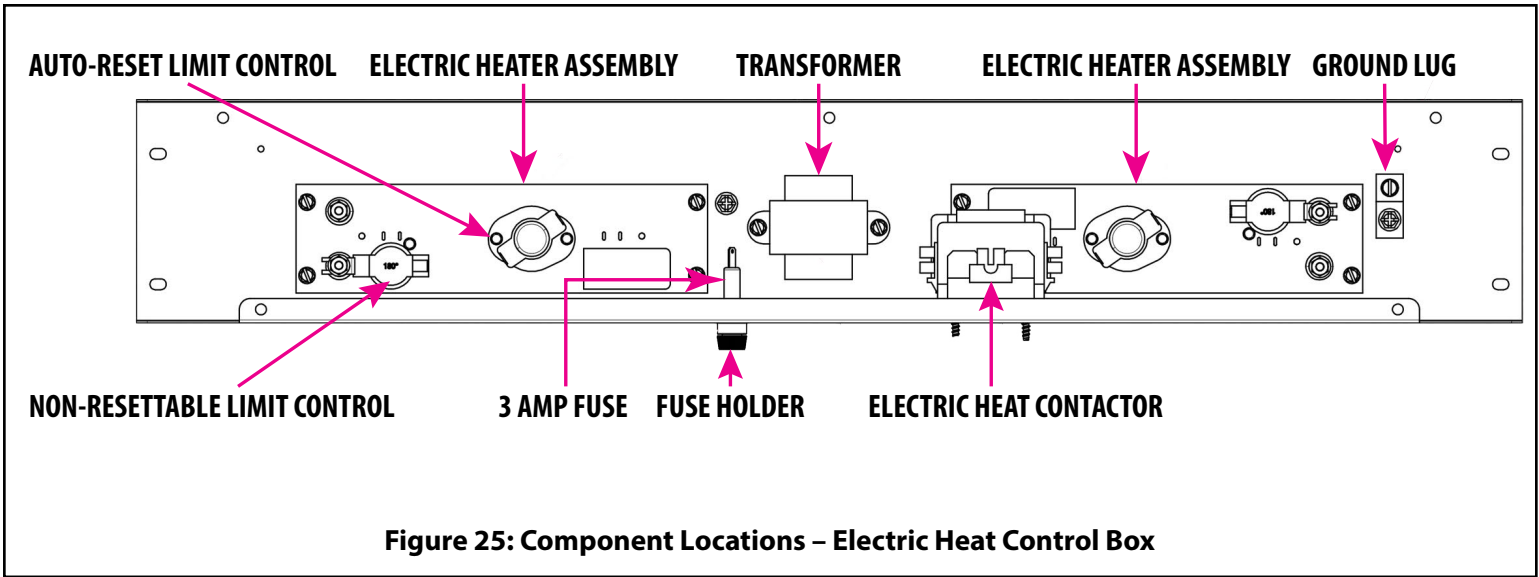

## SECTION 10: Thermostat Wiring and Connections

### Thermostat Wiring

Thermostat wires must be no smaller than 22 gauge. Thermostat wires connect through side of furnace and should be no smaller than 22 gauge. Refer to Table 20 for recommended wire gauge, lengths and maximum current for each wire gauge.

Max. Thermostat Wire Length	Thermostat Wire Gauge	Thermostat Wire Maximum Current
0 - 100 Feet	22	3.0 Amps
0 - 125 Feet	20	3.0 amps
0 - 250 Feet	18	3.0 amps

**Table 20: Low Voltage Wire Gauge and Max Lengths**

Thermostat wires can enter through the side of the unit. When bringing wiring through the side of the air handler, cable connectors must be installed to hold wiring in place and to relieve any strain on the wiring.

The use of a five-conductor cable from the thermostat to the air handler is recommended for typical heating or heating/cooling installations with a two or three-conductor cable from the air handler to the outdoor unit. The thermostat wire colors and the typical heating/cooling connections are listed in Table 22.

A seven-conductor cable from the thermostat to the air handler is recommended for a typical heat pump installation with a five-conductor cable from the air handler to the outdoor unit. Typical heat pump thermostat wire colors and connections are shown in Table 23.

### Thermostat Installation

The thermostat heat anticipator must be set at 0.4 amps if the thermostat has a manual heat anticipator adjustment. This setting should be checked at the time of installation. The thermostat may be a "self-setting" type in which no heat anticipator setting will be found on the thermostat, eliminating the need for field adjustment.

The thermostat should be located on an inside wall in an open area or hallway to more closely sense average room air, preferably where there is air movement back to air handler. The thermostat should not be located within 3 feet of from any windows or supply air registers and should be 52 to 66 inches above the floor.

Maintenance, operating, and/or programming instructions are in the envelope shipped with the thermostat. The envelope should be given to the homeowner or user after the thermostat installation is completed.

## CAUTION

Do not locate thermostat within three feet of any of the following items:

1. Supply air registers
2. Lights or heat lamps
3. Aquariums
4. Televisions, stereo, amplifiers, surround sound systems
5. Stoves or any cooking appliance
6. Refrigerator
7. Washer and/or dryer
8. Hot water tank
9. Sink or near any hot water
10. Within 15 feet of any electric space heater
11. Within two feet of any sunlight

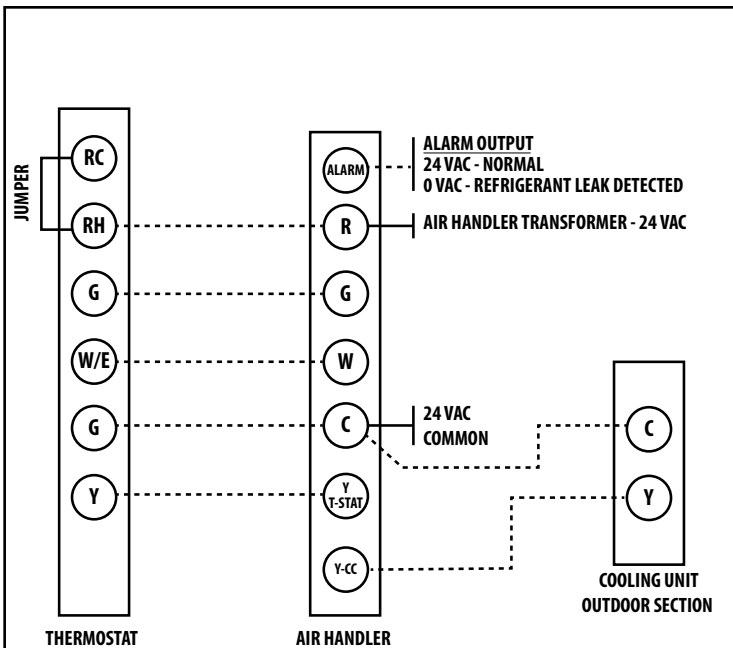

**Figure 28: Typical Low Voltage Connections - Straight Cooling with Electric or Hydronic Heat**

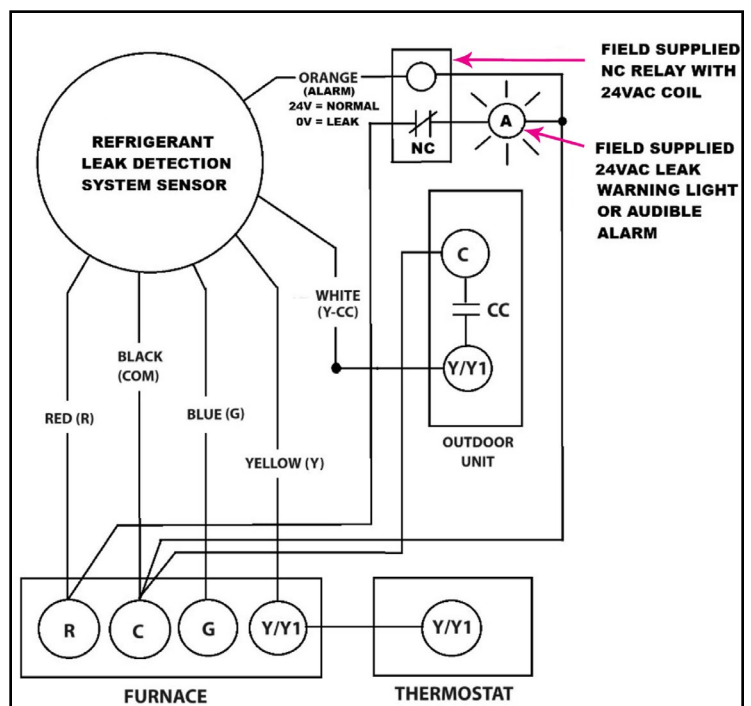

**Figure 30: Refrigerant Leak Detection System Wiring Connections**

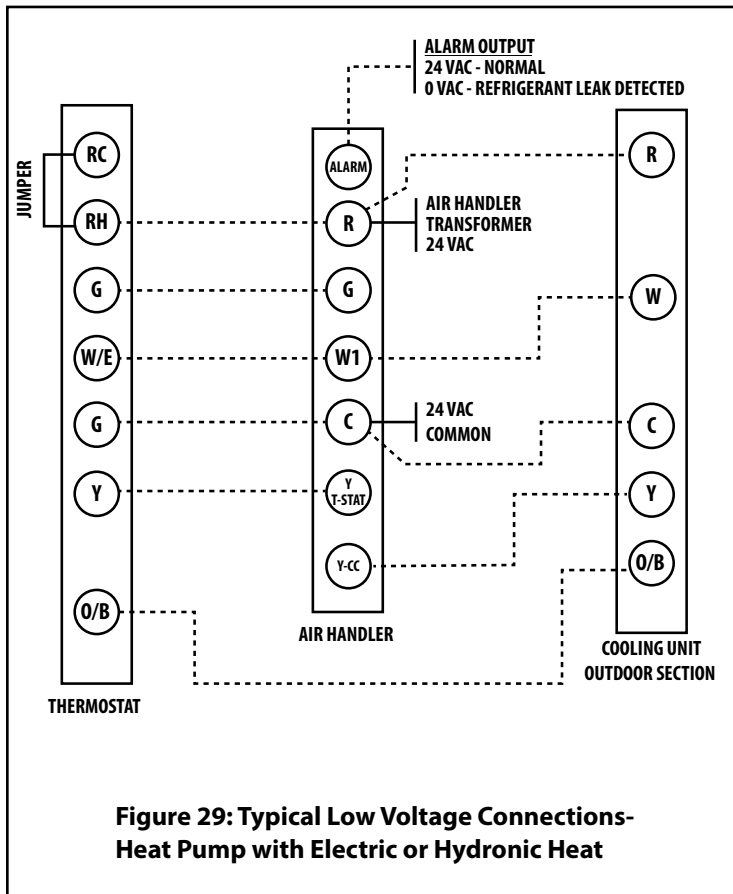

**Figure 29: Typical Low Voltage Connections - Heat Pump with Electric or Hydronic Heat**

WIRE COLOR	DESCRIPTION	LETTER CODE	THERMOSTAT CONNECTION
RED	24 VAC	RED / R	R
WHITE	Heat	WHT / W	W or W 1
GREEN	Indoor Fan	GRN / G	G
BLACK	24 VAC Common	BLK / C	C
WHITE	Y-CC (Compressor Contactor Output)	WHITE / Y-CC	N/A – Connects to Outdoor Unit CC
ORANGE	Refrigerant Leak Alarm - 24VAC = NO LEAK 0 VAC = LEAK	ORN / BK	See Refrigerant Leak Alarm Output Section on Page 28

**Table 21: Air Handler Low Voltage Pigtail Wire Colors and Connections**

WIRE COLOR	DESCRIPTION	LETTER CODE	THERMOSTAT CONNECTION
RED	24 VAC	RED / R	R
WHITE	Heat (1st Stage Heat)	WHT / W	W or W 1
GREEN	Indoor Fan	GRN / G	G
YELLOW	Cooling	YEL / C	Y or Y1
BROWN	24 VAC Common	BRN / C	C

**Table 22: Typical Heat/Cooling Outdoor Unit Thermostat Wire Color Codes and Connections**

WIRE COLOR	DESCRIPTION	LETTER CODE	THERMOSTAT CONNECTION
RED	24 VAC	RED / R	R
WHITE	Heat (1st Stage Heat)	WHT / W	W or W 1
GREEN	Indoor Fan	GRN / G	G
YELLOW	Cooling	YEL / C	Y or Y1
BROWN	24 VAC Common	BRN / C	C
ORANGE	Heat Pump Reversing Valve Solenoid (Most Brands)	ORN / O	O
BLUE	Heat Pump Reversing Valve Solenoid (Some Brands)	BLU / B	B

**Table 23: Typical Heat Pump Outdoor Unit Thermostat Wire Color Codes and Connections**

**IMPORTANT NOTES FOR HYDRONIC AIR HANDLERS**

- 1) The YELLOW wire from the thermostat "Y" terminal must connect to the YELLOW air handler thermostat pigtail or the "Y" terminal on the electronic hydronic control board and the "Y" signal wire (typically YELLOW) from the outdoor unit compressor contactor must connect to the "CC" terminal on the control board. The thermostat "Y" signal is passed from the "CLin" terminal to the "CLOut" terminal with a factory installed jumper wire. The CLOut terminal is connected to the "CC" terminal internally in the control board. The jumper between the CLin and CLOut terminals allows the "Y" signal to reach the CC terminal on applications without a compressor lockout switch. For applications where a compressor lock-out switch has been installed, this jumper is replaced with the two wires from the lock-out switch.
- 2) If the YELLOW wire from the thermostat "Y" terminal on a hydronic air handler is not connected to the YELLOW air handler thermostat pigtail (Y), the indoor blower motor will not operate in the cooling or heat pump heating mode which will result in no cooling and frosting up of the indoor coil in the cooling mode or no heating and excessive compressor head pressures in the heat pump heating mode.

## Typical Heating/ Cooling Wiring Connections

1. Open the ceiling access panel.
2. Remove the control box cover.
3. Install a grommet or a strain relief in the 9/16 inch diameter hole on the top and the left side of the air handler to protect the thermostat wire cable.
4. Strip 1/2 inch of the insulation off the end of each wire.
5. Insert the wire cable from the thermostat thru the 9/16 inch hole into the control box and place the thermostat wire cable next to the low voltage pigtailed. Secure the thermostat wire cable with a strain relief to prevent wire connections from being pulled apart.
6. Connect the RED (24 VAC) thermostat wire to the RED air handler pigtail with a wire nut.
7. Connect the WHITE (1st stage heating) thermostat wire to the WHITE air handler low voltage pigtail wire with a wire nut.
8. Connect the GREEN (indoor fan) thermostat wire to the GREEN air handler low voltage pigtail wire with a wire nut.
9. Connect the YELLOW (cooling) wire from the thermostat "Y" terminal to the YELLOW air handler pigtail wire with a wire nut.
10. Connect the WHITE air handler pigtail labeled "Y-CC" to the wire from the outdoor unit compressor contactor coil with a wire nut.
11. Connect the BROWN (24 VAC common) wire from the thermostat to the air handler BROWN low voltage pigtail wire and to the BROWN (24 VAC common) wire from the "C" terminal on the outdoor unit. Fasten the 3 wires together securely with a wire nut.
12. If a refrigerant leak alert is desired and a building management system or smart thermostat capable of providing that alert is being used, removed the wire nut from the end of the ORANGE pigtail wire labeled "ALARM" and connect it to the appropriate building management system or smart thermostat connections. A field supplied normally closed relay and warning light or audible alarm may also be connected to the ORANGE sensor wire labeled "ALARM" as shown in Figure 30. See "Refrigerant Leak Alarm Output" on page 28 for additional information.

## Typical Heat Pump Wiring Connections

1. Open the ceiling access panel.
2. Remove the control box cover.
3. Install a grommet or a strain relief in the 9/16 inch diameter hole on the top and the left side of the air handler to protect the thermostat wire cable.
4. Strip 1/2 inch of the insulation from the end of each wire.
5. Insert the wire cable from the thermostat thru the 9/16 inch hole into the control box and place the thermostat wire cable next to the low voltage pigtailed. Secure the thermostat wire cable with a strain relief to prevent wire connections from being pulled apart.
6. Connect the RED (24 VAC) wire from the thermostat to the RED air handler low voltage pigtail wire and the RED wire from the "R" terminal on the outdoor unit. Fasten the three wires together securely with a wire nut.
7. Connect the WHITE (1st stage heating) wire from the thermostat to the WHITE air handler low voltage pigtail wire and the WHITE wire from the "E" terminal on the outdoor unit. Fasten the three wires together securely with a wire nut.
8. Connect the GREEN (indoor fan) wire from the thermostat to the GREEN air handler low voltage pigtail wire with a wire nut.

9. Connect the YELLOW (cooling) wire from the thermostat "Y" terminal to the YELLOW air handler pigtail wire with a wire nut.
10. Connect the WHITE air handler pigtail labeled "Y-CC" to the wire from the outdoor unit compressor contactor coil with a wire nut.
11. Connect the BROWN (24 VAC common) wire from the thermostat to the air handler BROWN low voltage pigtail wire and to the BROWN (24 VAC common) wire from the "C" terminal on the outdoor unit. Fasten the 3 wires together securely with a wire nut.
12. Connect the BROWN (24 VAC common) wire from the thermostat to the BROWN air handler low voltage pigtail wire and to the BROWN (24 VAC common) wire from the "C" terminal on the outdoor unit. Fasten the 3 wires together securely with a wire nut.
13. Connect the ORANGE (reversing valve solenoid) wire from the thermostat "O" terminal to the ORANGE wire from the "O" terminal on the outdoor unit. Fasten the two wires together securely with a wire nut.

**NOTE:** If the outdoor unit has a "B" terminal instead of an "O" terminal, connect the BLUE (reversing valve solenoid) wire from the thermostat "B" terminal to the BLUE wire from the "B" terminal on the outdoor unit.

14. If a refrigerant leak alert is desired and a building management system or smart thermostat capable of providing that alert is being used, removed the wire nut from the end of the ORANGE pigtail wire labeled "ALARM" and connect it to the appropriate building management system or smart thermostat connections. A field supplied normally closed relay and warning light or audible alarm may also be connected to the ORANGE sensor wire labeled "ALARM" as shown in Figure 30. See "Refrigerant Leak Alarm Output" on page 28 for additional information.

## IMPORTANT NOTES FOR HYDRONIC AIR HANDLERS:

- 1) The YELLOW wire from the thermostat "Y" terminal must connect to the YELLOW air handler thermostat pigtail or the "Y" terminal on the electronic hydronic control board and the "Y" signal wire (typically YELLOW) from the outdoor unit compressor contactor must connect to the "CC" terminal on the control board. The thermostat "Y" signal is passed from the "CLin" terminal to the "CLout" terminal with a factory installed jumper wire or the Compressor Lockout Switch which may be factory or field installed on the hot water coil. The CLout terminal is connected to the "CC" terminal internally in the control board. The jumper between the CLin and CLout terminals allows the "Y" signal to reach the CC terminal on applications without a compressor lockout switch. For applications where a compressor lock-out switch has been installed, this jumper is replaced with the two wires from the lock-out switch.
- 2) If the YELLOW wire from the thermostat "Y" terminal on a hydronic air handler is not connected to the YELLOW air handler thermostat pigtail (Y), the indoor blower motor will not operate in the cooling or heat pump heating mode which will result in no cooling and frosting up of the indoor coil in the cooling mode or no heating and excessive compressor head pressures in the heat pump heating mode.

**SECTION 11: BLOWER MOTOR SPEED SELECTION AND MOTOR REPLACEMENT**

**⚠ WARNING**

To avoid personal injury or property damage, make certain that the motor leads cannot contact non-insulated metal components of the air handler.

**NOTICE**

The factory motor speed tap settings are appropriate for most applications. Refer to the blower performance tables in Section 13 before changing the motor speeds from the factory settings.

**⚠ WARNING**

This air handler is equipped with a refrigerant leak mitigation system that energizes the blower motor to deliver at least the required minimum airflow when the refrigerant leak detection system detects a leak (See Tables 30 and 31). This will dilute the flammable A2L class refrigerant to a point that it no longer poses a risk of an explosion or fire. Follow the procedure in Section 12: Final System Startup and Check-Out to confirm the refrigerant mitigation system is functioning as it should.

**CONSTANT TORQUE MOTOR**

This air handler is equipped with a high efficiency constant torque motor that operates on 208/240 VAC for electric heat models and 115 VAC for hydronic heat models. The motor speed tap inputs are 24 VAC. The speed taps can be changed by removing the BLACK wire from the blower motor control module terminal 5 or the RED wire from the blower motor control module terminal 1 and connecting the wires to blower motor control module terminals 2, 3 or 4. Figure 32, Table 24, and Table 25 show the constant torque motor control module terminals and connection definitions.

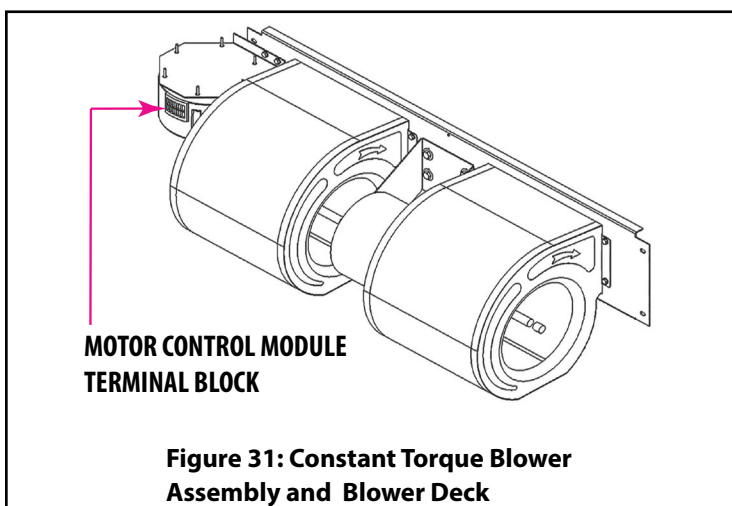

**Figure 31: Constant Torque Blower Assembly and Blower Deck**

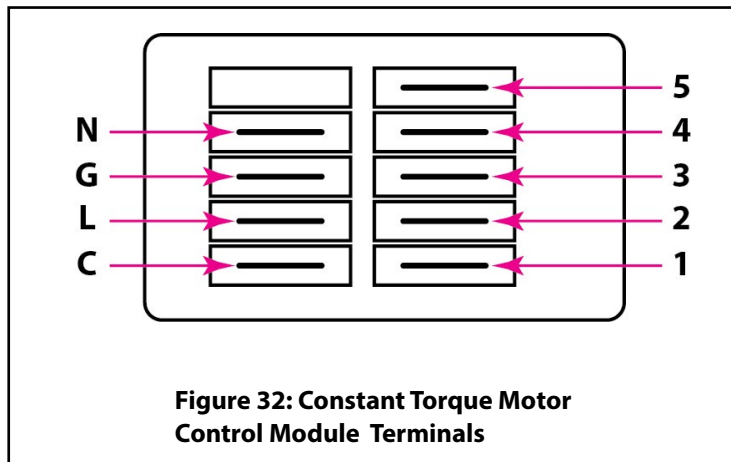

**Figure 32: Constant Torque Motor Control Module Terminals**

TERMINAL	CONNECTION
C	Speed Tap Common - 24 VAC Common
L	Supply Voltage – 208/240 VAC – Line 1
G	Ground Connection
N	Supply Voltage – 208/240 VAC – Line 2
1	Low Speed Tap - 24 VAC Input
2	Medium - Low Speed Tap - 24 VAC Input
3	Medium Speed Tap - 24 VAC Input
4	Medium - High Speed Tap - 24 VAC Input
5	High Speed Tap - 24 VAC Input

**Table 24: Constant Torque Motor Terminals – Electric Heat Models**

TERMINAL	CONNECTION
C	Speed Tap Common - 24 VAC Common
L	Supply Voltage - 115 VAC
G	Ground Connection
N	Supply Voltage - Neutral
1	Low Speed Tap - 24 VAC Input
2	Medium - Low Speed Tap - 24 VAC Input
3	Medium Speed Tap - 24 VAC Input
4	Medium - High Speed Tap - 24 VAC Input
5	High Speed Tap - 24 VAC Input

**Table 25: Constant Torque Motor Terminals – Hydronic Heat Models**

**Changing Motor Speeds – Constant Torque Motor**

1. Turn off all electrical supply circuits to the air handler at the main electrical panel (circuit breaker box) and turn the local air handler service disconnect to the OFF position.
2. Loosen the ceiling access panel thumbscrews and lower access panel. Disconnect the speed tap wire(s) connected to blower motor control module terminals 1 through 5 (See Figure 32) and reconnect to the desired terminal(s).

### Constant Torque Motor Speed Tap Wire Color Code:

**ORANGE** - Cooling Speed; **WHITE** - Heating Speed;

**YELLOW** - Continuous Fan Speed

**NOTE:** Motor speed tap terminal 1 is the lowest speed and 5 is the highest speed. The cooling speed should be higher than the heating speed.

1. Close the ceiling access panel and secure the panel with the thumb screws.
2. Turn on all electrical supply circuits to the air handler at the main electrical panel (circuit breaker box) and turn the local air handler service disconnect to the ON position.
3. Set the thermostat to the desired operating mode and temperature.

## SECTION 12: FINAL SYSTEM CHECKOUT AND STARTUP

1. Refer to appropriate wiring diagram and recheck all wiring connections. Ensure that all wiring connections are tight.
2. Check blower motor connectors to make sure they are not damaged or loose.
3. If the control box cover was removed; reinstall control box cover.
4. Swing the service access panel into place and secure with the thumb screws.
5. Switch the air handler circuit breakers in the main electrical panel to the ON position.
6. Switch the air handler service disconnect switch to the ON position.
7. Set the thermostat FAN Switch to the ON position to enable the continuous fan mode.
8. Check for air leaks at all duct connections and seal any leaks that are found.
9. Set the thermostat FAN switch to the AUTO position.
10. Set the thermostat HEAT/COOL switch to the COOL position and adjust the set point below the room temperature to enable the cooling mode.
11. Check for proper cooling operation per the outdoor unit installation and operating instructions.
12. **Electric Heat Models Only:** Switch the thermostat HEAT/COOL switch to the HEAT position and adjust the set point above the room temperature to enable the heating mode. Check for proper heating operation. Set the thermostat to the desired operating mode and adjust the temperature setting for comfort conditions.
13. **Hydronic Heat Models Only:** Switch the thermostat HEAT/COOL switch to the OFF position. The heating mode in models with hydronic heating system should not be switched on until system is filled and air is purged from hot water coil using the following procedure.

### Filling Hydronic Heating System With Water, Purging Air From System, and System Startup

1. The thermostat HEAT/COOL switch must be in the OFF position.
2. Fill and pressurize the water heater and water coil.
3. Check for water leaks and seal any leaks that are found.
4. Turn the water heater on and set water temperature at 130°F for now.
5. Vent air from the water tank by opening a hot water spigot or faucet.
6. Vent and flush the supply and return water lines by attaching a hose to the volume purge valve and running purge water to

a safe location. Run approximately 5 gallons of water at a high flow rate to purge.

7. Switch the air handler circuit breaker in the main electrical panel to the ON position if it is not already in the ON position.
8. Switch the air handler service disconnect switch to the ON position if it is not already in the ON position.
9. Set the thermostat HEAT/COOL switch to the HEAT position band adjust the set point above the room temperature to call for heat. The fan and water pump (provided a water pump is present) should start simultaneously. The water coil should be warm after a few minutes of operation.
10. The air handler is rated for water temperatures of 130° - n 180°F. Set water heater temperature at design temperature and take proper safeguards for water usage at supply points per local codes and safety considerations.

**NOTE:** If CPVC or PEX hot water tubing is used, do not set the water temperature above 150°F.

11. Set thermostat HEAT/COOL switch to the desired operating mode and adjust the temperature setting for comfort conditions.

### Verifying Proper Functioning of Refrigerant Leak Mitigation System

A test to confirm the proper functioning of the refrigerant leak mitigation system must be performed at the final system check-out. Follow the procedure below to perform that test.

1. Open the ceiling access panel under the air handler.
2. Locate the black refrigerant sensor located below the blower motor (see Figure 24).

### Leak Detected During Cooling Cycle

3. Set the thermostat to "COOL" and the fan switch to "AUTO" and lower the temperature setpoint below the indoor temperature so the system enters the cooling mode.
4. Confirm the outdoor unit compressor is operating.
5. Within 30 seconds of the compressor starting, release a small amount of refrigerant on the refrigerant sensor to activate the leak mitigation mode.
6. Confirm the outdoor unit compressor and fan motor shut down and the indoor blower continues to operate.
7. Confirm the indoor blower is energized and 24V is not present at the air handler pigtail marked "ALARM".
8. Confirm the outdoor unit compressor and fan motor are re-energized approximately 5 minutes after the flow of refrigerant near the sensor has ended and that the indoor blower continues to operate.

### Leak Detected During the OFF Cycle

9. Set the thermostat to the "OFF" position and wait until the outdoor unit compressor and fan motor stop and indoor blower stops.
10. Release a small amount of refrigerant on the refrigerant sensor to activate the leak mitigation mode.
11. Confirm the indoor blower is energized and 24V is not present at the air handler pigtail marked "ALARM".
12. Confirm the indoor blower shuts down after approximately 5 minutes after the flow of refrigerant on the refrigerant sensor has ended.
13. If the Refrigerant Leak Mitigation System does not operate as stated above, check for loose wiring connections or replace the refrigerant sensor.
14. Close the ceiling access panel and secure it with the thumb screws.

15. Set the thermostat to the desired operating mode and temperature.

If the leak detection system does not function properly when subjected to the above procedure, check for miswiring of the system. If the wiring connections are found to be correct per the air handler wiring diagram, replace the sensor with an approved replacement from the manufacturer using the following procedure.

#### **Leak Detection Sensor Replacement**

When the refrigerant leak detection sensor fails or reaches the end of its life, the leak detection sensor will enter and remain in the leak mitigation mode even though there is no refrigerant leak present. If the leak detection system continues to operate in the mitigation mode even when a refrigerant leak isn't indicated by a portable refrigerant leak detector, replace the sensor with an approved replacement from the air coil manufacturer. Disconnect the wiring harness connector from the failed sensor and remove the sensor mounting screws. Discard the failed sensor. Mount the replacement sensor in the same location as the failed sensor that was removed and connect the sensor wiring harness connector to the sensor. Verify the proper function of the refrigerant leak mitigation system using the **"Verifying Proper Functioning of Refrigerant Leak Mitigation System"** above.



## **IMPORTANT**

Mortex may source sensors from various manufacturers that have a different wiring harness connection. A wiring adapter may be necessary to allow the replacement sensor to connect the sensor wiring harness. The wiring adapter will be provided with the replacement sensor. Alternate mounting holes are provided to accommodate the various approved sensors. Only use a replacement sensor approved by and provided by Mortex to assure proper operating and compatibility. Only the following refrigerant sensors may be used for Mortex products:

**R-32 Refrigerant: R68ALL001**

**R-454B Refrigerant: R68ALL002**

**R-32/R-454B Refrigerant (Dual Refrigerant Sensor): R68ALL003**



## **IMPORTANT**

The sensor wiring harness plug must be pointing down or horizontal. If the plug is pointing up, water could collect in the plug and result in operational issues.

**SECTION 13: BLOWER PERFORMANCE TABLES**

Model No.	Nominal Cooling Tons	Blower Motor		Motor Code	Blower Wheel Size	Motor Speed Tap	CFM@	CFM@	CFM@	CFM@	CFM@
		HP	Volts				0.10" W.C.	0.20" W.C.	0.30" W.C.	0.40" W.C.	0.50" W.C.
HE*1-**-*-A Electric HE*3-**-*-A Electric	1.5 - 2.0	0.33	240	*J	(2) 7 x 8	1	541	482	416	357	315
						2	646	598	541	482	438
						3	735	694	659	597	549
						4	840	804	770	735	672
						5	888	851	819	785	739
HE*1-**-*-B Electric HE*3-**-*-B Electric	1.5 - 2.5	0.33	240	*K	(2) 7 x 9	1	570	480	398	327	257
						2	669	588	512	450	387
						3	761	691	618	557	499
						4	865	797	730	667	609
						5	915	851	782	724	657
HE*1-**-*-B Electric HE*3-**-*-B Electric	1.5 - 2.5	0.5	240	*L	(2) 7 x 8	1	906	837	762	701	627
						2	1019	955	887	822	768
						3	1101	1043	987	922	846
						4	1202	1151	1098	1041	981
						5	1312	1258	1209	1151	1105
HE*1-**-*-C Electric HE*3-**-*-C Electric	1.5 - 3.0	0.5	240	*M	(2) 7 x 9	1	928	836	750	689	617
						2	1024	948	866	798	739
						3	1131	1062	989	917	846
						4	1225	1160	1091	1026	957
						5	1327	1267	1211	1138	1075
HE*1-**-*-D Electric HE*3-**-*-D Electric	1.5 - 3.0	0.5	240	*M	(2) 7 x 9	1	987	922	849	769	696
						2	1073	1008	945	880	817
						3	1191	1127	1071	1006	949
						4	1285	1241	1186	1127	1047
						5	1400	1332	1290	1246	1191

**Table 26: HE\*1/HE\*3 Blower Performance – CFM – Without Air Filters**

Minimum CFM for Electric Heat: 3kW = 195 CFM; 5kW = 325 CFM; 6kW = 390 CFM; 8kW = 520 CFM; 10kW = 650 CFM

Model No.	Nominal Cooling	Blower Motor		Motor Code	Blower Wheel	Motor Speed	AMPS@ 0.10"W.C.	AMPS@ 0.20"W.C.	AMPS@ 0.30"W.C.	AMPS@ 0.40"W.C.	AMPS@ 0.50"W.C.
		HP	Volts								
HE*1-**-*-A Electric  HE*3-**-*-A Electric	1.5 - 2.0	0.33	240	*J	(2) 7 x 8	1	0.28	0.30	0.33	0.36	0.38
						2	0.36	0.39	0.43	0.45	0.48
						3	0.47	0.50	0.53	0.56	0.59
						4	0.62	0.64	0.67	0.70	0.74
						5	0.69	0.72	0.75	0.78	0.81
HE*1-**-*-B Electric  HE*3-**-*-B Electric	1.5 - 2.5	0.33	240	*K	(2) 7 x 9	1	0.27	0.30	0.33	0.35	0.37
						2	0.35	0.38	0.41	0.44	0.47
						3	0.44	0.47	0.50	0.53	0.56
						4	0.55	0.59	0.62	0.66	0.69
						5	0.62	0.65	0.68	0.72	0.75
HE*1-**-*-B Electric  HE*3-**-*-B Electric	1.5 - 2.5	0.5	240	*L	(2) 7 x 8	1	0.61	0.65	0.66	0.68	0.71
						2	0.74	0.78	0.81	0.83	0.86
						3	0.87	0.92	0.95	0.97	0.99
						4	1.08	1.11	1.13	1.16	1.20
						5	1.33	1.36	1.41	1.43	1.46
HE*1-**-*-C Electric  HE*3-**-*-C Electric	1.5 - 3.0	0.5	240	*M	(2) 7 x 9	1	0.51	0.54	0.57	0.61	0.64
						2	0.62	0.66	0.70	0.72	0.76
						3	0.75	0.78	0.82	0.85	0.88
						4	0.88	0.92	0.96	0.98	1.04
						5	1.08	1.12	1.13	1.16	1.21
HE*1-**-*-D Electric  HE*3-**-*-D Electric	1.5 - 3.0	0.5	240	*M	(2) 7 x 9	1	0.75	0.78	0.81	0.85	0.88
						2	0.90	0.94	0.95	1.00	1.03
						3	1.10	1.13	1.16	1.16	1.20
						4	1.35	1.38	1.42	1.46	1.50
						5	1.66	1.70	1.73	1.77	1.80

**Table 27: HE\*1/HE\*3 Blower Performance – Motor Amps – Without Air Filters**

Model No.	Nominal Cooling Tons	Blower Motor		Motor Code	Blower Wheel Size	Motor Speed	CFM@	CFM@	CFM@	CFM@	CFM@
		HP	Volts				0.10"W.C.	0.20"W.C.	0.30"W.C.	0.40"W.C.	0.50"W.C.
HE*2-**-*-A Hydronic	1.5 - 2.0	0.33	115	*N	(2) 7 X 8	1	533	485	439	397	350
						2	629	589	546	508	457
						3	728	694	658	625	579
						4	832	801	761	727	680
						5	886	857	818	786	740
HE*4-**-*-A Hydronic	1.5 - 2.0	0.33	115	*N	(2) 7 X 8	1	556	486	426	363	291
						2	646	593	541	476	423
						3	749	699	651	598	555
						4	844	798	749	704	657
						5	897	854	809	764	721
HE*2-**-*-B Hydronic	1.5 - 2.5	0.33	115	*O	(2) 7 X 9	1	883	834	787	737	700
						2	978	926	885	834	791
						3	1075	1033	991	946	905
						4	1192	1149	1105	1071	1029
						5	1302	1253	1213	1176	1138
HE*4-**-*-B Hydronic	1.5 - 2.5	0.50	115	*P	(2) 7 X 8	1	903	845	791	732	665
						2	1016	958	903	853	789
						3	1118	1065	1010	958	912
						4	1232	1179	1135	1089	1047
						5	1310	1261	1221	1180	1137
HE*2-**-*-C Hydronic	1.5 - 3.0	0.50	115	*R	(2) 7 X 9	1	901	837	781	716	658
						2	992	939	876	823	753
						3	1090	1043	987	934	878
						4	1200	1152	1107	1061	1012
						5	1297	1252	1205	1161	1111
HE*4**-*-D Hydronic	1.5 - 3.0	0.50	115	*R	(2) 7 X 9	1	901	837	781	716	658
						2	992	939	876	823	753
						3	1090	1043	987	934	878
						4	1200	1152	1107	1061	1012
						5	1297	1252	1205	1161	1111

**Table 28: HE\*2/HE\*4 Blower Performance – CFM – Without Air Filters**

Model No.	Nominal Tons	Motor HP	Volts 1 Ph. 50/60	Motor Code	Blower Wheel	Motor Tap	AMPS @ 0.10" W.C.	AMPS @ 0.20" W.C.	AMPS @ 0.30" W.C.	AMPS @ 0.40" W.C.	AMPS @ 0.50" W.C.	
HE*2-**-*-A Hydronic	1.5 - 2.0	0.33	115	*N	(2) 7 X 8	1	0.52	0.56	0.61	0.65	0.70	
						2	0.75	0.79	0.84	0.88	0.92	
						HE*4-**-*-A Hydronic	3	1.02	1.06	1.08	1.14	1.21
						4	1.30	1.36	1.42	1.46	1.50	
						5	1.53	1.56	1.63	1.66	1.71	
HE*2-**-*-B Hydronic	1.5 - 2.5	0.33	115	*O	(2) 7 X 9	1	0.54	0.58	0.63	0.68	0.74	
						2	0.71	0.76	0.81	0.88	0.94	
						HE*4-**-*-B Hydronic	3	1.01	1.04	1.08	1.14	1.22
						4	1.32	1.37	1.45	1.49	1.54	
						5	1.57	1.63	1.67	1.72	1.78	
HE*2-**-*-B Hydronic	1.5 - 2.5	0.50	115	*P	(2) 7 X 8	1	1.39	1.44	1.51	1.53	1.55	
						2	1.72	1.76	1.82	1.88	1.93	
						HE*4-**-*-B Hydronic	3	2.20	2.25	2.29	2.32	2.41
						4	2.77	2.90	2.94	3.04	3.02	
						5	3.54	3.53	3.64	3.68	3.65	
HE*2-**-*-C Hydronic	1.5 - 3.0	0.50	115	*R	(2) 7 X 9	1	1.20	1.25	1.31	1.36	1.41	
						2	1.59	1.62	1.68	1.71	1.76	
						HE*4-**-*-C Hydronic	3	1.93	1.99	2.06	2.08	2.15
						4	2.52	2.57	2.61	2.66	2.74	
						5	3.15	3.19	3.25	3.29	3.35	
HE*2-**-*-D Hydronic	1.5 - 3.0	0.50	115	*R	(2) 7 X 9	1	1.21	1.29	1.32	1.38	1.44	
						2	1.47	1.53	1.63	1.66	1.68	
						HE*4-**-*-D Hydronic	3	1.89	1.93	2.01	2.04	2.08
						4	2.40	2.45	2.52	2.54	2.60	
						5	2.86	2.96	3.02	3.04	3.10	

**Table 29: HE\*2/HE\*4 Blower Performance – Motor Amps – Without Air Filters**

SECTION 14: WIRING DIAGRAMS

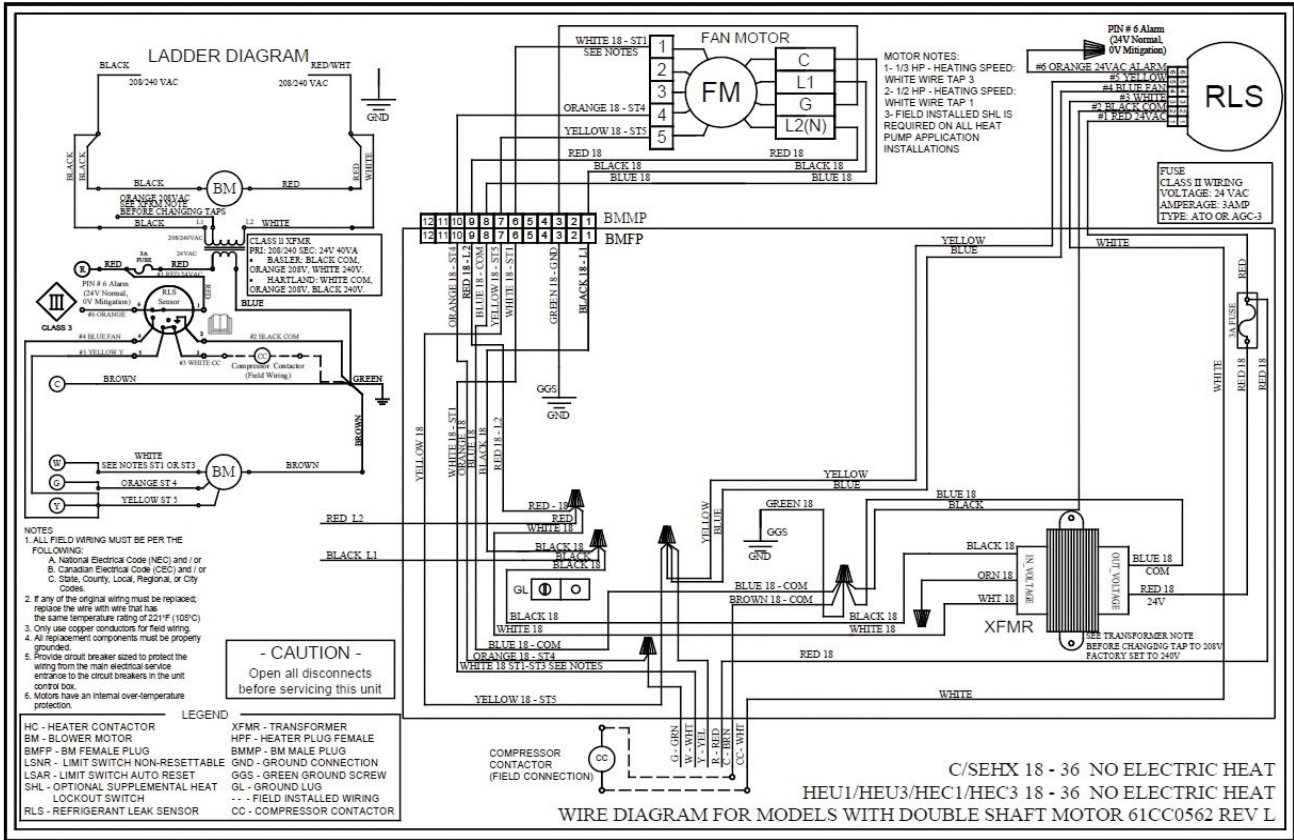

Figure 33: HE\*1/HE\*3 - No Electric Heat - Constant Torque Motor

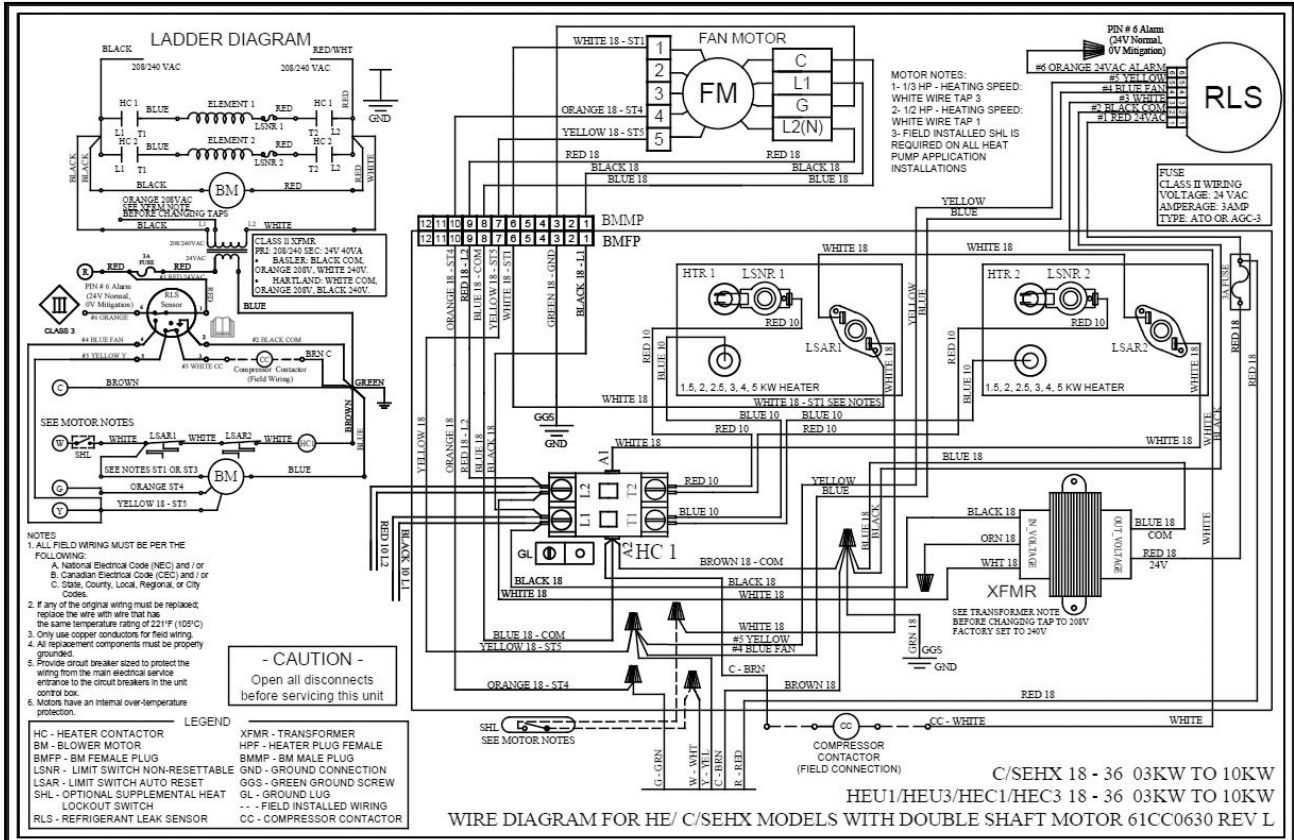

Figure 34: HE\*1/HE\*3 - 03kW to 10kW Electric Heat - Constant Torque Motor

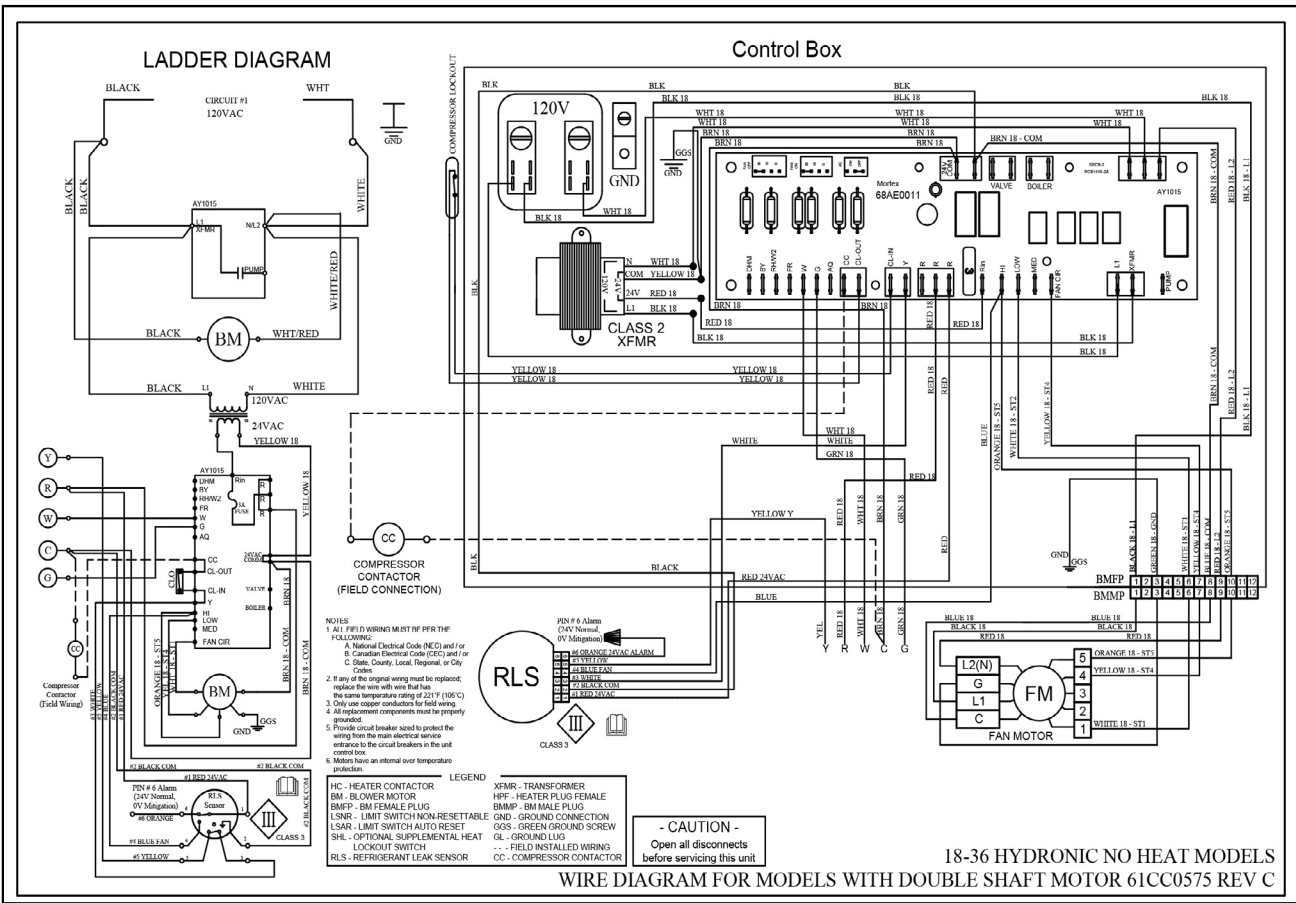

Figure 35: HE\*2/HE\*4 – No Hydronic Heat – Constant Torque Motor

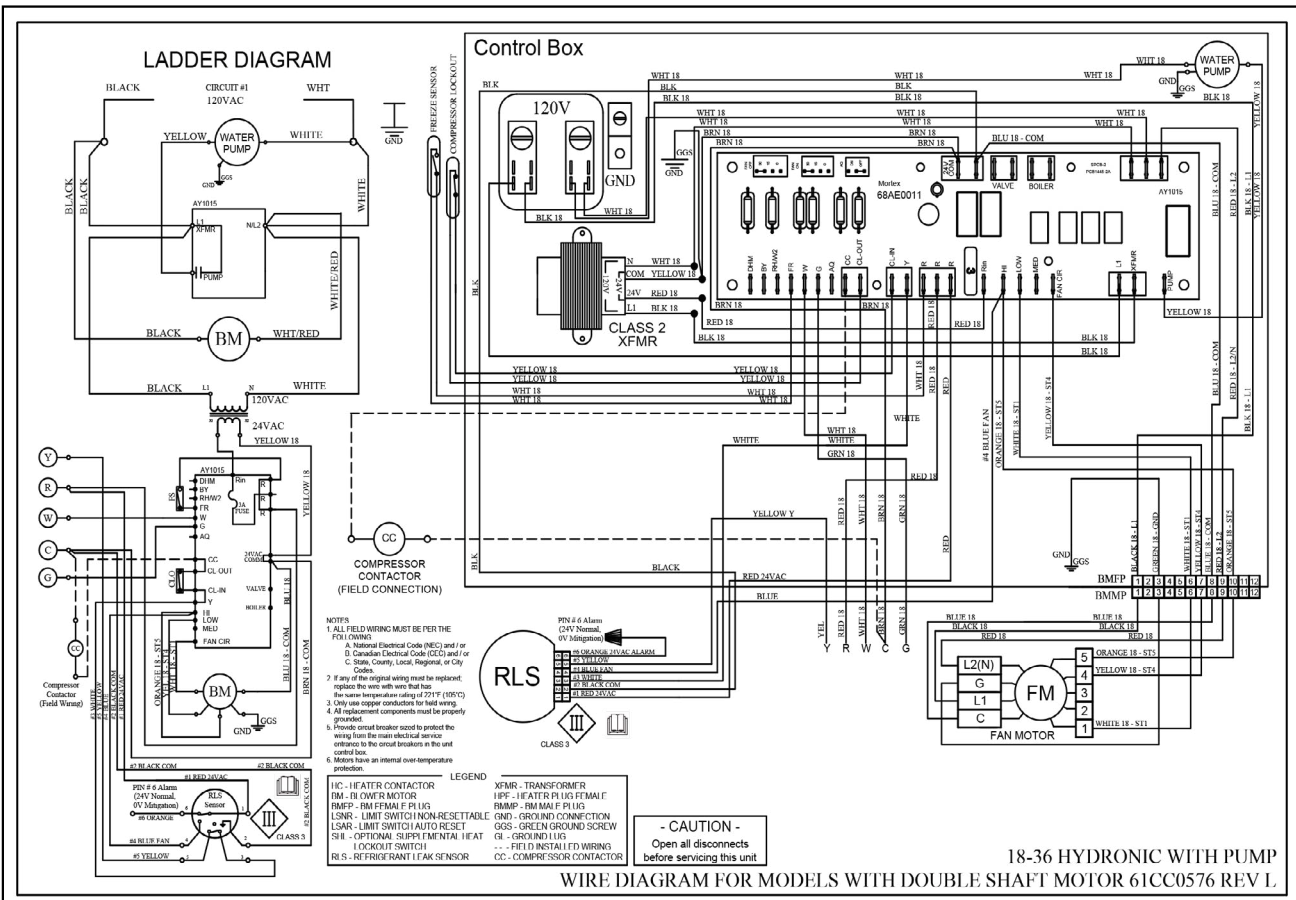
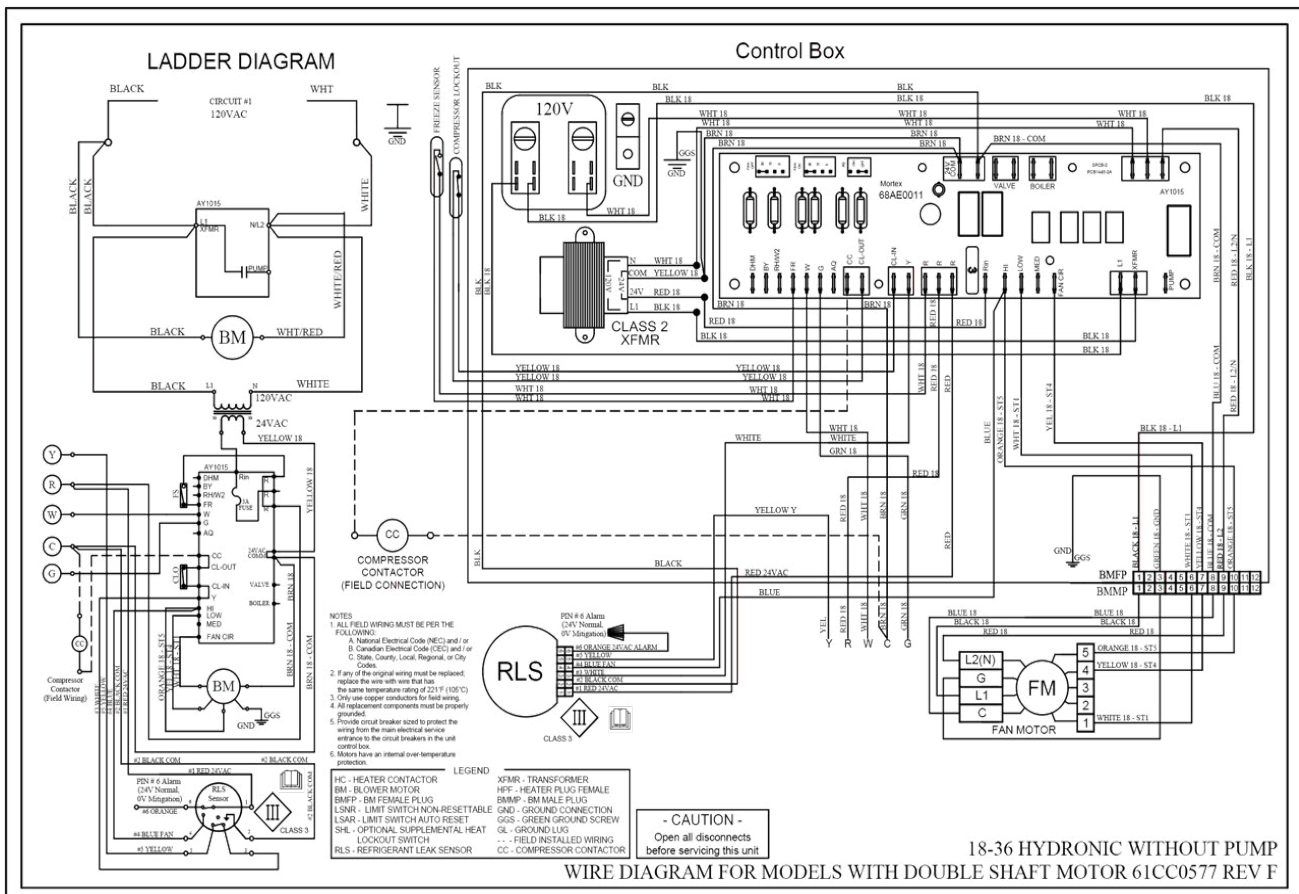

Figure 36: HE\*2/HE\*4 – Hydronic Heat With Pump – Constant Torque Motor



**Figure 37: HE\*2/HE\*4 – Hydronic Heat No Pump – Constant Torque Motor**

**SECTION 15: MINIMUM CONDITIONED SPACE AND AIR FLOW TABLES**

Total System Refrigerant Charge (kg)	Total System Refrigerant Charge (oz)	Total System Refrigerant Charge (lb)	Min. Area of Conditioned Space (m <sup>2</sup> )	Min. Area of Conditioned Space (ft <sup>2</sup> )	Min. Air-Flow (meter <sup>3</sup> /hr)	Min. Air-Flow (liter/s)	Min. Air-Flow (CFM)
1.776 kg or less	62.6 oz or less	3.91 lb or less	No Minimum	No Minimum	No Minimum	No Minimum	No Minimum
1.78	63	3.92	5.47	59	180	50	106
1.92	68	4.22	5.88	63	194	54	114
2.05	72	4.52	6.30	68	208	58	122
2.19	77	4.82	6.72	72	222	62	131
2.32	82	5.12	7.14	77	236	65	139
2.46	87	5.42	7.56	81	249	69	147
2.60	92	5.72	7.97	86	263	73	155
2.73	96	6.02	8.39	90	277	77	163
2.87	101	6.32	8.81	95	291	81	171
3.00	106	6.62	9.23	99	305	85	179
3.14	111	6.92	9.65	104	318	88	187
3.28	116	7.22	10.06	108	332	92	195
3.41	120	7.52	10.48	113	346	96	204
3.55	125	7.82	10.90	117	360	100	212
3.69	130	8.12	11.32	122	374	104	220
3.82	135	8.42	11.74	126	387	108	228
3.96	140	8.73	12.15	131	401	111	236
4.09	144	9.03	12.57	135	415	115	244
4.23	149	9.33	12.99	140	429	119	252
4.37	154	9.63	13.41	144	442	123	260
4.50	159	9.93	13.83	149	456	127	269
4.64	164	10.23	14.24	153	470	131	277
4.77	168	10.53	14.66	158	484	134	285
4.91	173	10.83	15.08	162	498	138	293
5.05	178	11.13	15.50	167	511	142	301
5.18	183	11.43	15.92	171	525	146	309
5.32	188	11.73	16.33	176	539	150	317
5.45	192	12.03	16.75	180	553	154	325
5.59	197	12.33	17.17	185	567	157	333
5.73	202	12.63	17.59	189	580	161	342
5.86	207	12.93	18.01	194	594	165	350
6.00	212	13.23	18.42	198	608	169	358
6.14	216	13.53	18.84	203	622	173	366
6.27	221	13.83	19.26	207	636	177	374
6.41	226	14.13	19.68	212	649	180	382
6.54	231	14.43	20.10	216	663	184	390
6.68	236	14.73	20.51	221	677	188	398
6.82	240	15.03	20.93	225	691	192	407
6.95	245	15.33	21.35	230	705	196	415
7.09	250	15.63	21.77	234	718	200	423
7.22	255	15.93	22.19	239	732	203	431
7.36	260	16.23	22.60	243	746	207	439
7.50	264	16.53	23.02	248	760	211	447
7.63	269	16.83	23.44	252	774	215	455
7.77	274	17.13	23.86	257	787	219	463
7.90	279	17.43	24.28	261	801	223	471
8.04	284	17.73	24.69	266	815	226	480
8.18	288	18.03	25.11	270	829	230	488
8.31	293	18.33	25.53	275	843	234	496
8.45	298	18.63	25.95	279	856	238	504
8.59	303	18.93	26.37	284	870	242	512
8.72	308	19.23	26.78	288	884	246	520
8.86	312	19.53	27.20	293	898	249	528
8.99	317	19.83	27.62	297	911	253	536

**TABLE 30: MINIMUM CONDITIONED SPACE AREA & AIR-FLOW FOR R-454B REFRIGERANT INSTALLATIONS**

- NOTES:** 1. Applies to fixed ducted systems with continuous air-flow or refrigerant detection systems only.  
 2. Based on LFL of 0.296 kg/m<sup>3</sup>

Total System Refrigerant Charge (kg)	Total System Refrigerant Charge (oz)	Total System Refrigerant Charge (lb)	Min. Area of Conditioned Space (m <sup>2</sup> )	Min. Area of Conditioned Space (ft <sup>2</sup> )	Min. Air-Flow (meter <sup>3</sup> /hr)	Min. Air-Flow (liter/s)	Min. Air-Flow (CFM)
1.836 kg or less	64.6 oz or less	4.04 lb or less	No Minimum	No Minimum	No Minimum	No Minimum	No Minimum
1.84	65	4.06	5.47	59	180	50	106
1.98	70	4.36	5.87	63	194	54	114
2.11	75	4.66	6.28	68	207	58	122
2.25	79	4.96	6.68	72	220	61	130
2.38	84	5.26	7.08	76	234	65	138
2.52	89	5.56	7.49	81	247	69	145
2.66	94	5.86	7.89	85	260	72	153
2.79	99	6.16	8.30	89	274	76	161
2.93	103	6.46	8.70	94	287	80	169
3.06	108	6.76	9.11	98	300	83	177
3.20	113	7.06	9.51	102	314	87	185
3.34	118	7.36	9.91	107	327	91	193
3.47	123	7.66	10.32	111	341	95	200
3.61	127	7.96	10.72	115	354	98	208
3.75	132	8.26	11.13	120	367	102	216
3.88	137	8.56	11.53	124	381	106	224
4.02	142	8.86	11.94	128	394	109	232
4.15	147	9.16	12.34	133	407	113	240
4.29	151	9.46	12.74	137	421	117	248
4.43	156	9.76	13.15	142	434	121	255
4.56	161	10.06	13.55	146	447	124	263
4.70	166	10.36	13.96	150	461	128	271
4.83	171	10.66	14.36	155	474	132	279
4.97	175	10.96	14.77	159	487	135	287
5.11	180	11.26	15.17	163	501	139	295
5.24	185	11.56	15.57	168	514	143	302
5.38	190	11.86	15.98	172	527	146	310
5.51	195	12.16	16.38	176	541	150	318
5.65	199	12.46	16.79	181	554	154	326
5.79	204	12.76	17.19	185	567	158	334
5.92	209	13.06	17.60	189	581	161	342
6.06	214	13.36	18.00	194	594	165	350
6.20	219	13.66	18.41	198	607	169	357
6.33	223	13.96	18.81	202	621	172	365
6.47	228	14.26	19.21	207	634	176	373
6.60	233	14.56	19.62	211	647	180	381
6.74	238	14.86	20.02	216	661	184	389
6.88	243	15.16	20.43	220	674	187	397
7.01	247	15.46	20.83	224	687	191	405
7.15	252	15.76	21.24	229	701	195	412
7.28	257	16.06	21.64	233	714	198	420
7.42	262	16.36	22.04	237	727	202	428
7.56	267	16.66	22.45	242	741	206	436
7.69	271	16.96	22.85	246	754	209	444
7.83	276	17.26	23.26	250	767	213	452
7.96	281	17.56	23.66	255	781	217	460
8.10	286	17.86	24.07	259	794	221	467
8.24	291	18.16	24.47	263	808	224	475
8.37	295	18.46	24.87	268	821	228	483
8.51	300	18.76	25.28	272	834	232	491
8.65	305	19.06	25.68	276	848	235	499
8.78	310	19.36	26.09	281	861	239	507
8.92	315	19.66	26.49	285	874	243	514
9.05	319	19.96	26.90	290	888	247	522

**TABLE 31: MINIMUM CONDITIONED SPACE AREA & AIR-FLOW FOR R-32 REFRIGERANT**

**NOTES: 1. Applies to fixed ducted systems with continuous air-flow or refrigerant detection systems  
2. Based on LFL of 0.306 kg/m<sup>3</sup>**