

Horizontal Air Handler Models:

HEC1 – DX COOLING W/ ELECTRIC HEAT, CASED
 HEC2 – DX COOLING W/ HOT WATER HEAT, CASED
 HEU2 – DX COOLING W/ HOT WATER HEAT, UNCASSED
 HEC2 – DX COOLING W/ HOT WATER HEAT, CASED

HEC3 – CHILLED WATER COOLING W/ ELECTRIC HEAT, CASED-4PP
 HEC4 – CHILLED WATER COOL W/HOT WATER HEAT, CASED-4P
 HEU4 – CHILLED WATER COOL W/HOT WATER HEAT, UNCASSED-4P
 HEC4 – CHILLED WATER COOL W/HOT WATER HEAT, CASED-4P

LIST OF SECTIONS - USERS INFORMATION MANUAL

1 – General.....	1	4 – Startup and Shutdown Instructions.....	5
2 – Safety.....	2	5 – Owner Maintenance.....	5
3 – Owner’s Information and Seasonal Information.....	3		

LIST OF SECTIONS -SERVICE AND MAINTENANCE MANUAL

1 – Safety.....	7	7 – Special Piping Instructions For A2L Class Flammable Refrigerants.....	24
2 – Air Handler Maintenance.....	11	8 – Refrigerant Leak Detection System & Sensor Replacement.....	24
3 – Air Handler Controls.....	13	9 – Accessories.....	26
4 – Sequence of Operation.....	15	10 – Replacement Parts.....	26
5 – Trouble Shooting.....	16	11 – Decommissioning & Disposal of the Air Handler.....	34
6 – Blower Performance.....	20		

LIST OF FIGURES

1 – Air Handler Visual Examination Check Points.....	5	11 – Refrigerant Leak Detection Sensor Location.....	12
2 – Homeowner / User Cleaning Points.....	6	12 – Component Locations - Hydronic Heat Models.....	13
3 – Louvered Ceiling Access Panel Air Filter Location.....	6	13 – Hydronic Heat Control Box – No Pump.....	13
4 – Typical 1” Disposable Air Filter.....	6	14 – Hydronic Control Board.....	13
5 – Optional Return Air Filter Grille.....	6	15 – Constant Torque Motor Terminals.....	16
6 – No Electric Heat Control Box.....	11	16 – Hydronic Control Board.....	17
7 – Electric Heat Control Box.....	11	17 – Blower Assembly.....	18
8 – Blower Assembly.....	12	18 – Blower Motor Mount Retainer Clip Removal.....	18
9 – Component Locations – Electric Heat Models.....	12	19 – HE*1/HE*3 Electric Heat Replacement Part Schematic.....	26
10 – Electric Heater Contactor.....	12	20 – HE*2/HE*4 Hydronic Heat Replacement Part Schematic.....	31

LIST OF TABLES

1 – 208/240 Volt Blower Motor FLA – Electric Heat Models.....	16	10 – HE*1/HE*3 – 18, 19, 24 - Electric Heat Replacement Parts List.....	27
2 – Constant Torque Motor Terminals – Electric Heat Models.....	17	11 – HE*1/HE*3 – 25, 30, 31 - Electric Heat Replacement Parts List.....	28
3 – 115 Volt Blower Motor FLA – Hydronic Heat Models.....	18	12 – HE*1/HE*3 – 34, 35 - Electric Heat Replacement Parts List.....	29
4 – Constant Torque Motor Terminals – Hydronic Heat Models.....	18	13 – HE*1/HE*3 – 36, 37 - Electric Heat Replacement Parts List.....	30
5 – HE*1/HE*3 Blower Performance – CFM.....	20	14 – HE*2/HE*4 – 18, 19, 24 - Hydronic Heat Replacement Parts List.....	31
6 – HE*1/HE*3 Blower Performance – Motor Amps.....	21	15 – HE*2/HE*4 – 25, 30, 31 - Hydronic Heat Replacement Parts List.....	32
7 – HE*2/HE*4 Blower Performance – CFM.....	22	16 – HE*2/HE*4 – 34, 35 - Hydronic Heat Replacement Parts List.....	32
8 – HE*2/HE*4 Blower Performance – Motor Amps.....	23	17 – HE*2/HE*4 – 35, 36 - Hydronic Heat Replacement Parts List.....	33
9 – Accessory List.....	26		

CONTACT INFORMATION

Manufactured and Distributed by:

Mortex Products Inc
 501 Terminal Rd
 Fort Worth, TX 76106

www.mortex.com

SECTION 1: GENERAL

The following list includes important facts and information regarding this air handler.

1. Electric heat air handlers are rated for 208 - 240 VAC at 60 Hz and hydronic air handlers are rated for 115 VAC at 60 Hz.
2. Air handler is not designed to be operated on a 50 Hz power supply.
3. All models are capable of cooling only and heat pump operation.
4. Air handler is designed for horizontal applications only.
5. This air handler must not be operated with the control box cover removed.
6. This air handler is listed by ETL for sale in the United States and Canada.

USERS MUST READ ALL INSTRUCTIONS IN THIS MANUAL.

THIS MANUAL MUST BE SAVED FOR FUTURE REFERENCE.



This is a safety alert symbol. When you see this symbol on labels or in manuals, be alert to the potential for personal injury. Understand and pay particular attention to the signal words **DANGER**, **WARNING**, or **CAUTION**.

DANGER: Indicates an imminently hazardous situation, which if not avoided, **will result in death or serious injury**.

WARNING: Indicates a potentially hazardous situation, which if not avoided, **could result in death or serious injury**.

CAUTION: Indicates a potentially hazardous situation, which if not avoided, **may result in minor or moderate injury**. It is also used to alert against unsafe practices and hazards involving property damage.

WARNING

FIRE OR ELECTRICAL HAZARD

Failure to follow the safety warnings exactly could result in serious injury, death, or property damage.

A fire or electrical hazard may result causing property damage, personal injury or loss of life.

Do not store or use gasoline or other flammable vapors and liquids in the vicinity of this air handler or any other appliance.

WARNING

Any adjustment, service or maintenance by the homeowner and/or user may create a condition where the operation of the product could cause personal injury or property damage.

Only qualified service personnel, a contractor, or an installer may refer to the service and maintenance section of this manual for assistance or for additional service or repair information on this air handler.

CAUTION

This product requires periodic routine maintenance and cleaning of the exterior surfaces by the homeowner or user to remove dust and debris. Any additional service must be performed by qualified personnel. This air handler must be serviced and maintained as specified in these instructions and/or to any applicable local, state, and national codes including, but not limited to building, electrical, and mechanical codes.

DANGER

Do not use this air handler if any part has been under water. A flood damaged air handler is extremely dangerous. Attempts to use the air handler can result in a fire. A qualified contractor, installer, or service agency must be contacted to inspect the air handler for any water damage and replace all components, control system parts, or electrical parts that have been damaged. If enough damage is present, the air handler may need to be replaced.

WARNING

FIRE OR ELECTRICAL HAZARD

Servicing heating/cooling equipment can be hazardous due to electrical components.

Only trained and qualified personnel can service or repair heating/cooling equipment. The homeowner must never try to perform service, repair or maintenance on this air handler.

Untrained service personnel can perform only basic maintenance functions such as cleaning of exterior surfaces and replacing the air filters only!

Observe all precautions in the manuals and on the attached labels when working on this air handler.

WARNING

RISK OF FIRE

This unit is equipped with a refrigerant leak detection system for safety and with electrically powered safety measures. To be effective, the unit must be electrically powered at all times after installation, other than when servicing.

SAFETY REQUIREMENTS

1. This air handler must be kept clear and free of combustible materials, gasoline and other flammable vapors and liquids.
2. Never store flammable materials of any kind near this airhandler. Gasoline, solvents and other volatile liquids should be stored only in approved containers outside the home. These materials vaporize easily and are extremely dangerous.
3. Insulating materials may be combustible. The air handler must be kept free and clear of insulating materials. The air handler area must be examined when installed in an insulated space or when insulation is added to be sure that the insulation material has been kept away from the air handler.
4. Follow the instructions exactly as shown in **Section 4: Startup and Shutdown Instructions** in this manual to properly start up or shut down this air handler. If overheating occurs, turn off the power to the air handler and contact a qualified contractor, installer, or service agency.
5. If overheating occurs, turn off the power to the air handler and contact a qualified contractor, installer, or service company.

6. Never store cleaning materials such as bleaches, detergents, chemicals can cause corrosion of the air handler sheet metal, electric heaters, blower and electrical controls.
7. Never use the area around the air handler as a storage area for items which could block or obstruct the normal air flow to the air handler or the space around the air handler. The flow of air is required for safe and proper operation. Never block or obstruct air openings used for ventilation and cooling of the air handler electrical components.
8. Refer to the air handler rating plate for the air handler model number for requirements for safe operation.
9. Provide adequate clearance for service access to the control box, electric heating elements, hydronic coil, and blower.
10. Failure to carefully read and follow all instructions in this manual can result in malfunction of the air handler which can cause death, personal injury, and/or property damage.
11. If the air handler is installed in a residential garage, it must be installed so that the electric heaters are located not less than 18 inches above the floor. The air handler must be located or protected to avoid physical damage by vehicles
12. These instructions cover minimum requirements and conform to existing national standards and safety codes. In some cases, these instructions exceed certain local codes and ordinances, especially those who have not kept up with changing modular home and residential home construction practices. These instructions are to be followed and are the minimum requirement to perform service or repairs on this air handler.
13. Installation, servicing and maintenance must only be performed by qualified service personnel that are licensed by the state to install, service, and repair HVAC equipment and those who have successfully completed a course in handling, installing, commissioning, maintenance, servicing, repairing, decommissioning, and disposal of equipment using a flammable refrigerant offered by an accredited national training organization or the manufacturer of the equipment.
14. This air handler is for use at elevations of 10,000 ft (3,048m) or less.
15. This air handler is not to be used by persons (including children) with reduced physical, sensory or mental capabilities, or lack of experience and knowledge, unless they have been given supervision or instruction concerning use of this air handler by a person responsible for their safety. Children must not be allowed to play with this air handler.

 **WARNING**

Do not use Methanol water or Ethanol in any systems operating above 40°F as the flash point specified for these chemicals is only 54°F.

 **WARNING**

Minimum Allowable Operating Temperatures – Water/Brine:
Water = 36°F (2.22°C)
Brine Solution = 3.2°F (-16°C)
Maximum Allowable Operating Temperatures – Water/Brine:
Water = 180°F (82.22°C)
Brine Solution = 40°F (4.44°C)

How The Air Handler Works – Heating Cycle

Electric Heat Models - Heating Cycle

When the thermostat calls for heat on an electric heat model, 24 VAC is sent through the limit controls to the heater contactor coil. The contactor electrical contacts close which sends 208 - 240 VAC to the electric heating elements causing them to get hot. The indoor fan motor is then energized on the selected heating speed tap and the circulating blower draws cool air from the living space, passes it across the heater elements, and pushes the warmed air through the duct work into the living space. When the thermostat is satisfied, the electric heating elements and indoor fan motor are de-energized. The heating cycle has ended and the air handler is in the stand-by mode until the thermostat initiates the next call for heat.

Hydronic Heat Models - Heating Cycle

When the thermostat calls for heat on a hydronic heating model, 24 VAC is sent to the "W" terminal on the electronic hydronic control board. If the air handler is equipped with a water pump, the control board will energize the pump causing hot water to flow through the hot water coil which causes the coil to get hot. The indoor fan motor is energized on the heating speed tap (speed tap connected to the LOW terminal on the hydronic control board) after the selected "ON" time delay and the circulating blower draws cool air from the living space, passes it across the hot water coil and pushes the warmed air through the duct work into the living space. When the thermostat is satisfied, the circulating pump is de-energized and the blower is also de-energized after the selected "OFF" time delay. The heating cycle has ended and the air handler is in the stand-by mode until the thermostat initiates the next call for heat

Electric and Hydronic Heat Models - Cooling Cycle

When the thermostat calls for cooling, 24 VAC is sent to the compressor contactor in the outdoor unit causing it to close which energizes the compressor and the outdoor fan motor.

The indoor fan motor is energized on the selected cooling speed tap after the selected "ON" time delay ("ON" time delay on hydronic heat models only) and the circulating blower draws air from the living space, passes it across the cold refrigerant coil in the air handler and pushes the cooled air through the duct work into the living space. When the thermostat is satisfied, the compressor, outdoor fan motor, and indoor blower motor are de-energized. Hydronic heat models have a selected blower motor "OFF" delay. The cooling cycle has ended and the air handler is in the stand-by mode until the thermostat initiates the next call for cooling. now in the stand-by mode awaiting the next call for cooling.

Electric and Hydronic Heat Models – Heat Pump Heating Cycle

When the thermostat calls for the heat pump heating mode, 24 VAC is sent to the compressor contactor in the outdoor unit causing it to close which energizing the compressor and the outdoor fan motor. The position of the reversing valve in the outdoor unit is switched to the heating mode causing the flow of the refrigerant to heat the refrigerant coil inside the air handler. The indoor fan motor is energized on the selected speed tap (same as the cooling mode) after the selected "ON" time delay ("ON" time delay on hydronic heat models only) and the circulating blower draws air from the living space, passes it across the warm refrigerant coil in the air handler, and pushes the warmed air through the duct work into the living

space. When the thermostat is satisfied, the compressor, outdoor fan motor, and indoor fan motor are de-energized. Hydronic heat models have a selected blower motor "OFF" delay. The heating cycle has ended and the air handler is in the stand-by mode until the thermostat initiates the next call for heat.

While Homeowner or User is Away

The air handler is equipped with safety shutoff devices which are designed to prevent the air handler from overheating in case of a malfunction. If the blower motor fails, the heating system will cycle on the safety shutoff devices while the temperature inside the home continues to drop. Water pipes will freeze once the temperature falls below 32°F.

If the homeowner or user is planning to be away for an extended period of time, someone should be asked to check on the home every day, especially when the outside temperature is expected to fall below 35°F, to ensure the air handler is operating properly and to prevent water pipes from freezing.

If Air Handler Fails to Operate Properly

If any abnormalities are observed while the air handler is operating normally, perform the following checks:

1. Check the setting on the thermostat to make sure the thermostat is set above the room temperature in the heating mode or below the room temperature in the cooling mode.
2. Check to see if the electrical power is turned on at the circuit breakers in the main electrical panel (circuit breaker box) or check to make sure the air handler service disconnect ON/OFF switch is turned to the ON position.
3. Make sure the air filters are clean, return grilles clean, are not obstructed, and supply air registers are open.

If the cause of the malfunction is not obvious, the homeowner or user must not attempt to repair the air handler. Call a qualified service company to repair the air handler.

Annual Inspection and Servicing of Air Handler

If the air handler gives any indication of improper operation, the homeowner should call a qualified service technician to inspect, diagnose, and correct the problem. It is strongly recommended that the air handler be inspected and serviced by a qualified service technician annually, preferably at the start of each heating season. The technician can identify potential problems and make corrections before trouble develops. Preventative maintenance of this type will allow the air handler to operate with minimal concerns to the homeowner for many years.

The service technician should perform the following checks during the annual inspection.

1. Confirm the physical support of the air handler is sound with no sagging.
2. Confirm there are no loose fasteners.
3. Confirm the condensate drain lines and hot water lines (hydronic models) are not leaking or sagging.
4. Confirm the air handler casing and condensate drain pan have no obvious signs of deterioration from rust or corrosion.
5. Confirm the return and supply duct connections are physically sound and are sealed to the air handler casing.
6. Operate the air handler in all modes to assure proper functioning.

Warranty and Responsibilities

It is the responsibility of the homeowner to make certain the air handler has been properly installed and adjusted to operate properly.

The manufacturer warrants the air handler to be free from defects in material or workmanship for a stated time in the warranty agreement. The manufacturer is not be responsible for any repair costs to correct problems due to improper setup, improper installation, improper adjustments, installing parts or components that are not listed for use with this air handler, improper operating procedures by the user, or repairs performed by the homeowner or user.

Some specific examples of service calls that are excluded from warranty reimbursement are:

1. Correcting faulty ductwork (too few ducts, ducts too small, leaking ducts, etc.) that was causing insufficient airflow.
2. Correcting electrical wiring problems in the supply wiring to the air handler.
3. Resetting circuit breakers or service disconnect switches used for servicing.
4. Correcting problems caused by installation and operation of the outdoor unit or air quality device not approved for use with this air handler.
5. Adjusting or calibrating the thermostat.
6. Correcting problems caused by construction debris which has been drawn into the air handler.
7. Replacing fuses.
8. Correcting problems caused by dirty air filters.
9. Correcting problems caused by return or supply air restrictions.

Before installation of the air handler, the homeowner or user should work with the installer to gain a good understanding of what will and will not be covered under the warranty to prevent future misunderstanding.

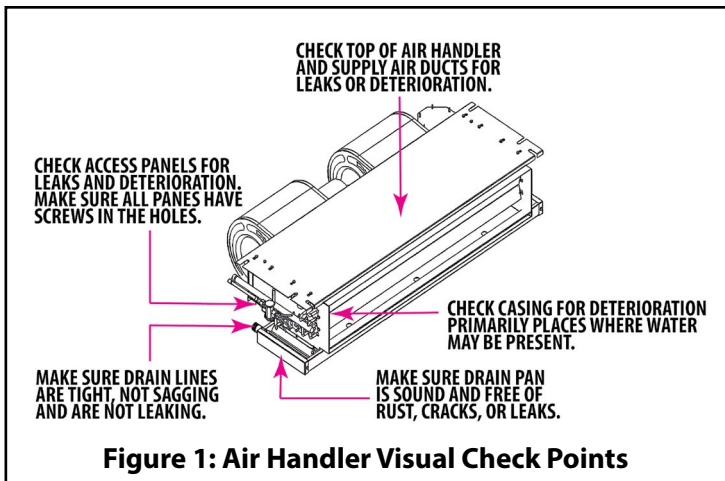

Figure 1: Air Handler Visual Check Points

! WARNING

AIR HANDLERS WITH ELECTRIC HEATERS

Should cycling of the electric heater over-temperature limit switches occur, turn the circuit breakers to the air handler in the main electrical panel (circuit breaker box) to the OFF position and call a qualified service company to troubleshoot and repair the air handler. Do not allow the electric heaters to cycle on the limit switches for an extended period of time.

When to Call For Service Assistance

Providing the service company with information about the air handler in advance of their service call will often result in the repairs being completed sooner. This includes the model number, serial number, and a description of the problem being experienced. This information will enable the service company to possibly identify the source of the problem prior to the service call and arrive with the correct parts to fix the problem.

SERVICE AGENCY INFORMATION

Fill in Below

MODEL NUMBER: _____

SERIAL NUMBER: _____

SERVICE COMPANY: _____

ADDRESS: _____

TELEPHONE (DAYTIME): _____

TELEPHONE (EMERGENCY) _____

SECTION 4: STARTUP AND SHUTDOWN INSTRUCTIONS

! WARNING

Failure to follow the following Start-Up and Shut-Down instructions exactly may result in a fire causing property damage, personal injury, and/or loss of life.

A. BEFORE OPERATING: Check around perimeter of the air handler to make sure there are no flammable materials in the area. If flammable materials or flammable vapors are smelled or otherwise detected, do not turn the power to the air handler on until the vapors have been ventilated and removed from the

area around the air handler.

- B. CHECK THE FURNACE:** Visually check the air handler for loose screws and access panels that may be missing or have fallen off.
- C. CHECK DUCT CONNECTIONS:** Visually check the connections of the air ducts to the air handler to make sure there are no gaps or holes and that the ducts are securely fastened to the air handler and sealed.

Turning On / Starting the Air Handler

1. **STOP!** Read the safety information above before proceeding.
2. Set the thermostat HEAT/COOL switch to the OFF position and FAN switch to the AUTO position.
3. Turn on the electrical power to the air handler at the main electrical panel (circuit breaker box).
4. Turn the air handler electrical service disconnect switch for the air handler to the ON position.
5. Close the ceiling access panel if it is open.
6. Set the thermostat HEAT/COOL switch, FAN switch, and temperature set point to the desired settings.

Shutting Down / Turning Off the Air Handler

1. Set the thermostat HEAT/COOL switch to the OFF position and FAN switch to the AUTO position.
2. If the air handler is operating at the time the thermostat is turned to the OFF position, wait until the air handler has completed its cycle and has shut down before turning off the power to the air handler.
3. Turn the air handler electrical service disconnect switch to the OFF position.
4. Turn off the electrical power to the air handler at the main electrical panel (circuit breaker box).

SECTION 5: OWNER MAINTENANCE

All air handlers need annual maintenance in order to operate properly. The annual service must be performed by qualified service personnel. The homeowner is expected to perform general cleaning of the exterior surfaces and replacement of the air filters. Air filters must be checked every month and replaced as needed. The air filter will either be located in a louvered ceiling access panel underneath the air handler or in a return air filter grille located on a wall or ceiling near the air handler. Figure 3 shows a louvered ceiling access panel and Figure 5 shows a return air filter grille.

Louvered Ceiling Access Panel Air Filter Replacement

Most horizontal air handlers have the filters in a louvered ceiling access panel located in the ceiling below the air handler. The louvered ceiling access panel has an air filter rack designed to accept 1" thick standard air filters. Follow these easy steps to replace the air filters.

1. Follow the procedure "Shutting Down/Turning Off the Air handler" in the **Section 4: Startup and Shutdown Instructions** section of this manual.
2. Remove the thumb screws on the louvered ceiling access panel. Be careful when removing the last thumb screw as the panel can swing down quickly and cause injury.
3. Allow the panel to rotate downward and hand vertically.
4. Remove the dirty air filters from the filter racks.

NOTE: The air filters are disposable. Do not attempt to clean the filters and reuse them.

5. Clean any dust or debris from both sides for the louvers and around the area where the filters are placed before the new air filters are installed.

- Place new standard disposable filters into both filter racks that are the same size as the filters that were removed.

NOTE: Make sure the flow arrows on the filters are pointing away from the louvers in the ceiling panel.

- Lift the louvered ceiling access panel into the closed position and tighten the thumb screws until the panel is securely fastened to the louvered ceiling access panel frame assembly.
- Follow the **“Turning On / Starting the Air Handler”** in the **Section 4: Startup and Shutdown Instructions** section of these instructions.

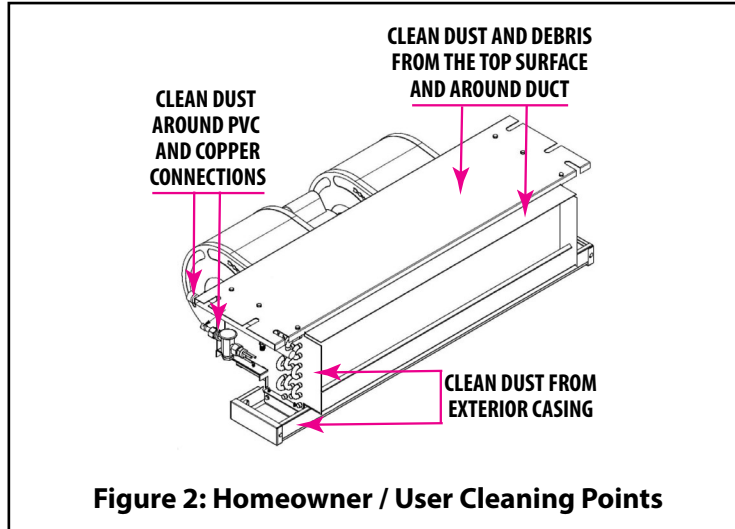

Figure 2: Homeowner / User Cleaning Points

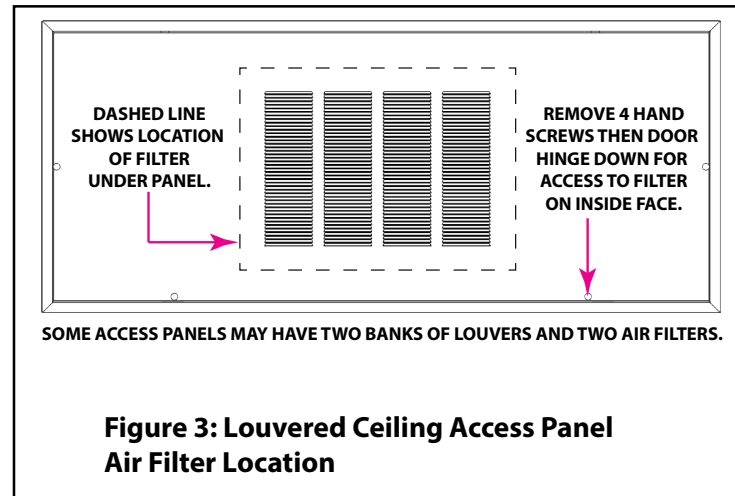

Figure 3: Louvered Ceiling Access Panel Air Filter Location

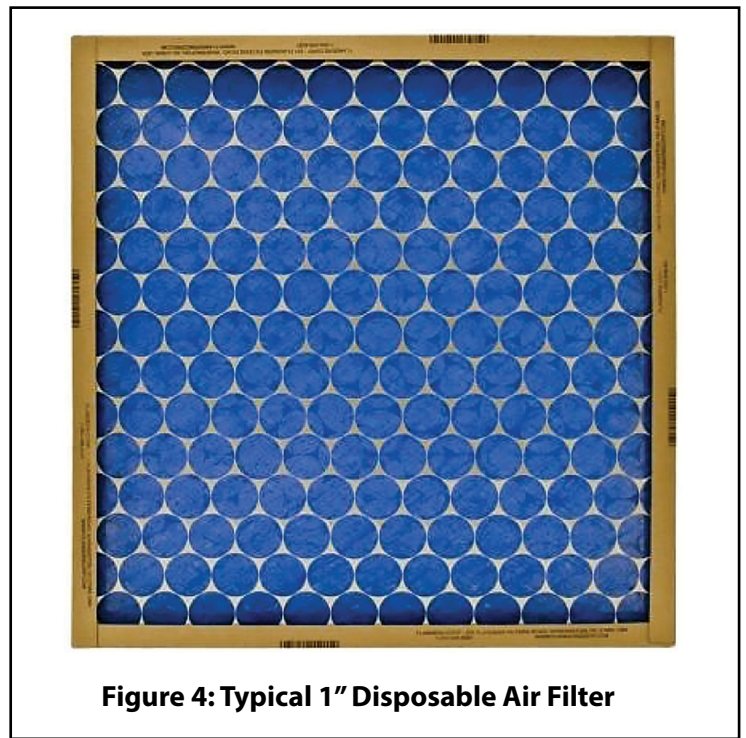

Figure 4: Typical 1” Disposable Air Filter

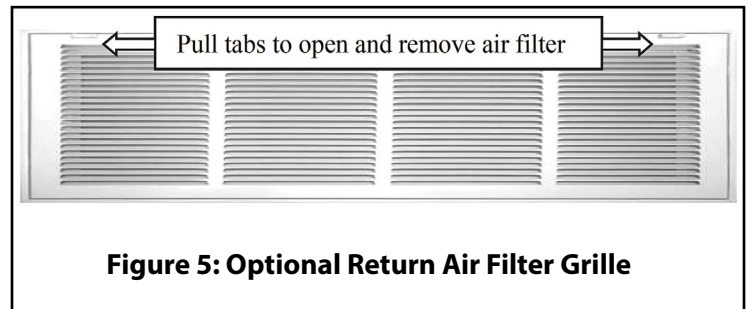

Figure 5: Optional Return Air Filter Grille

Air Filter Replacement – Optional Return Air Filter Grille

Follow the steps below to replace the air filter in a return air filter grille.

- Unlike with a louvered ceiling access panel, replacing the air filter in a return air filter grille located away from the air handler can be done safely without disconnecting the electrical power to the air handler.
- Remove the thumb screws or pull out on the pull tabs located on the filter grille.
- Pull the grille outward (wall mount) or downward (ceiling mount).
- Remove the air filter from the grille frame or rack. The air filter is disposable. Do not attempt to clean the filter and reuse it.
- Clean any dirt or debris around the grille and frame where the air filter is located. Be careful not to use any small vacuum cleaner parts or any small brushes to clean inside the filter frame and around the filter rack. These parts or brushes can fall off or drop into the return duct causing a restriction of the return air flow.
- Place a new disposable filter of the same size as was removed into the grille frame or rack.
- Push the grille closed and tighten the thumb screws or push them pull tabs inward to secure the grille to the frame.

NOTE: Make sure the flow arrow on the new filter is pointing away from the grille louvers.

⚠ WARNING

IMPACT HAZARD

Use extreme caution when removing the ceiling access panel thumb screws that secure the panel to the frame assembly. Once the thumb screws have been removed, the ceiling access panel can swing down very quickly if not adequately supported and can strike a person standing underneath it.

The ceiling panel louvers can also have sharp edges which can cut hands or fingers. The use of gloves is recommended when handling the ceiling access panel to prevent injury.

SERVICE AND MAINTENANCE MANUAL

SECTION 1: SAFETY

This section has been designed to assist a qualified service agency in performing service and maintenance on this air handler.

The homeowner or the air handler user must never attempt to perform any service or maintenance on the air handler when it involves the removal or adjustment of any parts and/or components.

WARNING

The manufacturer or distributor will not be responsible for any repairs due to removal of parts or improper parts changes, improper maintenance, improper adjustments or improper modifications to this air handler that were performed by the homeowner and/or the air handler user.

The manufacturer will not be responsible if the homeowner and/or air handler user use this section of the instructions in an attempt to perform maintenance or repairs to the air handler. This practice is very dangerous and may result in a fire causing property damage, personal injury, loss of life and/or will void the air handler warranty.



This is a safety alert symbol. When you see this symbol on labels or in manuals, be alert to the potential for personal injury. Understand and pay particular attention to the signal words **DANGER**, **WARNING**, or **CAUTION**.

DANGER: Indicates an imminently hazardous situation, which if not avoided, will result in death or serious injury.

WARNING: Indicates a potentially hazardous situation, which if not avoided, could result in death or serious injury.

CAUTION: Indicates a **potentially** hazardous situation, which if not avoided, may result in minor or moderate injury. It is also used to alert against unsafe practices and hazards involving property damage.

CAUTION

This air handler must be serviced and maintained as specified in these instructions and/or to any applicable local, state, and national codes including, but not limited to building, electrical, and mechanical codes.

WARNING

ALWAYS SHUT OFF ELECTRICITY AT THE DISCONNECT SWITCH OR TURN OFF THE CIRCUIT BREAKERS IN THE MAIN ELECTRICAL ENTRANCE BEFORE PREFORMING ANY SERVICE ON THE AIR HANDLER.

WARNING

FIRE OR ELECTRICAL HAZARD

Failure to follow the safety warnings exactly could result in serious injury, death, or property damage.

A fire or electrical hazard may result causing property damage, personal injury or loss of life.

SAFETY REQUIREMENTS

1. The air handlers with electric heaters have a 2-pole terminal block to connect the electrical supply circuit. Make sure you check each electrical circuit with a meter to be sure Insulating materials may be combustible. The air handler must be kept free and clear of insulating materials.
2. Follow the instructions exactly as shown in **SECTION 4: Startup and Shutdown in the User Information Manual** on page 5 to properly Startup or Shutdown this air handler.
3. Make sure all moving parts have come to a complete stop before attempting to perform any work the air handler. Moving parts can cause serious injury if clothing or body parts get caught in the moving part.

WARNING

ELECTRICAL SHOCK, FIRE HAZARD

Failure to follow the safety warnings or improper servicing could result in dangerous operation, serious injury, property damage, and/or death.

WARNING

FIRE HAZARD

NEVER PLACE A JUMPER BETWEEN "R" & "W"

Placing jumper wire between the RED and WHITE thermostat wires at the air handler in order to override the thermostat and energize the heater elements is an extremely dangerous practice that can result in damage to the thermostat, dangerous operation, serious injury, property damage and/or death.

5. Repair and maintenance to electrical components shall include initial safety checks and component inspection procedures. If a fault exists that could compromise safety, then no electrical supply shall be connected to the circuit until it is satisfactorily dealt with. If the fault cannot be corrected immediately but it is necessary to continue operation, an adequate temporary solution shall be used. This shall be reported to the owner of the equipment so all parties are advised.
6. Initial safety checks shall include:
 - that capacitors are discharged: this shall be done in a safe manner to avoid possibility of sparking;
 - that no live electrical components and wiring are exposed

- while charging, recovering or purging the system;
 - that there is continuity of earth bonding.
7. Check that cabling will not be subject to wear, corrosion, excessive pressure, vibration, sharp edges or any other adverse environmental effects. The check shall also take into account the effects of aging or continual vibration from sources such as compressors or fans.
 8. Installation, servicing and maintenance must only be performed by qualified service personnel that are licensed by the state to install, commission, service, repair, decommission, and dispose of HVAC equipment and those who have successfully completed a course in handling, installing, maintenance, servicing, and repairing equipment using a flammable refrigerant offered by an accredited national training organization or the manufacturer of the equipment.
 9. Sealed electrical components must be replaced when they fail.
 10. Intrinsically safe components must be replaced when they fail.

Maximum Operating Temperature for Heat Pump Applications

For heat pump applications, the maximum outdoor temperature recommended by the manufacturer while the system is operating in the heating mode is 70°F/23.9°C.

Proper Safe Working Procedures for Equipment Using Flammable Refrigerants

Prior to beginning work on systems containing flammable refrigerants, safety checks are necessary to ensure that the risk of ignition is minimized. For repair to the refrigerating system, the following steps must be completed prior to conducting work on the system.

1. Work shall be undertaken under a controlled procedure so as to minimize the risk of a flammable gas or vapour being present while the work is being performed.
2. All maintenance staff and others working in the local area shall be instructed on the nature of work being performed. Work in confined spaces shall be avoided.
3. The area shall be checked with an appropriate refrigerant detector prior to and during work, to ensure the technician is aware of potentially toxic or flammable atmospheres. Ensure that the leak detection equipment being used is suitable for use with all applicable refrigerants (i.e.: non-sparking, adequately sealed or intrinsically safe).
4. If any hot work is to be conducted on the refrigerating equipment or any associated parts, appropriate fire extinguishing equipment shall be available to hand. Have a dry powder or CO₂ fire extinguisher adjacent to the charging area.
5. No person performing work in relation to a refrigerating system which involves exposing any pipe work shall use any sources of ignition in such a manner that it may lead to the risk of fire or explosion. All possible ignition sources, including cigarette smoking, should be kept sufficiently far away from the site of installation, repairing, removing and disposal, during which refrigerant can possibly be released to the surrounding space. Prior to work taking place, the area around the equipment is to be surveyed to make sure that there are no flammable hazards or ignition risks. "No Smoking" signs shall be displayed.
6. Ensure that the area is in the open or that it is adequately ventilated before breaking into the system or conducting any hot work. A degree of ventilation shall continue during the period that the work is performed. The ventilation should safely disperse any released refrigerant and preferably expel it externally into the atmosphere.

7. Where electrical components are being changed, they shall be fit for the purpose and to the correct specification. At all times the manufacturer's maintenance and service guidelines shall be followed. If in doubt, consult the manufacturer's technical department for assistance.
8. The following checks shall be applied to installations using flammable refrigerants:
 - the actual refrigerant charge is in accordance with the room size within which the refrigerant containing parts are installed;
 - marking to the equipment continues to be visible and legible. Markings and signs that are illegible shall be corrected;
 - refrigerating pipe or components are installed in a position where they are unlikely to be exposed to any substance which may corrode refrigerant containing components, unless the components are constructed of materials which are inherently resistant to being corroded or are suitably protected against being so corroded.

9. Detection of Flammable Refrigerants

Under no circumstances shall potential sources of ignition be used in the searching for or detection of refrigerants leaks. A halide torch (or any other detector using a naked flame) shall not be used.

The following leak detection methods are deemed acceptable for all refrigerant systems.

Electronic leak detectors may be used to detect refrigerant leaks but, in the case of flammable refrigerants the sensitivity may not be adequate, or may need re-calibration. (Detection equipment shall be calibrated in a refrigerant-free area.)

Ensure that the detector is not a potential source of ignition and is suitable for the refrigerant used.

Leak detection equipment shall be set at a percentage of the LFL of the refrigerant and shall be calibrated to the refrigerant employed, and the appropriate percentage of gas (25 % maximum) is confirmed.

Leak detection fluids are also suitable for use with most refrigerants, but the use of detergents containing chlorine shall be avoided as the chlorine may react with the refrigerant and corrode the copper pipe-work.

NOTE: Examples of leak detection fluids are:

- bubble method,
- fluorescent method agents.

If a leakage of refrigerant is found which requires brazing, all of the refrigerant shall be recovered from the system, or isolated (by means of shut off valves) in a part of the system remote from the leak. Removal of refrigerant shall be according to Step 10 below.

10. Removal and Evacuation

When breaking into the refrigerant circuit to make repairs or for any other purpose, conventional procedures shall be used. However, for flammable refrigerants, it is important that best practice be followed since flammability is a consideration. The following procedure shall be adhered to:

- safely remove refrigerant following local and national regulations;
- evacuate;
- purge the circuit with inert gas (optional for A2L);

- evacuate (optional for A2L);
- continuously flush or purge with inert gas when using flame to open circuit; and
- open the circuit.

The refrigerant charge shall be recovered into the correct recovery cylinders if venting is not allowed by local and national codes. For appliances containing flammable refrigerants, the system shall be purged with oxygen-free nitrogen to render the appliance safe for flammable refrigerants. This process might need to be repeated several times. Compressed air or oxygen shall not be used for purging refrigerant systems. (Also see **Refrigerant Recovery Requirement** below.

For appliances containing flammable refrigerants purging shall be achieved by breaking the vacuum in the system with oxygen-free nitrogen and continuing to fill until the working pressure is achieved, then venting to atmosphere, and finally pulling down to a vacuum (optional for A2L). This process shall be repeated until no refrigerant is within the system (optional for A2L). When the final oxygen-free nitrogen charge is used, the system shall be vented down to atmospheric pressure to enable work to take place.

The outlet for the vacuum pump shall not be close to any potential ignition sources, and ventilation shall be available.

11. Charging Procedures

In addition to conventional charging procedures, the following requirements shall be followed.

- Ensure that contamination of different refrigerants does not occur when using charging equipment. Hoses or lines shall be as short as possible to minimize the amount of refrigerant contained in them.
- Cylinders shall be kept in an appropriate position according to the instructions.
- Ensure that the refrigerating system is earthed prior to charging the system with refrigerant.
- Label the system when charging is complete (if not already).
- Extreme care shall be taken not to overfill the refrigerating system.

Prior to recharging the system, it shall be pressure-tested with the appropriate purging gas. The system shall be leak-tested on completion of charging but prior to commissioning. A follow up leak test shall be performed prior to leaving the site.

12. Refrigerant Recovery Requirements

When removing refrigerant from a system, either for servicing or decommissioning, it is recommended good practice that all refrigerants are removed safely.

When transferring refrigerant into cylinders, ensure that only appropriate refrigerant recovery cylinders are employed. Ensure that the correct number of cylinders for holding the total system charge is available. All cylinders to be used are designated for the recovered refrigerant and labeled for that refrigerant (i.e. special cylinders for the recovery of refrigerant). Cylinders shall be complete with pressure-relief valve and associated shut-off valves in good working order. Empty recovery cylinders are evacuated and, if possible, cooled before recovery occurs.

The recovery equipment shall be in good working order with a set of instructions concerning the equipment that is at hand and shall be suitable for the recovery of the flammable

refrigerant. If in doubt, the manufacturer should be consulted. In addition, a set of calibrated weighing scales shall be available and in good working order. Hoses shall be complete with leak-free disconnect couplings and in good condition.

The recovered refrigerant shall be processed according to local legislation in the correct recovery cylinder, and the relevant waste transfer note arranged. Do not mix refrigerants in recovery units and especially not in cylinders.

If compressors or compressor oils are to be removed, ensure that they have been evacuated to an acceptable level to make certain that flammable refrigerant does not remain within the lubricant. The compressor body shall not be heated by an open flame or other ignition sources to accelerate this process. When oil is drained from a system, it shall be performed safely.

13. Commissioning of the System

- Ensure that the floor area is sufficient for the refrigerant charge or that the ventilation duct is assembled in a correct manner.
- Connect the pipes and perform a leak test before charging with refrigerant.
- Check safety equipment before putting into service.

14. Maintenance of the Air Handler

- Ensure sufficient ventilation at the repair place.
- Be aware that malfunction of the equipment may be caused by refrigerant loss and a refrigerant leak is possible.
- Discharge capacitors in a way that won't cause any spark. The standard procedure to short circuit the capacitor terminals usually creates sparks.
- Reassemble sealed enclosures accurately. If seals are worn, replace them.
- Check safety equipment before putting the air handler into service.

15. Repair of the Air Handler

- Ensure sufficient ventilation at the repair place.
- Be aware that malfunction of the equipment may be caused by refrigerant loss and a refrigerant leak is possible.
- Discharge capacitors in a way that won't cause any spark.
- When brazing is required, the following procedures shall be performed in the following order:
 - Safely remove the refrigerant following local and national regulations. If the recovery is not required by national regulations, drain the refrigerant to the outside. Take care that the drained refrigerant will not cause any danger. In doubt, one person should guard the outlet. Take special care that drained refrigerant will not float back into the building;
 - Purge the refrigerant circuit with oxygen free nitrogen;
 - Evacuate the refrigerant circuit;
 - Remove parts to be replaced by cutting or brazing.
 - Purge the braze point with nitrogen during the brazing procedure required for repair.
 - Perform a leak test before charging with refrigerant.
- Reassemble sealed enclosures accurately. If seals are worn, replace them.
- Check safety equipment before putting system back into service.

16. Decommissioning of the Air Handler (Refer to Section 11 of this manual for additional information)

- If the safety is affected when the equipment is put out of

service, the refrigerant charge shall be removed before decommissioning.

- Ensure sufficient ventilation at the equipment location.
- Be aware that malfunction of the equipment may be caused by refrigerant loss and a refrigerant leak is possible.
- Remove the refrigerant. If the recovery is not required by national regulations, drain the refrigerant to the outside. Take care that the drained refrigerant will not cause any danger. In doubt, one person should guard the outlet. Take special care that drained refrigerant will not float back into the building.

17. Disposal of the Air Handler (Refer to Section 11 of this manual for additional information)

- Ensure sufficient ventilation at the working place.
- Remove the refrigerant. If the recovery is not required by national regulations, drain the refrigerant to the outside. Take care that the drained refrigerant will not cause any danger. In doubt, one person should guard the outlet. Take special care that drained refrigerant will not float back into the building.
- When flammable refrigerants are used,
 - evacuate the refrigerant circuit.
 - purge the refrigerant circuit with oxygen free nitrogen.

 **WARNING**

FIRE HAZARD

For air handlers using A2L refrigerants connected via an air duct system to one or more rooms with a floor area less than shown in the "Minimum Conditioned Space and Airflow" tables (Tables 30 and 31) found in the installation instructions for this air handler, those rooms shall be without continuously operating open flames (e.g.: an operating gas appliance) or other potential ignition sources (e.g.: an operating electric heater, hot surfaces). A flame-producing device may be installed in the same space if the device is provided with an effective flame arrest.

 **WARNING**

FIRE HAZARD

For air handlers using A2L refrigerants connected via an air duct system to one or more rooms, only auxiliary devices approved by the air handler manufacturer or declared suitable with the refrigerant shall be installed in connecting ductwork.

 **WARNING**

FIRE HAZARD

For air handlers using A2L REFRIGERANTS connected via an air duct system to one or more rooms, auxiliary devices which may be a potential ignition source shall not be installed in the duct work. Examples of such potential ignition sources are hot surfaces with a temperature exceeding 1290°F (700°C) and electric switching devices.

 **WARNING**

RISK OF FIRE – FLAMMABLE REFRIGERANT APPLICATIONS

The ductwork connected to this air-handler shall not contain an ignition source.

Auxiliary devices which may be a potential ignition source shall not be installed in the duct work. Examples of such potential ignition sources are hot surfaces with a temperature exceeding 1292°F (700°C) and electric switching devices.

Only auxiliary devices approved by the air-handler manufacturer or declared suitable with the refrigerant shall be installed in connecting ductwork.

 **WARNING**



RISK OF FIRE

Do not use means to accelerate the defrosting process or to clean, other than those recommended by the manufacturer.

The appliance shall be stored in a room without continuously operating ignition sources (e.g.: open flames, an operating gas appliance, or an operating electric heater).

Do not pierce or burn.

Be aware that refrigerants may not contain an odor.

 **WARNING**

RISK OF FIRE – FLAMMABLE REFRIGERANT APPLICATIONS

If any refrigerating circuit contains more than 62.6 oz (1.776 kg) of R-454B refrigerant or more than 64.6 oz (1.836 kg) of R-32 refrigerant, an unventilated area where the air-handler using a flammable refrigerant is installed shall be so constructed that should any refrigerant leak, it will not stagnate and create a fire or explosion hazard.

If the air duct system connected to one or more rooms with an area less than the minimum conditioned space floor area shown in "Minimum Conditioned Space and Airflow Tables" (Tables 30 and 31) found in the installation instructions for this air handler based on the total system refrigerant charge, that room shall be without continuously operating open flames (e.g.: an operating gas appliance) or other potential ignition sources (e.g.: an operating electric heater, hot surfaces). A flame-producing device may be installed in the same space if the device is provided with an effective flame arrest.

SECTION 2: AIR HANDLER MAINTENANCE

The interior sections of the air handler must be cleaned and adjusted by a qualified service contractor prior to the start of each heating or cooling season. The following items must be checked:

1. The blower wheel and motor for excessive dirt.
2. The electric heaters for wear, damage or corrosion.
3. The electrical components for excessive dust, dirt, wear, or deterioration.
4. The supply air duct system for excessive dust, dirt or debris.
5. The return air duct system for excessive dust, dirt or debris.
6. All electrical wiring for wear, insulation cracks and/or damage.
7. Check the air conditioning evaporator coil for dust, debris or damage.
8. Condensate drain pan for proper drainage to prevent water backup into the air handler.
9. The air handler casing and all interior sheet metal panels or dividers.

Air Handler Cleaning Procedure

1. Follow the instructions in **SECTION 4: Startup and Shutdown** of the **User Information** portion of this manual to properly shut down the air handler.
2. Open the ceiling access panel by removing the thumb screws.

CAUTION: Be very careful when removing the last thumb screw as the panel can swing down quickly and cause injury.

3. Blower Removal
 - a) Disconnect the wires connected to the motor controller terminal block.

NOTE: Write down the terminal block position for each wire before disconnecting the wires.

- b) Remove the screws that secure the blower assembly to the air handler chassis located on each side and at the top center of the blower mounting plate.
 - c) Grasp the blower assembly and lift it up while pulling out on the bottom. Lower the blower assembly out of the blower compartment and set assembly on a table or the floor.
4. Use a vacuum cleaner and a small brush to remove any dirt and debris from the blower and evaporator coil compartments.
 5. Check the condensate drain pan for any debris and check to see if the drain pan is draining properly by pouring water into it.
 6. Remove any excess water that may have spilled from checking the condensate drain drainage.
 7. Pour ½ cup of chlorine bleach in the drain pipe to kill any fungus that may be growing inside the pipe to prevent the condensate drain from plugging up.
 8. Check in the area in the discharge of the blowers where the heater elements are located and remove any dust, dirt or debris from around the heater elements. Be careful not to damage the heater elements with the vacuum hose or the brush.
 9. Check both blower wheels for dust and debris. Use the brush and the vacuum cleaner to remove any dust or debris from the wheels. Be careful not to accidentally move or remove the blower wheel balance weights located on the wheel blade. If any weight is moved or removed, the blower wheel will vibrate. If the blower wheel is vibrating, it must be replaced.
 10. Check the blower motor for dust and debris. Clean the openings in the motor housing. These openings are for cooling the motor. Plugged motor housing openings will cause the motor to run hotter than normal and will shorten the life of the motor.
 11. Clean dust in the supply and return ducts with a brush and

vacuum cleaner as far as can be reached. If the ducts have an excessive amount of dust, dirt or debris, recommend that the homeowner or user call a professional duct cleaning service to properly clean the duct system.

NOTE: Dust is flammable and can cause a fire.

12. Check and clean any dust, dirt, or debris from the controls and surfaces inside the control box. Dust or dirt on the components can cause the controls to overheat and fail prematurely.
13. Check the indoor coil for dust or dirt buildup. If dirty, use a non-corrosive spray specifically designed to clean air-conditioning coils. Remove the electric heater elements (electric heat models) before cleaning the coil so the coil cleaner doesn't get on the elements. Follow the procedure found later on this page for removing the electric heater elements. After the heater elements have been removed (if applicable), spray the entire surface of the coil. Rinsing the coil is unnecessary as the condensate will rinse the coil when the system is operated in the cooling mode.
14. Reinstall the electric heater elements as described in the procedure for reinstalling the electric heaters on this page.
15. Lift the blower assembly into place while pushing in on the bottom and pulling down to set the blower mounting plate into place.
16. Replace the screws on the blower mounting plate that were removed in Step 3.
17. Reconnect the blower motor leads that were disconnected in Step 3.
18. Reattach the motor guard to the control box and reinstall the control box cover.
19. Close the ceiling access panel and secure the panel with the thumb screws.
20. Follow the instructions in **SECTION 4: Startup and Shutdown** of the **User Information** portion of this manual to properly start the air handler.

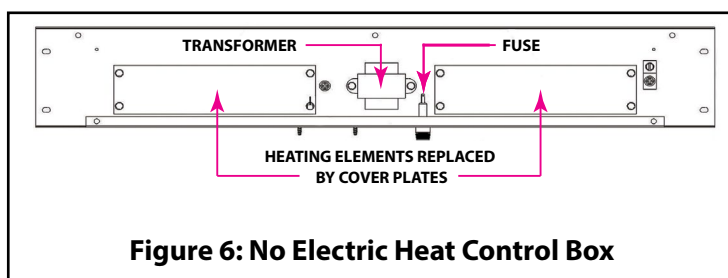

Figure 6: No Electric Heat Control Box

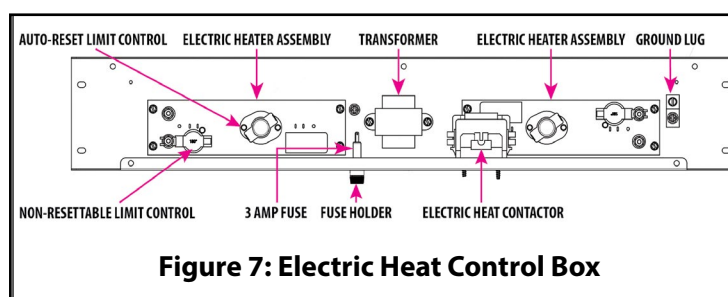

Figure 7: Electric Heat Control Box

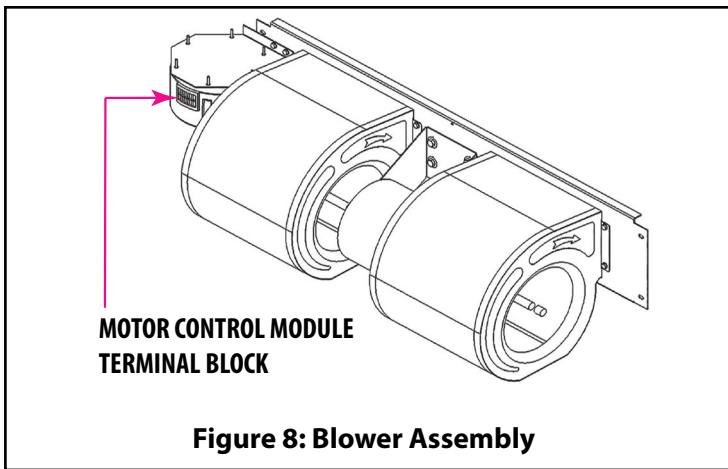

Figure 8: Blower Assembly

Removing and Reinstalling the Electric Heater Elements

1. Follow the instructions in **SECTION 4: Startup and Shutdown** of the **User Information** portion of this manual to properly shut down the air handler.
2. Open the ceiling access panel by removing the thumb screws.

CAUTION: Be very careful when removing the last thumb screw as the panel can swing down quickly and cause injury.

3. Remove the control box cover.
4. Unplug the blower motor female plug (BMFP) from the mating plug located on the control box.
5. Disconnect the electrical supply wires and ground wire from the terminal block and ground lug. Remove the strain relief that is securing these wires and remove the wires from the control box.
6. Remove the 5 screws that secure the control box to the air handler and remove the control box. The electric heater elements are attached to the control box and will come out with the control box.

NOTE: Take care not to damage the heaters when removing the control box.

7. Remove the wires from the heater element screw terminals.
8. Remove the screws that secure the auto-reset and non-resettable limit controls to the heater element mounting plate and remove the limit controls (See Figure 7).
9. Remove the 4 screws that secure the heater element to the control box and remove the element.
10. Insert the new heater element into the control box and secure it with the screws that were removed in Step 9.
11. Install the auto-reset and non-resettable limit controls into the appropriate holes in the heater element mounting plate and secure them with the screws removed in Step 8.
12. Reconnect the wiring that was removed in Step 7.
13. Reinstall the control box and secure it to the air handler with the screws that were removed in Step 6.

NOTE: Take care not to damage the heaters when installing the control box.

14. Reconnect the wiring that was removed in Steps 4 and 5.
15. Reinstall the control box cover.
16. Close the ceiling access panel and secure it to the frame assembly with the thumb screws.
17. Follow the instructions in **SECTION 4: Startup and Shutdown** of the **User Information** portion of this manual to properly start the air handler.

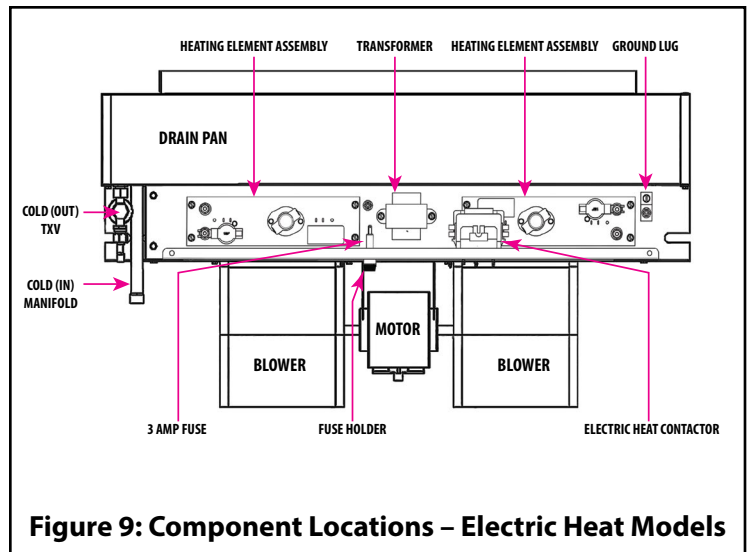

Figure 9: Component Locations – Electric Heat Models

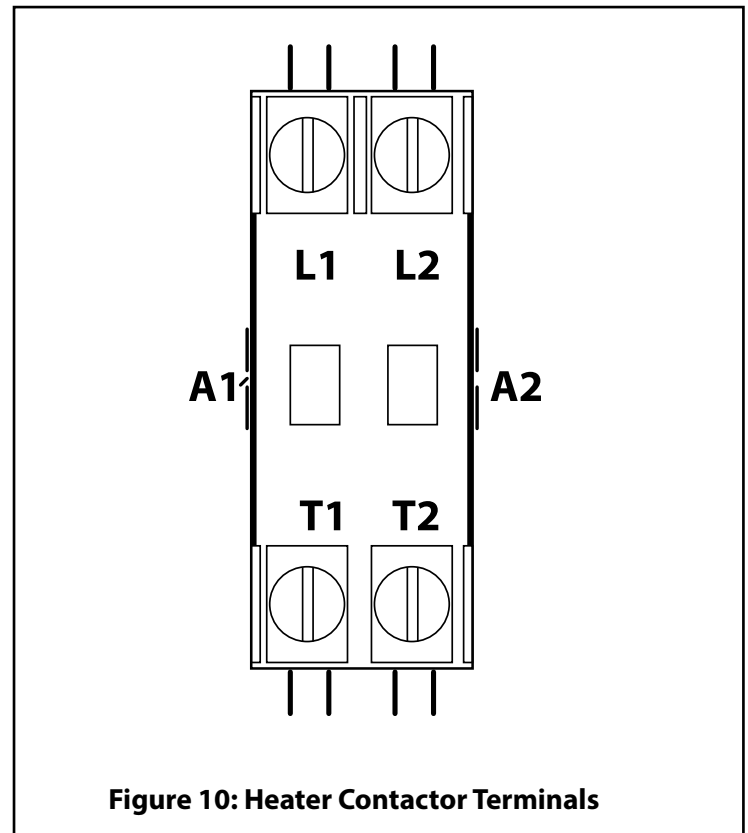

Figure 10: Heater Contactor Terminals

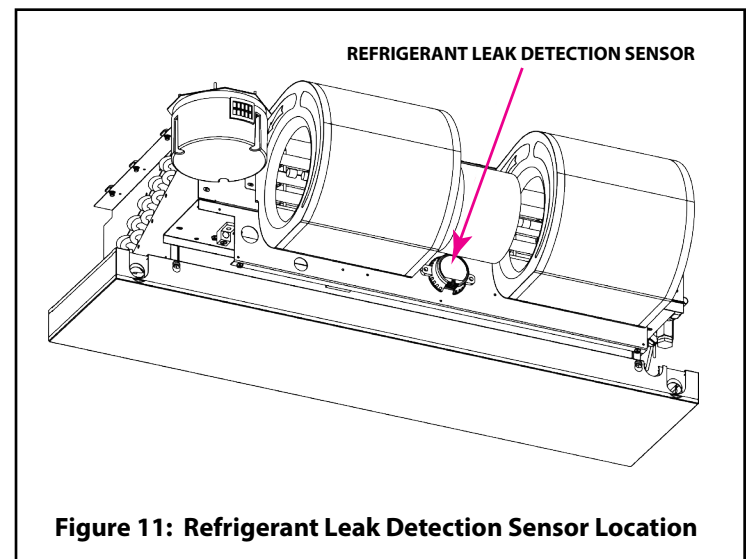

Figure 11: Refrigerant Leak Detection Sensor Location

SECTION 3: AIR HANDLER CONTROLS

Electric Heat Models

This section explains how the electric heat air handler controls operate. Refer to Figures 6 - 11 for component locations.

- 1. Limit Controls** – Each electric heater element has a limit control directly in front of it to sense overheating of the element and open if the temperature gets above the set point of the limit control, the heater cycles until the cause for the overheating is corrected..
- 2. Heater Contactors**–The electric heater contactor turns the heater elements on and off and is controlled by the thermostat. On a call for heat, 24 VAC is sent to the contactor's 24 VAC coil which closes the contactor's electrical contacts and energizes the heater elements. When the call for heat has been satisfied, 24 VAC is removed from the contactor's 24 VAC which opens the contactor's electrical contacts and de-energizes the heater elements. The 5kW and 10kW heaters have a single contactor and the 15kw and 20kw heaters have two contactors.
- 3. Transformer**– The transformer is used to step down voltage from 208/240 VAC to 24 VAC which is used for the system's control circuit.
- 4. Refrigerant Leak Detection System** – A refrigerant sensor is attached to a bracket located below the blower motor. Should a refrigerant leak occur in the coil itself or tubing, the sensor will detect the leak and energize the indoor blower and disable the outdoor unit compressor. The leak detection system consists of a single device that houses a refrigerant sensor and internal relays. Refer to Figure 11 for the location of the refrigerant leak sensor.

Hydronic Heat Models

This section explains how the hydronic heat air handler controls operate. Refer to Figures 11 - 14 for component locations.

- 1. Transformer** – The transformer is used to step down voltage from 208/240 VAC to 24 VAC which is used for the system's control circuit.
- 2. Hydronic Control Board** – The hydronic control board is factory installed and controls the operation of air handler components.
- 3. Water Pump:** The water pump power leads are connected to the "PUMP" terminals on the hydronic control board. When there is a call for heat, a 24 VAC signal from the thermostat "W" terminal to the "W" terminal on the hydronic control board energizes the pump and starts the flow of water to the heating coil. When the call for heat has been satisfied, the pump is de energized and the flow of water to the coil stops. The air handler is now in the standby mode awaiting the next call for heat.
- 4. Blower Motor:** The hydronic control board has 3 speed terminals for the blower motor. These terminals are energized with 115 VAC for models with PSC motors or 24 VAC for models with constant torque motors. The "HI" terminal is energized in the normal cooling mode and the "MED" terminal is energized in the cooling de-humidification mode. The "LOW" terminal is energized in the heating mode. The FAN CIR terminal is energized in the continuous mode when there is no call for cooling or heating. The hydronic control board has two jumper pins for selecting the blower motor "ON" and "OFF" delays. The blower "ON" and "OFF" delays can be set independently at 0, 15, or 30 seconds.
- 5. Refrigerant Leak Detection System** – A refrigerant sensor is located below the blower motor. Should a refrigerant leak occur in the coil itself or tubing, the sensor will detect the leak

and energize the indoor blower and disable the outdoor unit compressor. The leak detection system consists of a single device that houses a refrigerant sensor and internal relays. Refer to Figure 11 for the location of the refrigerant leak sensor.

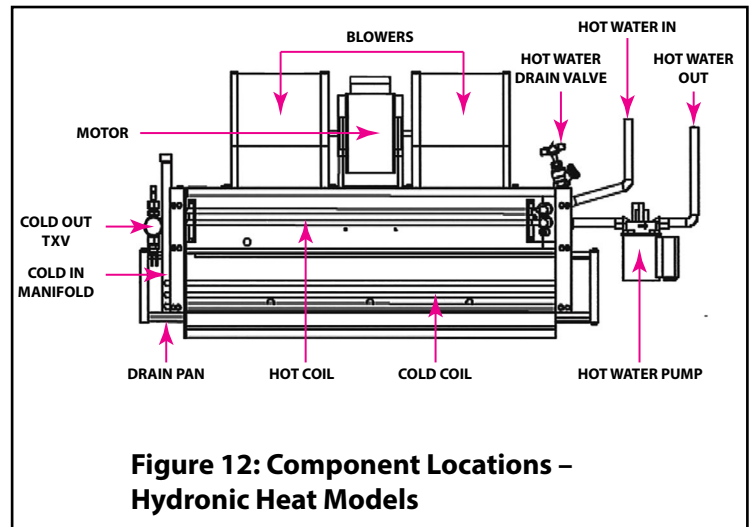

Figure 12: Component Locations - Hydronic Heat Models

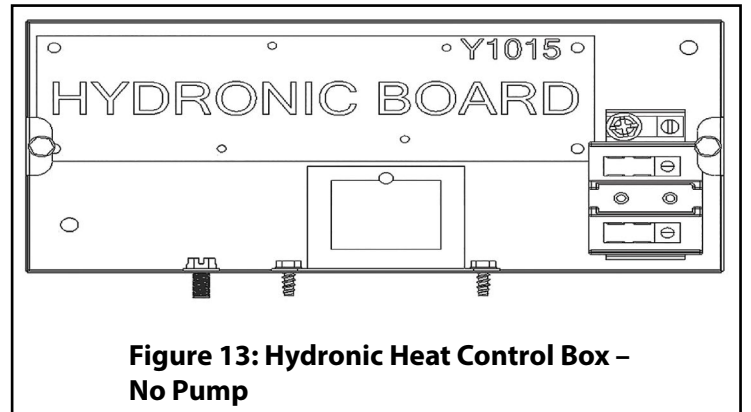

Figure 13: Hydronic Heat Control Box - No Pump

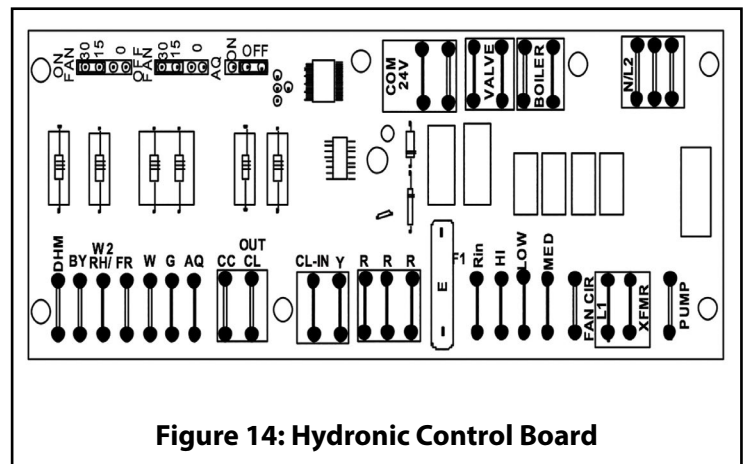

Figure 14: Hydronic Control Board

Hydronic Control Board Terminals and Descriptions

The terminals and functions are explained below.

Line Voltage Terminals

- L1** – Supply Voltage (115 VAC) to the control
- L2** – Supply Neutral (115 Neutral) to the control
- XFMR and L2** – 115 VAC supply to transformer
- Pump and L2** – 115 VAC to the water pump

24 VAC Terminals

- Rin** – 24 VAC supply from the transformer
- 24V COM** – 24 VAC common from the transformer
- R** – Fused 24 VAC output connections
- Y** – Connect to the thermostat Y terminal
- CC** – Connect **CC** and **24V COM** to the compressor contactor on the outdoor unit.
- CLin & Clout** – connections for compressor lockout switch on hot water coil or jumper wire.
- AQ** – 24 VAC from aquastat temperature switch
- G** – 24 VAC from thermostat G terminal
- W** – 24 VAC from thermostat W terminal
- FR** – 24 VAC from freeze protection switch
- RH/W2** – 24 VAC from thermostat W2 terminal
- BY** – 24 VAC from the priority switch on tank less heater
- DHM** – 24 VAC from thermostat DHM terminal
- VALVE** – 24 VAC and 24V COM to zone valve
- BOILER** – switch, connect to "T" terminals on boiler aquastat

Hydronic Control Board Terminal Functions

- HI & COM** – 24 VAC cooling speed tap to blower motor
- MED & COM** - 24 VAC dehumidification speed tap to blower motor
- LOW & COM** - 24 VAC heating speed tap to blower motor
- FAN CIR & COM** – 24 VAC continuous fan speed tap to blower motor

CLin and Clout – These terminals must be connected to transfer 24 VAC from the Y terminal to the CC terminal. When the compressor lockout switch is used, the switch is secured to the water coil. The two yellow wires are connected to the CLin and the Clout terminals. When the temperature of the water coil reaches 38°F, the switch opens which de-energizes the CC terminal on the control board. When the water temperature has risen above 42°F the compressor lockout switch will close. The control will send 24 VAC to the CC terminal on the control board.

NOTE: If the compressor lockout switch is not used, place a jumper wire between CLin and Clout to get 24 VAC from the Y terminal to the CC terminal. The indoor blower will not be energized in the cooling mode until the CC terminal has 24 VAC at the terminal.

AQ – The aquastat switch is placed on the hot water line exiting side of the air handler coil. The aquastat is connected to the R terminal and the AQ terminal on the control board. The AQ jumper pin shown in Figure 14 must be in the ON position to use this feature. When there is a call for heat (24 VAC on the W terminal) and the water line temperature reaches the aquastat switch setting, the switch will close sending 24 VAC to the AQ terminal turning on the blower motor. The blower motor will not energize until the aquastat switch is closed. When the call for heat has been satisfied, the indoor blower will be de-energized after the selected OFF delay.

VALVE – There are two terminals used to power a 24 VAC zone valve or solenoid valve. The terminal closest to the 24V COM terminals is a 24VAC common terminal to the valve. See Figure 14. The other terminal is the 24 VAC output to the valve. When there are 24 VAC

to the W terminal the control board will send 24 VAC to the valve terminals. The VALVE terminals de-energize when the 24 VAC is removed from the W terminal.

BOILER - There are two terminals that are connected to a switch. The terminals do not output any voltage and are dry contacts. The BOILER switch is designed to be connected to the "T" terminals on a boiler aquastat to energize the boiler when the control board has a call for heat (24 VAC on W).

G – When 24 VAC is placed on the G terminal the control will energize the indoor blower by the FAN CIR terminal with NO delay. When the 24 VAC signal has been removed from the G terminal, the indoor blower will be de-energized with NO delay.

If there is a call for heat (24 VAC on the W terminal) while 24 VAC is present on the G terminal, the control will energize the pump, valve and boiler and the indoor fan motor will be de-energized. The indoor fan motor will be energized by the LOW terminal after the selected ON delay. When the call for heat has been satisfied, the control will de-energize the valve, pump and boiler and the indoor fan motor will switch to the FAN CIR speed terminal after the selected OFF delay.

If there is a call for cooling while there is 24 VAC on the G terminal, the control will switch the indoor blower speed to the HI terminal. When the call for cooling has been satisfied, the control will switch the indoor blower back to the FAN CIR speed.

W – When 24 VAC is present on the W terminal, the control will energize the pump, valve and boiler and the indoor fan will be energized by the LOW terminal after the selected ON delay. When the call for heat has been satisfied, the control will de-energize the valve, pump and boiler and the indoor fan motor will be de-energized after the selected OFF delay.

FR – The FR terminal energizes the control board freeze protection. The freeze protection switch is secured to the water coil. The two white wires are connected to the R terminal and to the FR terminal on the control board. When the temperature of the coil is below 38°F, the freeze protection switch closes and sends 24 VAC to the FR terminal. The control will energize the pump, valve, boiler, and indoor fan motor on the LOW speed terminal. The control will not energize the indoor fan motor even when there is a call for heat with 24 VAC on the W terminal. When the water temperature has risen above 42°F, the freeze protection switch will open. The control will de-energize the pump, valve, boiler, and LOW speed terminal providing there is not a call for heat. If there is a call for heat at the time FR is de-energized, the pump, valve and boiler will remain ON and the control will keep the LOW speed terminal energized.

W2/RH- When W2/RH is energized, the control will de-energize the LOW speed terminal and energize the MED speed terminal with no delay. When the W2 Terminal is de-energized the MED speed terminal will be de-energized and the LOW speed terminal will be energized with no delays.

BY – Bypass terminal is used when the heating and domestic hot water system are managed with the same tankless hot water system. The domestic water line has a normally open flow switch that is connected to the R and the BY terminals on the control board. When the domestic water flow switch detects the flow of water, the switch closes sending 24 VAC to the BY terminal. The control will de-energize the PUMP, VALVE, BOILER terminals and the indoor blower. When the domestic water flow has stopped the domestic water flow switch will open and the PUMP, VALVE, and

BOILER terminals will resume normal operation. The indoor blower will be energized after the selected ON delay.

Y – When there is a call for cooling (24 VAC is placed on the Y terminal), the control will energize the indoor blower with the HI terminal after the selected ON delay. When the call or cooling has been satisfied, the indoor blower will be de-energized after the selected OFF delay.

DHM – Dehumidification mode can be used with any thermostat that has dehumidification terminal. The dehumidification terminal must send 24 VAC to the DHM terminal on the control board to put the control in dehumidification mode. When 24 VAC is present on the Y terminal (call for cooling) and there is 24 VAC is present on the DHM terminal, the control will energize the indoor blower with the MED terminal after the selected ON delay as long as there is a motor speed tap connected to the MED terminal. If the control has the indoor blower operating on the HI terminal when 24 VAC is placed on the DHM terminal, the control will de-energize the HI terminal and energize the MED terminal with no delays. If the control has the indoor blower motor operating on the MED speed terminal when 24 VAC is removed from the DHM terminal, the control will energize the HI terminal and de-energize the MED terminal with no delay.

IMPORTANT: A motor speed tap wire must be connected to the MED terminal for the dehumidification mode to work. Otherwise, the indoor blower will be de-energized upon call for dehumidification while the compressor is operating, resulting in the indoor coil freezing up.

SECTION 4: SEQUENCE OF OPERATION

Continuous Blower – Electric Heat Models

Moving the thermostat FAN switch to the “ON” position (continuous fan mode) completes the circuit between “R” and “G” terminals and sends 24 VAC to the GREEN air handler pigtail which is connected to the selected indoor blower motor speed tap for the cooling and continuous fan modes. The indoor blower will operate continuously until the thermostat FAN switch is moved to the “AUTO” position.

Continuous Blower – Hydronic Heat Models

Moving the thermostat FAN switch to the “ON” position (continuous fan mode) completes the circuit between “R” and “G” terminals and sends 24 VAC to the “G” terminal on the hydronic control board. Once the selected control board blower “on-delay” is complete, the control board will send 24 VAC to the “FAN CIR” terminal on the control board and energize the motor’s continuous fan speed (motor speed tap 1). The indoor blower will operate continuously until the thermostat FAN switch is moved to the AUTO position.

Intermittent Blower – Cooling Cycle – Electric Heat Models

When the thermostat FAN switch is in the AUTO position and the thermostat calls for cooling, the circuit between the “R”, “Y” and “G” terminals is completed and sends 24 VAC to the YELLOW air handler pigtail wire which is connected to the selected indoor blower motor speed tap for the cooling mode. If no refrigerant leak is detected by the air handler’s refrigerant leak sensor, 24 VAC is also sent to the outdoor unit which closes the compressor contactor coil and energizes the compressor and outdoor fan motor. When the thermostat is satisfied, the circuit between “R”, “Y” and “G” opens which will de-energize the blower motor, compressor, and the outdoor fan motor. The system is now in the standby mode awaiting the next cooling cycle.

Intermittent Blower – Cooling Cycle Hydronic Heat Models

When the thermostat FAN switch is in the AUTO position and the thermostat calls for cooling, the circuit between the “R”, “Y” and “G” Terminals is completed and sends 24 VAC to the G and Y terminals on the hydronic control board. The hydronic control board sends 24 VAC to the “Y” thermostat wire to the outdoor unit which closes the compressor contactor and energizes the compressor and outdoor fan motor. The hydronic control board also energizes the indoor blower with the HI terminal after the selected ON delay.

When the thermostat is satisfied, the circuit between “R”, “Y” and “G” opens, the compressor contactor opens and the indoor blower is de-energized after the selected OFF delay. The system is now in the standby mode awaiting the next cooling cycle.

Intermittent Blower – Heating Cycle Electric Heat Models

When the thermostat FAN switch is in the AUTO position and the thermostat calls for heat, the thermostat circuit between the “R” and “W” terminals is completed. This sends 24 VAC from the “W” terminal to the WHITE air handler pigtail wire to the heater contactor coil. This signal closes the heater contactor contacts which sends 208-240 VAC to the heating elements. The selected indoor blower heating speed (WHITE wire) is energized by the 24 VAC signal from the thermostat “W” terminal to the normally closed isolation relay contacts between terminals #5 and #6 on the relay which occurs at the same time the heating elements are energized.

When the call for heat has been satisfied, the 24 VAC signal will be removed from the thermostat “W” terminal which will de-energize the heating elements and indoor blower. The air handler is now in the standby mode awaiting the next heating cycle.

Intermittent Blower – Heating Cycle - Hydronic Heat Models

When the thermostat FAN switch is in the AUTO position and the thermostat calls for heat, the thermostat circuit between the “R” and “W” terminals is completed. 24 VAC is sent from the “W” terminal on the thermostat to the hydronic control board. The hydronic control board will energize the water pump and start circulation of hot water through the water coil. The hydronic control board will also energize the indoor blower with the LOW terminal after the selected ON delay. When the call for heat has been satisfied, the “W” terminal is de-energized and the hydronic control board will de-energize the water pump and will also de-energize the indoor blower after the selected OFF delay. The air handler is now in standby mode waiting for the next heating cycle.

SECTION 5: TROUBLESHOOTING

The following checks should be made before further troubleshooting of the air handler controls when the blower does not operate or there is a no-heat or no-cooling issue. The electric heat models use relays to control the blower motor and a contactor to control the electric heater. The hydronic heat models use a hydronic control board to control the operation of all the components.

Initial Troubleshooting Checks

1. Check all circuit breakers in the main electrical panel (circuit breaker box). Make sure they are turned to the "ON" position and have not tripped.
2. Check to make sure the service disconnect switch is in the "ON" position. The service disconnect switch is often mistaken for a light switch and is turned off.
3. Check any supply line fuses that were installed during installation are not blown. Check the wiring with an ohmmeter for a short to ground. If shorted, repair the short and replace the fuse(s).
4. Check to make sure there is 24 VAC between the RED (R) air handler thermostat pigtail and ground. If 24 VAC is not present, check the low voltage in-line fuse in the air handler control box or on the hydronic control board to see if it is blown. If the fuse is not blown and there is 208-240 VAC between the transformer primary wires, replace the transformer.
5. Check to make sure there is 24 VAC between the R and C terminals of the thermostat. If 24 VAC is not present, check the low voltage wiring and connections between the air handler and the thermostat.
6. Check to make sure there is 24 VAC between the G and C terminals of the thermostat when there is a call for cooling or continuous fan and between W and C when there is a call for heat. If 24 VAC is present between the R and C terminals, but 24 VAC is not present between the C and G terminals (cooling continuous fan) or between W and C terminals (heating), replace the thermostat.
7. Check to make sure there is 24 VAC between the GREEN (G) air handler thermostat pigtail and ground when there is a call for cooling or continuous fan and between the WHITE (W) pigtail when there is a call for heat. If 24 VAC is present in either of these cases and the thermostat and transformer were found to be OK in steps 4 and 6 above, check the low voltage wiring and wiring connections between the thermostat and air handler.
8. Check all wiring connections to the air handler components to ensure they are securely connected.

TROUBLESHOOTING ELECTRIC HEAT MODELS

NOTE: Be sure to perform the Initial Troubleshooting Checks before performing the following checks.

WARNING

To avoid personal injury or property damage, make certain that the motor leads cannot contact non-insulated metal components of the unit.

WARNING

For personal safety be sure to turn the electrical power "OFF" at the main entrance (Circuit Breaker Box) and at the control box circuit breakers before attempting any service or maintenance operations. Homeowners should never attempt to perform any maintenance which requires opening the air handler control box cover.

Heating Mode Constant Torque Motor Check – Electric Heat Models

If 24 VAC is not present between the air handler WHITE thermostat pigtail and ground when the thermostat is calling for heat, check the wiring and wiring connections from the thermostat "W" terminal to the air handler WHITE thermostat pigtail. If 24 VAC is present at the WHITE thermostat pigtail, check all of the wiring and wiring connections from the WHITE thermostat pigtail to the blower motor terminal block. If 24 VAC is present between the BLUE (common) and WHITE (heating speed) wires connected to the motor terminal block (See Figure 15 and Table 2) and there is 208-240 VAC between the RED and BLACK wires connected to the N and L motor terminals, replace the motor.

Cooling/Continuous Fan Mode Constant Torque Motor Check - Electric Heat Models

If 24 VAC is present between the GREEN air handler thermostat pigtail and ground, but the blower motor is not running when there is a call for cooling or continuous fan, check all of the wiring and wiring connections between the GREEN air handler thermostat pigtail and the motor terminal block and between the heater contactor L1 and L2 terminals and the motor terminal block. If 24 VAC is present between the BLUE (common) and BLACK (cooling/continuous fan speed) wires connected to the motor terminal block and there is 208-240 VAC between the RED and BLACK wires connected to the N and L motor terminals, replace the motor.

HP	FLA
1/3	0.68
1/2	1.70

Table 1: 208 / 240 Volt Blower Motor FLA - Electric Heat Models

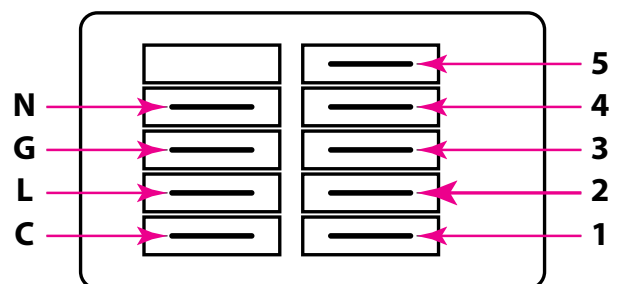

Figure 15: Constant Torque Motor Terminals

Terminal	Connection
C	Speed Tap Common - 24 VAC Common
L	Supply Voltage - 208/240 VAC Line 1
G	Ground Connection
N	Supply Voltage - 208/240 VAC Line 2
1	Low Speed Tap - 24 VAC Input
2	Medium-Low Speed Tap - 24 VAC Input
3	Medium Speed Tap - 24 VAC Input
4	Medium-High Speed Tap - 24 VAC Input
5	High Speed Tap - 24 VAC Input

Table 2: Constant Torque Motor Terminal Connections Electric Heat Models

Electric Heat Models – No Heat or Reduced Heat

Check for 24 VAC between the WHITE (W) air handler low voltage pigtail and ground when the thermostat is set to the HEAT mode and the temperature is set above the room temperature. If 24 VAC is present on the WHITE air handler pigtail, check for 208- 240 VAC between the heating elements power terminals on each heating element. If 208-240 VAC is not present at the heating element terminals, check for 24 VAC across the heater contactor coil. If 24 VAC is present across the heater contactor coil and 208-240 VAC is present between contactor terminals L1 and L2, but 208-240 VAC is not present across heater contactor terminals T1 and T2, replace the contactor. If 24 VAC is not present across the heater contactor coil, use an ohmmeter to check for continuity across the terminals of the auto-reset limit control on both heating elements. If the contacts on either limit control are open when the heating elements are cool, replace that limit control. If 208-240 VAC is present between heater contactor terminals T1 and T2, but 208-240 VAC is not present between the heater element terminals, use an ohmmeter to check for continuity across the non-resettable control limit on both heating elements. If the contacts on either non-resettable limit control are open, replace that limit control. If 208-240 VAC is present across the heating element terminals, check the current draw for each heating element. If there is no current or the current is not close to what is shown below, the heating element is defective and must be replaced.

- The electric heating element amperages are as follows:
- 3 kW Heater = 12.5 amps (Two 1.5kW Heating Elements)
- 5 kW Heater = 20.8 amps (Two 2.5kW Heating Elements)
- 6 kW Heater = 25.0 amps (Two 3.0 kW Heating Elements)
- 8 kW Heater = 33.3 amps (Two 4.0 kW Heating Elements)
- 10 kW Heater = 41.6 amps (Two 5.0 kW Heating Elements)

TROUBLESHOOTING HYDRONIC HEAT MODELS

NOTE: Be sure to perform the Initial Troubleshooting Checks before performing the following checks.

Constant Torque Motor Checks - Hydronic Heat Models

If the motor is not running when there is a call for heat, cooling, or continuous fan, check for 115 VAC between the L and N motor terminals (See Figure 15 and Table 4) and check for 24 VAC between the “COM/24V” terminal and either the “HI” (cooling), “MED” cooling/ dehumidification), “LOW” (heating), or “FAN CIR” (continuous fan) terminal on the control board (See Figure 16). If 115 VAC is present between motor terminals L and N and 24 VAC is present between the “COM/24V” terminal and either the “HI”, “MED”, “LOW”, or “FAN CIR” terminal on the control board, but the motor is

not operating, check the connections at the motor terminals and the motor connector plugs BMMP and BMFP. If these connections are secure and there is 24 VAC between the C motor terminal and any of the wires connected to terminals 1 – 5 on the motor, replace the motor. Refer to Figure 15 and Table 4 for terminal locations and definitions. If 115 VAC is present between motor terminals L and N, but 24 VAC is not present between the “COM/24V” terminal and either the “HI”, “MED”, “LOW”, or “FAN CIR” terminal on the control board when there is a call for heat, cooling, or continuous fan, replace the control board.

Hydronic Control Board Checks

If 115 VAC is not present on the L2 and N terminals on the control board, check the service disconnect switch to determine if the switch was turned to the “OFF” position. If the service disconnect switch is in the “ON” position, check the circuit breaker in the main electrical panel to see if the breaker had tripped or is in the “OFF” position. If the service disconnect switch and the breaker are in the “ON” position, check the wiring between the main electrical panel and the air handler.

If 24 VAC is present between the Rin and COM/24V terminals on the control board, but 24 VAC is not present between the R and COM/24V terminals (See Figure 15), check the fuse on the control board to see if it is blown. If 24 VAC is present between the “W” and “24V COM” terminals on the control board when there is a call for heat, check the AQ jumper to make sure it is in the “OFF” position unless it is in the “ON” position with an aquastat installed. If so equipped, check to see if the aquastat is closed when the water line is cold. If the aquastat is open when the water line is cold, replace it. If 24 VAC is present between the “W” and “24V COM” terminals on the control board when there is a call for heat and 115 VAC is not present between the L2/N and PUMP terminals on the control board, replace the control board.

If there is a call for heat and 24-VAC is present between the “W” and “24V COM” terminals on the control board and there is 24-VAC on the “R” terminals to common but the PUMP, VALVE, BOILER and blower motor are not energized, replace the control board. If the blower motor is not operating after the selected ON delay, check for 24 VAC across the LOW and COM terminal. If 24VAC is not present, replace the control board. If 24 VAC is present at the LOW terminal, check the wiring and connections from the control board to the blower motor and correct any wiring issues found. If no wiring or connection issues are found, replace the blower motor.

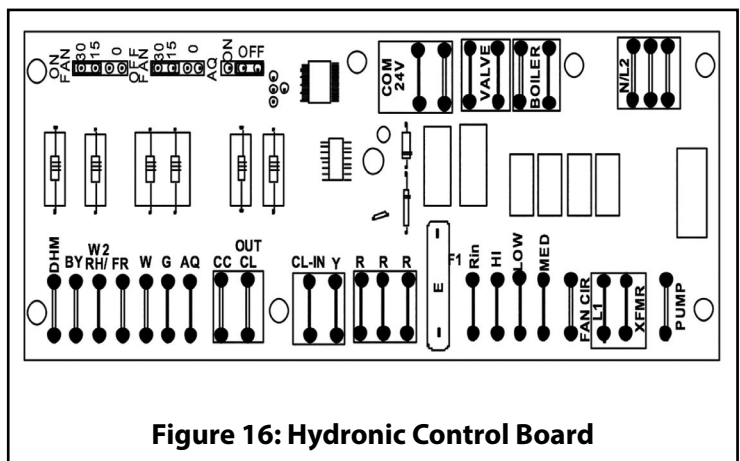

Figure 16: Hydronic Control Board

HP	FLA
1/3	1.67
1/2	3.00

Table 3: 115 Volt Blower Motor FLA Hydronic Heat Models

TERMINAL	CONNECTION
C	Speed Tap Common - 24 VAC Common
L	Supply Voltage - 115 VAC
G	Ground Connection
N	Supply Voltage - Neutral
1	Low Speed Tap - 24 VAC Input
2	Medium - Low Speed Tap - 24 VAC Input
3	Medium Speed Tap - 24 VAC Input
4	Medium - High Speed Tap - 24 VAC Input
5	High Speed Tap - 24 VAC Input

Table 4: Constant Torque Motor Terminal Connections – Hydronic Heat Models

WARNING

To avoid personal injury, take precautions to not come into contact with non-insulated electrical components.

Avoid wearing loose clothing or any items that can come in contact with moving parts, such as the blower wheel as this can cause serious personal injury.

REPLACING THE BLOWER ASSEMBLY

1. Turn off all electrical supply circuits to the air handler at the main electrical panel (circuit breaker box) and turn the local air handler service disconnect to the OFF position.
2. Loosen the ceiling access panel thumbscrews and lower access panel.
3. Disconnect the wires connected to the motor controller terminal block.

NOTE: Write down the terminal block position for each wire before disconnecting the wires.

4. Remove the screws that secure the blower assembly to the air handler chassis located on each side and at the top center of the blower mounting plate.
5. Gasp the blower assembly and lift it up while pulling out on the bottom. Lower the blower assembly from the blower compartment and set it on a table or the floor.
6. Loosen the set screws that secure the blower wheels to the motor shaft until the shaft can spin freely 360° while inside the blower wheel hub. The blower wheel set screws are located on the blower wheel hub opposite the motor.
7. Remove the motor controller mounted to the channel located on the left side of the blowers.
8. Remove the screws securing the blower housings to the blower mounting plate.
9. Set the replacement blower motor on the motor mount bracket. Place one end of the retaining clip into the notch on the motor mount bracket. Use a flat blade screwdriver and a mallet on the “U” shaped part of the retaining clip to push the clip down and

- into the notch on the other side of the bracket.
10. Place each blower housing in the correct location on the blower mount plate and secure the blower housings to the blower mounting plate with the screws removed in Step 8.
11. While facing the discharge of the blowers, center the blower wheels in the blower housings.
12. Align the set screws in the middle of the flat section of each motor shaft and tighten the set screws to secure the blower wheels to each motor shaft.
13. Attach the motor controller to the channel located on the left side of the blowers.
14. Lift the blower assembly into place inside the blower compartment and push in at the bottom.
15. Install the screws that secure the blower mounting plate to the air handler chassis that were removed in Step 4.
16. Connect the wiring removed from the motor controller terminal block that were removed in Step 3.

NOTE: Refer to the air handler wiring diagram to confirm all wiring connections are correct.

17. Turn on all electrical supply circuits to the air handler at the main electrical panel (circuit breaker box) and turn the local air handler service disconnect to the ON position.
18. Set the thermostat to the desired operating mode and temperature setpoint.

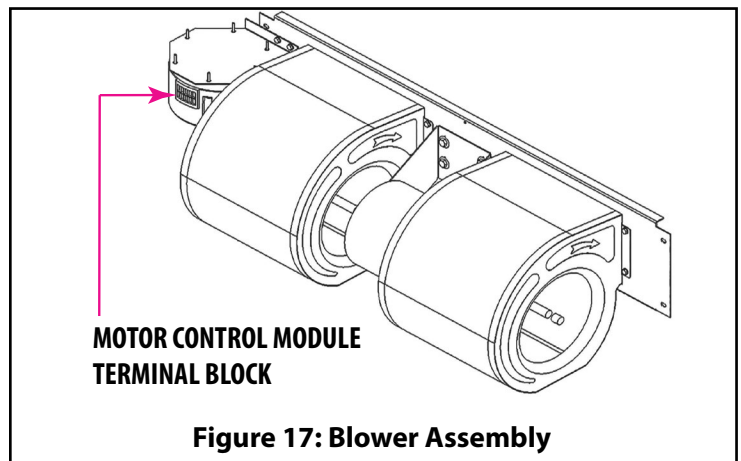

Figure 17: Blower Assembly

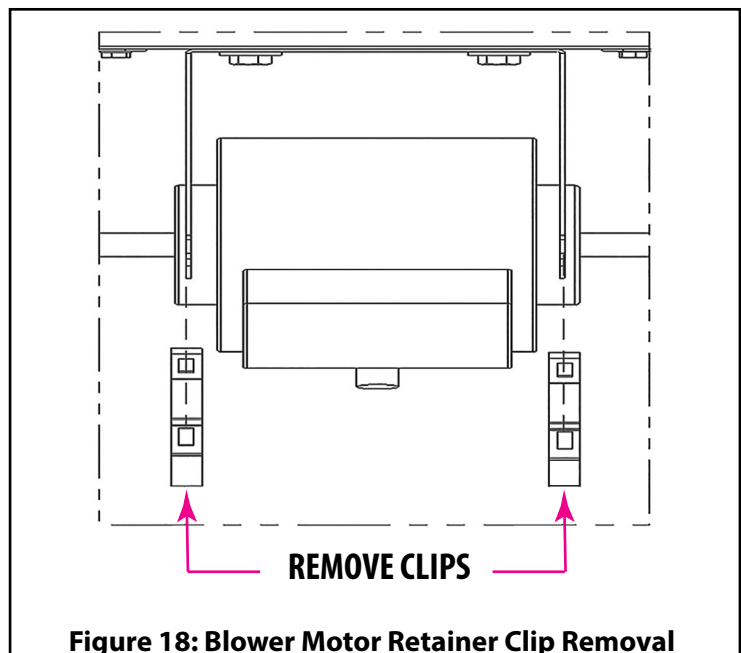

Figure 18: Blower Motor Retainer Clip Removal

TXV TROUBLESHOOTING

The thermostatic expansion valve (TXV) is like the carburetor in a car engine. It opens and closes to allow the correct amount of refrigerant flow through the system. When the TXV isn't working properly, the capacity and efficiency of the system is reduced. If a faulty TXV is suspected, perform the following tests:

1. Connect refrigerant gauges to the system and check that the thermostatic expansion valve (TXV) is like the carburetor in a car engine. It opens and closes to allow the correct amount of refrigerant flow through the system. When the TXV isn't working properly, the capacity and efficiency of the system is reduced. If a faulty TXV is suspected, perform the following tests:
2. Connect refrigerant gauges to the system and check that the refrigerant pressures, liquid subcooling and suction superheat levels are correct according to the outdoor unit charging chart. Subcooling at the outdoor unit liquid service valve is normally around 10°F and superheat at the outdoor unit suction service valve is normally between 8-12°F, but these can vary depending on the manufacturer and model of the outdoor unit.
3. Check to see if the indoor airflow through the system is correct. Check to see if the indoor and outdoor coils and indoor air filters are dirty. Clean dirty coils and clean/replace dirty air- filters as necessary before measuring air-flow and checking pressures, superheat, and subcooling.
4. Make sure the refrigerant charge in the system is correct. This step may require weighing the refrigerant in the system. Once refrigerant charge weight has been adjusted as necessary, recheck the refrigerant pressures, subcooling and superheat. If the pressures, subcooling and superheat are still not correct, the TXV may be defective or the TXV inlet strainer or the liquid line filter drier is plugged with debris.
5. A good way to determine if the TXV is defective is to remove the TXV's sensing bulb from the suction line and check the pressures, subcooling, superheat again. No change in the pressures, subcooling, and superheat levels is an indication the TXV is defective. Another test that can be performed is to place the sensing bulb in ice water and recheck the pressures, superheat, and subcooling levels. If these values do not change, the TXV is likely defective.

Additional TXV Troubleshooting Information Low Suction Pressure – High Superheat

POSSIBLE CAUSES:

1. Undersized TXV
2. TXV superheat adjustment too high
3. High indoor coil pressure drop due to internal restriction
4. TXV sensing bulb installed on bottom of suction line
5. Restricted or capped TXV external equalizer tube
6. Improper TXV external equalizer location (must be located on the suction manifold after the last feeder tube)
7. Low refrigerant charge
8. Plugged liquid line filter drier
9. Plugged TXV inlet strainer
10. Low outdoor ambient temperature

High Suction Pressure – Low Superheat

POSSIBLE CAUSES:

1. Oversized TXV
2. TXV seat leakage
3. TXV superheat adjustment too low
4. Improper TXV sensing bulb installation
 - a) Poor thermal contact with suction line (loose clamp)

- b) Uninsulated sensing bulb
- c) Warm location
1. Bad compressor (low capacity)
2. Incorrectly located external equalizer line (must be located on the suction manifold after the last feeder tube)

Low Suction Pressure – Low Superheat

POSSIBLE CAUSES:

1. Low system load:
 - a) Insufficient indoor airflow
 - b) Dirty indoor air filters
 - c) Return air too cold
 - d) Indoor coil icing or frosting
2. Poor air distribution over indoor coil
3. Improper indoor/outdoor coil internal volume balance (indoor coil too big or too small causing incorrect refrigerant charge balance between cooling and heating modes)
4. Oil trapped in indoor coil

Things to Check Before Replacing TXV

1. Slowly loosen the flare nut on the TXV external equalizer connected to the suction line port with a flare nut. If there is a large pressure release when the nut has been loosened, tighten the nut. If this results in a slight pressure release or no pressure release; the Schrader valve stem is not being depressed. Install an anti-blow back fitting to the external equalizer line of the TXV to depress the Schrader valve stem and check for proper operation of the TXV.
2. Remove the sensing bulb from the suction line and hold in a warm hand. The high side pressure should drop and low side pressure should increase as the TXV opens. Place the sensing bulb in ice water. The high side pressure should increase and the low side pressure should decrease as the TXV closes. If the pressures do not change when these tests are conducted, the TXV is faulty.

SECTION 6: BLOWER PERFORMANCE

Model No.	Nominal Cooling Tons	Blower Motor		Motor Code	Blower Wheel Size	Motor Speed Tap	CFM@ 0.10" W.C.	CFM@ 0.20" W.C.	CFM@ 0.30" W.C.	CFM@ 0.40" W.C.	CFM@ 0.50" W.C.
		HP	Volts								
HE*1**-*-A Electric Heat HE*3**-*-D Electric Heat	1.5 - 2.0	0.33	240	*J	(2) 7 x 8	1	541	482	416	357	315
						2	646	598	541	482	438
						3	735	694	659	597	549
						4	840	804	770	735	672
						5	888	851	819	785	739
HE*1**-*-B Electric Heat HE*3**-*-D Electric Heat	1.5 - 2.5	0.33	240	*K	(2) 7 x 9	1	570	480	398	327	257
						2	669	588	512	450	387
						3	761	691	618	557	499
						4	865	797	730	667	609
						5	915	851	782	724	657
HE*1**-*-B Electric Heat HE*3**-*-D Electric Heat	1.5 - 2.5	0.5	240	*M	(2) 7 x 9	1	906	837	762	701	627
						2	1019	955	887	822	768
						3	1101	1043	987	922	846
						4	1202	1151	1098	1041	981
						5	1312	1258	1209	1151	1105
HE*1**-*-C Electric Heat HE*3**-*-D Electric Heat	1.5 - 3.0	0.5	240	*M	(2) 7 x 9	1	928	836	750	689	617
						2	1024	948	866	798	739
						3	1131	1062	989	917	846
						4	1225	1160	1091	1026	957
						5	1327	1267	1211	1138	1075
HE*1**-*-D Electric Heat HE*3**-*-D Electric Heat	1.5 - 3.0	0.5	240	*M	(2) 7 x 9	1	987	922	849	769	696
						2	1073	1008	945	880	817
						3	1191	1127	1071	1006	949
						4	1285	1241	1186	1127	1047
						5	1400	1332	1290	1246	1191

Table 5: HEC1/HEU1/HEC3/HEU3 Blower Performance – CFM - Without Air Filters

Minimum CFM for Electric Heat: 3kW = 195 CFM; 5kW = 325 CFM; 6 kW = 390 CFM; 8kW = 520 CFM; 10kW = 650 CFM

Model No.	Nominal Cooling Tons	Bower Motor		Code	Blower Wheel	Motor Speed	AMPS@ 0.10" W.C.	AMPS@ 0.20" W.C.	AMPS@ 0.30" W.C.	AMPS@ 0.40" W.C.	AMPS@ 0.50" W.C.
		HP	Volts								
HE*1**-*-A Electric Heat HE*3**-*-A Electric Heat	1.5 - 2.0	0.33	240	*J	(2) 7 x 8	1	0.28	0.30	0.33	0.36	0.38
						2	0.36	0.39	0.43	0.45	0.48
						3	0.47	0.50	0.53	0.56	0.59
						4	0.62	0.64	0.67	0.70	0.74
						5	0.69	0.72	0.75	0.78	0.81
HE*1**-*-A Electric Heat HE*3**-*-A Electric Heat	1.5 - 2.5	0.33	240	*K	(2) 7 x 9	1	0.27	0.30	0.33	0.35	0.37
						2	0.35	0.38	0.41	0.44	0.47
						3	0.44	0.47	0.50	0.53	0.56
						4	0.55	0.59	0.62	0.66	0.69
						5	0.62	0.65	0.68	0.72	0.75
HE*1**-*-A Electric Heat HE*3**-*-A Electric Heat	1.5 - 2.5	0.5	240	*M	(2) 7 x 9	1	0.61	0.65	0.66	0.68	0.71
						2	0.74	0.78	0.81	0.83	0.86
						3	0.87	0.92	0.95	0.97	0.99
						4	1.08	1.11	1.13	1.16	1.20
						5	1.33	1.36	1.41	1.43	1.46
HE*1**-*-A Electric Heat HE*3**-*-A Electric Heat	1.5 - 3.0	0.5	240	*M	(2) 7 x 9	1	0.51	0.54	0.57	0.61	0.64
						2	0.62	0.66	0.70	0.72	0.76
						3	0.75	0.78	0.82	0.85	0.88
						4	0.88	0.92	0.96	0.98	1.04
						5	1.08	1.12	1.13	1.16	1.21
HE*1**-*-A Electric Heat HE*3**-*-A Electric Heat	1.5 - 3.0	0.5	240	*M	(2) 7 x 9	1	0.75	0.78	0.81	0.85	0.88
						2	0.90	0.94	0.95	1.00	1.03
						3	1.10	1.13	1.16	1.16	1.20
						4	1.35	1.38	1.42	1.46	1.50
						5	1.66	1.70	1.73	1.77	1.80

Table 6: HEC1/HEU1/HEC3/HEU3 Blower Performance – Motor Amps - Without Air Filters

Model No.	Nominal Cooling Tons	Bower Motor		Motor Code	Blower Wheel Size	Motor Speed Tap	CFM@ 0.10" W.C.	CFM@ 0.20" W.C.	CFM@ 0.30" W.C.	CFM@ 0.40" W.C.	CFM@ 0.50" W.C.
		HP	Volts								
HE*2**.*-A Hydronic Heat HE*4**.*-A Hydronic Heat	1.5 - 2.0	0.33	115	*N	(2) 7 x 8	1	533	485	439	397	350
						2	629	589	546	508	457
						3	728	694	658	625	579
						4	832	801	761	727	680
						5	886	857	818	786	740
HE*2**.*-B Hydronic Heat HE*4**.*-B Hydronic Heat	1.5 - 2.5	0.33	115	*O	(2) 7 x 9	1	556	486	426	363	291
						2	646	593	541	476	423
						3	749	699	651	598	555
						4	844	798	749	704	657
						5	897	854	809	764	721
HE*2**.*-B Hydronic Heat HE*4**.*-B Hydronic Heat	1.5 - 2.5	0.50	115	*R	(2) 7 x 9	1	883	834	787	737	700
						2	978	926	885	834	791
						3	1075	1033	991	946	905
						4	1192	1149	1105	1071	1029
						5	1302	1253	1213	1176	1138
HE*2**.*-C Hydronic Heat HE*4**.*-C Hydronic Heat	1.5 - 3.0	0.50	115	*R	(2) 7 x 9	1	903	845	791	732	665
						2	1016	958	903	853	789
						3	1118	1065	1010	958	912
						4	1232	1179	1135	1089	1047
						5	1310	1261	1221	1180	1137
HE*2**.*-D Hydronic Heat HE*4**.*-D Hydronic Heat	1.5 - 3.0	0.50	115	*R	(2) 7 x 9	1	901	837	781	716	658
						2	992	939	876	823	753
						3	1090	1043	987	934	878
						4	1200	1152	1107	1061	1012
						5	1297	1252	1205	1161	1111

Table 7: HEC2/HEU2/HEC4/HEU4 Blower Performance – CFM – Without Air Filters

Model No.	Nominal Tons	Motor HP	Volts 1 Ph. 50/60	Motor Code	Blower Wheel	Motor Tap	AMPS @ 0.10" W.C.	AMPS @ 0.20" W.C.	AMPS @ 0.30" W.C.	AMPS @ 0.40" W.C.	AMPS @ 0.50" W.C.	
HE*2**-*-A Hydronic	1.5 - 2.0	0.33	115	*N	(2) 7 X 8	1	0.52	0.56	0.61	0.65	0.70	
						2	0.75	0.79	0.84	0.88	0.92	
						HE*4**-*-A Hydronic	3	1.02	1.06	1.08	1.14	1.21
						4	1.30	1.36	1.42	1.46	1.50	
						5	1.53	1.56	1.63	1.66	1.71	
HE*2**-*-B Hydronic	1.5 - 2.5	0.33	115	*O	(2) 7 X 9	1	0.54	0.58	0.63	0.68	0.74	
						2	0.71	0.76	0.81	0.88	0.94	
						HE*4**-*-B Hydronic	3	1.01	1.04	1.08	1.14	1.22
						4	1.32	1.37	1.45	1.49	1.54	
						5	1.57	1.63	1.67	1.72	1.78	
HE*2**-*-B Hydronic	1.5 - 2.5	0.50	115	*R	(2) 7 X 9	1	1.39	1.44	1.51	1.53	1.55	
						2	1.72	1.76	1.82	1.88	1.93	
						HE*4**-*-B Hydronic	3	2.20	2.25	2.29	2.32	2.41
						4	2.77	2.90	2.94	3.04	3.02	
						5	3.54	3.53	3.64	3.68	3.65	
HE*2**-*-C Hydronic	1.5 - 3.0	0.50	115	*R	(2) 7 X 9	1	1.20	1.25	1.31	1.36	1.41	
						2	1.59	1.62	1.68	1.71	1.76	
						HE*4**-*-C Hydronic	3	1.93	1.99	2.06	2.08	2.15
						4	2.52	2.57	2.61	2.66	2.74	
						5	3.15	3.19	3.25	3.29	3.35	
HE*2**-*-D Hydronic	1.5 - 3.0	0.50	115	*R	(2) 7 X 9	1	1.21	1.29	1.32	1.38	1.44	
						2	1.47	1.53	1.63	1.66	1.68	
						HE*4**-*-D Hydronic	3	1.89	1.93	2.01	2.04	2.08
						4	2.40	2.45	2.52	2.54	2.60	
						5	2.86	2.96	3.02	3.04	3.10	

Table 8: HEC2/HEU2/HEC4/HEU4 Blower Performance – Motor Amps - Without Air Filters

SECTION 7: SPECIAL PIPING INSTRUCTIONS FOR A2L CLASS FLAMMABLE REFRIGERANTS

WARNING

RISK OF FIRE

This unit is equipped with a refrigerant leak detection system for safety and with electrically powered safety measures. To be effective, the unit must be electrically powered at all times after installation, other than when servicing.

Piping material, pipe routing, and installation shall, including protection from physical damage in operation and service, be in compliance with national and local codes and standards, such as ASHRAE 15, IAPMO Uniform Mechanical Code, ICC International Mechanical Code, or CSA B52 shall be observed. All field joints shall be accessible for inspection prior to being covered or enclosed.

Mechanical refrigerant connections must be made in accordance with the following procedure and shall be accessible for maintenance purposes.

The installation of pipe-work shall be kept to a minimum.

Due to this air-handler being used with an A2L class flammable refrigerant, the refrigerant pipe-work shall not be installed in an unventilated space, if that space is smaller than the minimum floor area shown in Tables 30 and 31 in the Installation Instructions Manual for this air handler unless there are no joints in the pipe-work in that space (e.g.: pipework that is run in walls or between floors).

Since refrigerant line length affects the final refrigerant charge, the final refrigerant charge after field charging of the system must be noted and used when determining the minimum floor area of the conditioned space from Tables 30 and 31 in the Installation Instructions Manual for this air handler.

Refrigerant Connections

For appliances using flammable refrigerants, all joints made in the installation between parts of the refrigerating system, with at least one part charged, shall be made in accordance with the following:

- A brazed, welded, or mechanical connection shall be made before opening the valves to permit refrigerant to flow between the refrigerating system parts. A vacuum valve shall be provided to evacuate the interconnecting pipe or any uncharged refrigerating system part.
- Mechanical connectors used indoors shall comply with ISO 14903 or UL 207 Annex A (USA only). When mechanical connectors are reused indoors, sealing parts shall be renewed. When flared joints are reused indoors, the flare part shall be refabricated.
- Refrigerant tubing shall be protected or enclosed to avoid damage.
- Flexible refrigerant connectors (such as connecting lines between the indoor and outdoor unit) that may be displaced during normal operation shall be protected against mechanical damage.
- For installations with field applied joints that are exposed in the occupied space, these joints shall be at least one of the following:
 - mechanical joints in compliance with ISO 14903 or UL 207 Annex A (USA only)
 - welded or brazed joints; or

- joints in enclosures that vent to the unit or to the outside.

Provision shall be made for expansion and contraction of long runs of piping.

Protection devices, piping, and fittings shall be protected as far as possible against adverse environmental effects, for example, the danger of water collecting and freezing in relief pipes or the accumulation of dirt and debris.

Piping in refrigeration systems shall be so designed and installed to minimize the likelihood of hydraulic shock damaging the system. After completion of field piping for split systems, the field pipework shall be pressure tested with an inert gas and then vacuum tested prior to refrigerant charging, according to the following requirements:

- The minimum test pressure for the low side of the system shall be the low side design pressure and the minimum test pressure for the high side of the system shall be the high side design pressure, unless the high side of the system cannot be isolated from the low side of the system in which case the entire system shall be pressure tested to the low side design pressure.
- The test pressure after removal of pressure source shall be maintained for at least 1 hour with no decrease of pressure indicated by the test gauge, with test gauge resolution not During the evacuation test, after achieving a vacuum level specified in the manual or less, the refrigeration system shall be isolated from the vacuum pump and the pressure shall not rise above 1500 microns within 10 min. The vacuum pressure level shall be the lesser of 500 microns or the value required for compliance with national and local codes and standards, which may vary between residential, commercial, and industrial buildings.

Field made refrigerant joints indoors shall also be tightness tested after the system is charged with refrigerant. The test method shall have a sensitivity of 5 grams per year of refrigerant or better under a pressure of at least 0.25 times the maximum allowable pressure. No leak shall be detected.

SECTION 8: REFRIGERANT LEAK DETECTION SYSTEM OPERATION AND SENSOR REPLACEMENT

WARNING

This air handler is equipped with a refrigerant leak mitigation system that energizes the air handler blower motor to deliver at least the required minimum airflow (See Table 30 and 31 in the Installation Instructions for this air handler) when the refrigerant leak detection system detects a leak. This will dilute the flammable A2L class refrigerant to a point that it no longer poses a risk of an explosion or fire. Follow the procedure “Verifying Proper Functioning of Refrigerant Leak Mitigation System” later in this section to confirm the refrigerant mitigation system is functioning as it should.

This air handler is equipped with a refrigerant leak detection system consisting of a leak mitigation refrigerant sensor with integral relays. Should a refrigerant leak occur in the indoor coil, the refrigerant leak detection system will energize the indoor blower on the cooling mode speed tap and will open the 24VAC circuit to the outdoor unit compressor contactor. The circulation of air will disperse the leaked flammable refrigerant into the conditioned space where it will be diluted to point where it can no longer be ignited by an ignition source. This process is referred to as "Leak Mitigation". The indoor blower will continue to operate until 5 minutes after the concentration of the refrigerant at the sensor drops below the sensor's setpoint. Should the concentration of the refrigerant rise above the setpoint of the sensor, the mitigation cycle will repeat until the refrigerant concentration stays below the setpoint of the sensor. The sensor pigtail marked "ALARM" will normally be energized with 24VAC when no leak is detected and will be de-energized when a leak is detected for the purpose of notifying a building management system to issue a refrigerant leak alarm.

Should the sensor fail or if the wiring to the sensor is damaged or disconnected, the sensor will automatically enter the mitigation mode until the sensor is replaced or the wiring is reconnected or repaired.

IMPORTANT NOTE: The outdoor unit control wiring must be connected to the refrigerant sensor "Y-CC" pigtail and the "COM" on the air handler low voltage terminal strip for the refrigerant detection system to de-energize the compressor during the leak mitigation mode of operation.

Verifying Proper Functioning of Refrigerant Leak Mitigation System

A test to confirm the proper functioning of the refrigerant leak mitigation system must be performed at the final system check-out. Follow the procedure below to perform that test.

1. Open the ceiling access panel below the air handler.
2. Locate the black refrigerant sensor located under the blower motor (See Figure 11).

Leak Detected During Cooling Cycle

3. Set the thermostat to "COOL" and the fan switch to "AUTO" and lower the temperature setpoint below the indoor temperature so the system enters the cooling mode.
4. Confirm the outdoor unit compressor is operating.
5. Within 30 seconds of the compressor starting, release a small amount of refrigerant on the refrigerant sensor to activate the leak mitigation mode.
6. Confirm the outdoor unit compressor and fan motor shut down and the indoor blower continues to operate.
7. Confirm the indoor blower is energized and 24V is not present at the air handler pigtail marked "ALARM".
8. Confirm the outdoor unit compressor and fan motor are re-energized approximately 5 minutes after the flow of refrigerant near the sensor has ended and that the indoor blower continues to operate.

Leak Detected During the OFF Cycle

9. Set the thermostat to the "OFF" position and wait until the outdoor unit compressor and fan motor stop and indoor blower stops.
10. Release a small amount of refrigerant on the refrigerant sensor to activate the leak mitigation mode

11. Confirm the indoor blower is energized and 24V is not present at the air handler pigtail marked "ALARM".
12. Confirm the indoor blower shuts down after approximately 5 minutes after the flow of refrigerant on the refrigerant sensor has ended.
13. If the Refrigerant Leak Mitigation System does not operate as stated above, check for loose wiring connections or replace the refrigerant sensor.
14. Close the ceiling access panel and secure it with the thumb screws.
15. Set the thermostat to the desired operating mode and temperature.

If the leak detection system does not function properly when subjected to the above procedure, check for miswiring of the system. If the wiring connections are found to be correct per the air handler wiring diagram, replace the sensor with an approved replacement from the manufacturer.

The replacement sensor part numbers are as follows:

R-32 Refrigerant: R68ALL001

R-454B Refrigerant: R68ALL002

R-32/R-454B Refrigerant (Dual Refrigerant): R68ALL003

Servicing the Leak Detection System/Sensor Replacement

When the refrigerant leak detection system sensor fails or reaches the end of its life, the leak detection system will enter and remain in the leak mitigation mode even though there is no refrigerant leak present. If the leak detection system continues to operate in the mitigation mode even when a refrigerant leak isn't indicated by a portable refrigerant leak detector, replace the sensor with an approved replacement from the air handler manufacturer using the following procedure.

Refrigerant Sensor Replacement Procedure

The refrigerant sensor is located below the blower motor. See Figure 11 for the location of the sensor. Disconnect the wiring harness connector from the failed sensor and remove the sensor mounting screws. Discard the failed sensor. Mount the replacement sensor in the same location as the failed sensor that was removed and connect the sensor wiring harness connector to the sensor. Verify the proper function of the refrigerant leak mitigation system using the procedure described earlier.

IMPORTANT: The sensor wiring harness plug must be pointing down or horizontal. If the plug is pointing up, water could collect in the plug and result in operational issues.

IMPORTANT: Mortex may source sensors from various manufacturers that have a different wiring harness connection. A wiring adapter may be necessary to allow the replacement sensor to connect the sensor wiring harness. The wiring adapter will be provided with the replacement sensor. Alternate mounting holes are provided to accommodate the various approved sensors. Only use a replacement sensor approved by and provided by Mortex to assure proper operating and compatibility.

SECTION 9: ACCESSORIES

Part Number	Description
HCPL-1	HEC/HEU-LOUVERED - 27.5" x 43"
HCPL-2	HEC/HEU-LOUVERED - 27.5" x 49"
HCPL-3	HEC/HEU-LOUVERED - 27.5" x 55.5"
HCPL-4	HEC/HEU-LOUVERED - 27.5" x 62.5"
CPNL-1	HEC/HEU-NON-LOUVERED - 27.5" x 43"
CPNL-2	HEC/HEU-NON-LOUVERED - 27.5" x 49"
CPNL-3	HEC/HEU-NON-LOUVERED - 27.5" x 55.5"
CPNL-4	HEC/HEU-NON-LOUVERED - 27.5" x 62.5"

Table 9: Accessory List Without Air Filters

SECTION 10: REPLACEMENT PARTS

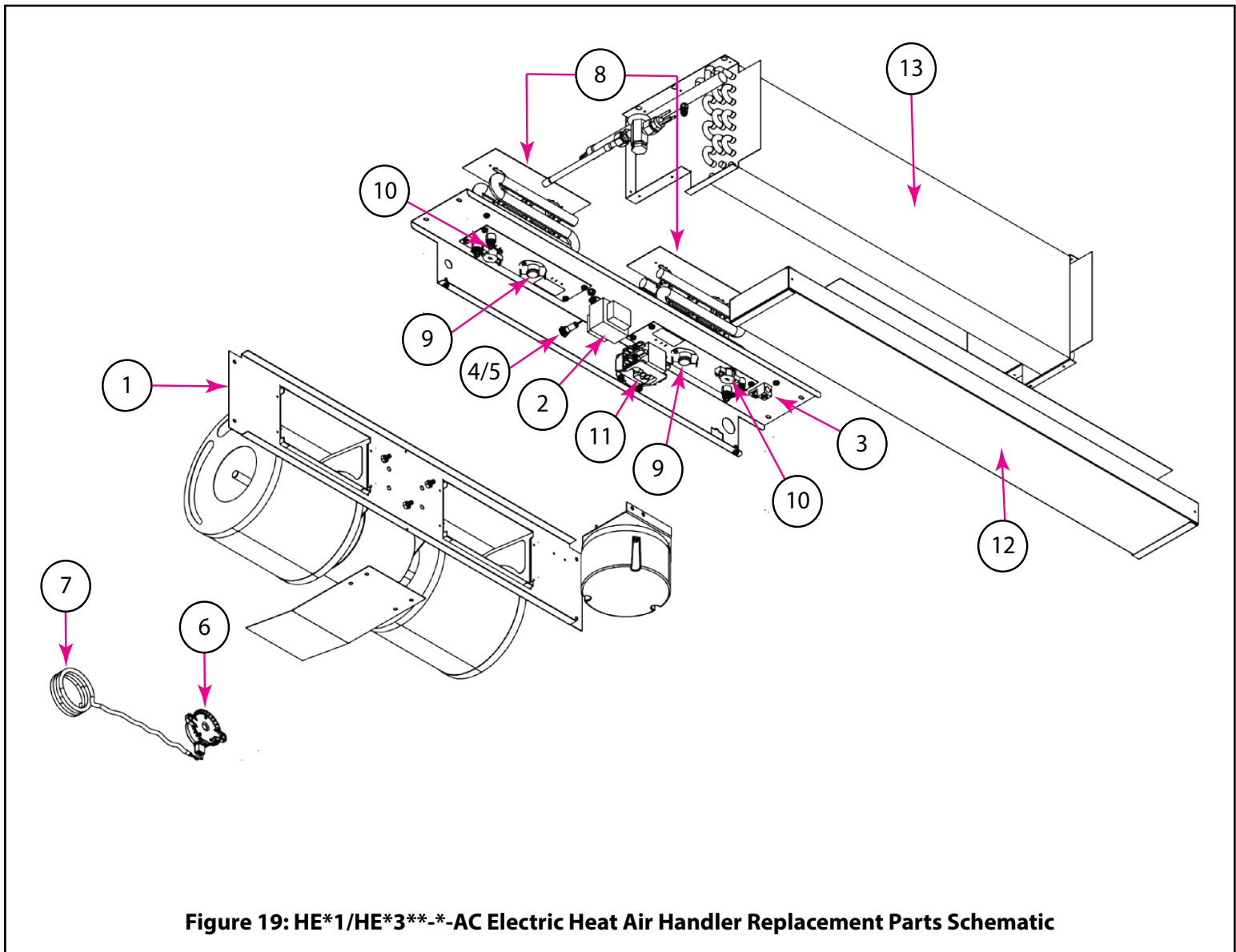

Figure 19: HE*1/HE*3-*-AC Electric Heat Air Handler Replacement Parts Schematic**

HE*1/HE*3**-*-AC ELECTRIC HEAT MODELS			
Item #	Qty.	Part #	Description
1	1		Blower Assembly - Contact factory rep to obtain the correct blower assembly.
2	1	R68AA0003	208/240-24V Transformer
3	1	R68DC0001	Ground Lug
4	1	R73MH0001	3 Amp Fuse
5	1	R73MHA001	Fuse Holder
6	1	R68ALL001	R-32 Refrigerant Leak Sensor
6	1	R68ALL002	R-454B Refrigerant Leak Sensor
6	1	R68ALL003	R-32/R-454B Refrigerant (Dual Refrigerant)
7	1	R73BB0053	Refrigerant Leak Sensor Wire Harness
3 KW Electric Heat			
8	1	R86CJ1076	3 kW Element (Kit - 2 EA. 1.5 kW Heater Elements with Limits)
9	2	R68CA0001	Auto-Reset 140°F Limit Switch (Opens at 140°F - Closes at 110°F)
10	2	R68CA0012	Non-Resettable Limit Switch (Opens 180°F)
11	1	R68AB0019	Double Pole Electric Heat Contactor - 50 Amp Resistive
5 KW Electric Heat			
8	1	R86CJ1077	5 kW Element (Kit - 2 EA. 2.5 kW Heater Elements with Limits)
9	2	R68CA0001	Auto-Reset 140°F Limit Switch (Opens at 140°F - Closes at 110°F)
10	2	R68CA0012	Non-Resettable Limit Switch (Opens 180°F)
11	1	R68AB0019	Double Pole Electric Heat Contactor - 50 Amp Resistive
6 KW Electric Heat			
8	1	R86CJ1078	6 kW Element (Kit - 2 EA. 3.0 kW Heater Elements with Limits)
9	2	R68CA0001	Auto-Reset 140°F Limit Switch (Opens at 140°F - Closes at 110°F)
10	2	R68CA0012	Non-Resettable Limit Switch (Opens 180°F)
11	1	R68AB0019	Double Pole Electric Heat Contactor - 50 Amp Resistive
8 KW Electric Heat			
8	1	R86CJ1079	8 kW Element (Kit - 2 EA. 4.0 kW Heater Elements with Limits)
9	2	R68CA0001	Auto-Reset 140°F Limit Switch (Opens at 140°F - Closes at 110°F)
10	2	R68CA0012	Non-Resettable Limit Switch (Opens 180°F)
11	1	R68AB0019	Double Pole Electric Heat Contactor - 50 Amp Resistive
10 KW Electric Heat			
8	1	R86CJ1080	10 kW Element (Kit - 2 EA. 5.0 kW Heater Elements with Limits)
9	2	R68CA0001	Auto-Reset 140°F Limit Switch (Opens at 140°F - Closes at 110°F)
10	2	R68CA0012	Non-Resettable Limit Switch (Opens 180°F)
11	1	R68AB0019	Double Pole Electric Heat Contactor - 50 Amp Resistive
DRAIN PAN			
12	1	R86FDA001	Galvanized G90 Drain Pan With Coating for F.D. 30
DX COIL			
13	1	R86BB0072C	3 Row, 10" x 30", A-Coil, 5/16"
CHILLED WATER COILS			
13			CHILLED WATER COILS - There are too many chilled water coil models to list. Contact factory sales rep to obtain the correct coil.

Table 10: HE*1/HE*3-*-AC Electric Heat Air Handler Replacement Parts List**

HE*1/HE*3**-*-BC ELECTRIC HEAT MODELS			
Item #	Qty.	Part #	Description
1	1		Blower Assembly - Contact factory rep to obtain the correct blower assembly.
2	1	R68AA0003	208/240-24V Transformer
3	1	R68DC0001	Ground Lug
4	1	R73MH0001	3 Amp Fuse
5	1	R73MHA001	Fuse Holder
6	1	R68ALL001	R-32 Refrigerant Leak Sensor
6	1	R68ALL002	R-454B Refrigerant Leak Sensor
6	1	R68ALL003	R-32/R-454B Refrigerant (Dual Refrigerant)
7	1	R73BB0053	Refrigerant Leak Sensor Wire Harness
3 KW Electric Heat			
8	1	R86CJ1076	3 kW Element (Kit - 2 EA. 1.5 kW Heater Elements with Limits)
9	2	R68CA0001	Auto-Reset 140°F Limit Switch (Opens at 140°F - Closes at 110°F)
10	2	R68CA0012	Non-Resettable Limit Switch (Opens 180°F)
11	1	R68AB0019	Double Pole Electric Heat Contactor - 50 Amp Resistive
5 KW Electric Heat			
8	1	R86CJ1077	5 kW Element (Kit - 2 EA. 2.5 kW Heater Elements with Limits)
9	2	R68CA0001	Auto-Reset 140°F Limit Switch (Opens at 140°F - Closes at 110°F)
10	2	R68CA0012	Non-Resettable Limit Switch (Opens 180°F)
11	1	R68AB0019	Double Pole Electric Heat Contactor - 50 Amp Resistive
6 KW Electric Heat			
8	1	R86CJ1078	6 kW Element (Kit - 2 EA. 3.0 kW Heater Elements with Limits)
9	2	R68CA0001	Auto-Reset 140°F Limit Switch (Opens at 140°F - Closes at 110°F)
10	2	R68CA0012	Non-Resettable Limit Switch (Opens 180°F)
11	1	R68AB0019	Double Pole Electric Heat Contactor - 50 Amp Resistive
8 KW Electric Heat			
8	1	R86CJ1079	8 kW Element (Kit - 2 EA. 4.0 kW Heater Elements with Limits)
9	2	R68CA0001	Auto-Reset 140°F Limit Switch (Opens at 140°F - Closes at 110°F)
10	2	R68CA0012	Non-Resettable Limit Switch (Opens 180°F)
11	1	R68AB0019	Double Pole Electric Heat Contactor - 50 Amp Resistive
10 KW Electric Heat			
8	1	R86CJ1080	10 kW Element (Kit - 2 EA. 5.0 kW Heater Elements with Limits)
9	2	R68CA0001	Auto-Reset 140°F Limit Switch (Opens at 140°F - Closes at 110°F)
10	2	R68CA0012	Non-Resettable Limit Switch (Opens 180°F)
11	1	R68AB0019	Double Pole Electric Heat Contactor - 50 Amp Resistive
DRAIN PAN			
12	1	R86FDA001	Galvanized G90 Drain Pan With Coating for F.D. 30
DX COIL			
13	1	R86BB0072C	3 Row, 10" x 30", A-Coil, 5/16"
CHILLED WATER COILS			
13	CHILLED WATER COILS - There are too many chilled water coil models to list. Contact factory sales rep to obtain the correct coil.		

Table 11. HE*1/HE*3-*-BC Electric Heat Air Handler Replacement Parts List**

HE*1/HE*3**-*-CC ELECTRIC HEAT MODELS			
Item #	Qty.	Part #	Description
1	1		Blower Assembly - Contact factory rep to obtain the correct blower assembly.
2	1	R68AA0003	208/240-24V Transformer
3	1	R68DC0001	Ground Lug
4	1	R73MH0001	3 Amp Fuse
5	1	R73MHA001	Fuse Holder
6	1	R68ALL001	R-32 Refrigerant Leak Sensor
6	1	R68ALL002	R-454B Refrigerant Leak Sensor
6	1	R68ALL003	R-32/R-454B Refrigerant (Dual Refrigerant)
7	1	R73BB0053	Refrigerant Leak Sensor Wire Harness
3 KW Electric Heat			
8	1	R86CJ1076	3 kW Element (Kit - 2 EA. 1.5 kW Heater Elements with Limits)
9	2	R68CA0001	Auto-Reset 140°F Limit Switch (Opens at 140°F - Closes at 110°F)
10	2	R68CA0012	Non-Resettable Limit Switch (Opens 180°F)
11	1	R68AB0019	Double Pole Electric Heat Contactor - 50 Amp Resistive
5 KW Electric Heat			
8	1	R86CJ1077	5 kW Element (Kit - 2 EA. 2.5 kW Heater Elements with Limits)
9	2	R68CA0001	Auto-Reset 140°F Limit Switch (Opens at 140°F - Closes at 110°F)
10	2	R68CA0012	Non-Resettable Limit Switch (Opens 180°F)
11	1	R68AB0019	Double Pole Electric Heat Contactor - 50 Amp Resistive
6 KW Electric Heat			
8	1	R86CJ1078	6 kW Element (Kit - 2 EA. 3.0 kW Heater Elements with Limits)
9	2	R68CA0001	Auto-Reset 140°F Limit Switch (Opens at 140°F - Closes at 110°F)
10	2	R68CA0012	Non-Resettable Limit Switch (Opens 180°F)
11	1	R68AB0019	Double Pole Electric Heat Contactor - 50 Amp Resistive
8 KW Electric Heat			
8	1	R86CJ1079	8 kW Element (Kit - 2 EA. 4.0 kW Heater Elements with Limits)
9	2	R68CA0001	Auto-Reset 140°F Limit Switch (Opens at 140°F - Closes at 110°F)
10	2	R68CA0012	Non-Resettable Limit Switch (Opens 180°F)
11	1	R68AB0019	Double Pole Electric Heat Contactor - 50 Amp Resistive
10 KW Electric Heat			
8	1	R86CJ1080	10 kW Element (Kit - 2 EA. 5.0 kW Heater Elements with Limits)
9	2	R68CA0001	Auto-Reset 140°F Limit Switch (Opens at 140°F - Closes at 110°F)
10	2	R68CA0012	Non-Resettable Limit Switch (Opens 180°F)
11	1	R68AB0019	Double Pole Electric Heat Contactor - 50 Amp Resistive
DRAIN PAN			
12	1	R86FDA003	Galvanized G90 Drain Pan With Coating for F.D. 38
DX COIL			
13	1	R86BB0074C	3-Row, 10" x 38", A-Coil, 5/16"
CHILLED WATER COILS			
13	CHILLED WATER COILS - There are too many chilled water coil models to list. Contact factory sales rep to obtain the correct coil.		

Table 12: HE*1/HE*3-*-CC Electric Heat Air Handler Replacement Parts List**

HE*1/HE*3**-*-DC ELECTRIC HEAT MODELS			
Item #	Qty.	Part #	Description
1	1		Blower Assembly - Contact factory rep to obtain the correct blower assembly.
2	1	R68AA0003	208/240-24V Transformer
3	1	R68DC0001	Ground Lug
4	1	R73MH0001	3 Amp Fuse
5	1	R73MHA001	Fuse Holder
6	1	R68ALL001	R-32 Refrigerant Leak Sensor
6	1	R68ALL002	R-454B Refrigerant Leak Sensor
6	1	R68ALL003	R-32/R-454B Refrigerant (Dual Refrigerant)
7	1	R73BB0053	Refrigerant Leak Sensor Wire Harness
3 KW Electric Heat			
8	1	R86CJ1076	3 kW Element (Kit - 2 EA. 1.5 kW Heater Elements with Limits)
9	2	R68CA0001	Auto-Reset 140°F Limit Switch (Opens at 140°F - Closes at 110°F)
10	2	R68CA0012	Non-Resettable Limit Switch (Opens 180°F)
11	1	R68AB0019	Double Pole Electric Heat Contactor - 50 Amp Resistive
5 KW Electric Heat			
8	1	R86CJ1077	5 kW Element (Kit - 2 EA. 2.5 kW Heater Elements with Limits)
9	2	R68CA0001	Auto-Reset 140°F Limit Switch (Opens at 140°F - Closes at 110°F)
10	2	R68CA0012	Non-Resettable Limit Switch (Opens 180°F)
11	1	R68AB0019	Double Pole Electric Heat Contactor - 50 Amp Resistive
6 KW Electric Heat			
8	1	R86CJ1078	6 kW Element (Kit - 2 EA. 3.0 kW Heater Elements with Limits)
9	2	R68CA0001	Auto-Reset 140°F Limit Switch (Opens at 140°F - Closes at 110°F)
10	2	R68CA0012	Non-Resettable Limit Switch (Opens ??? °F)
11	1	R68AB0019	Double Pole Electric Heat Contactor - 50 Amp Resistive
8 KW Electric Heat			
8	1	R86CJ1079	8 kW Element (Kit - 2 EA. 4.0 kW Heater Elements with Limits)
9	2	R68CA0001	Auto-Reset 140°F Limit Switch (Opens at 140°F - Closes at 110°F)
10	2	R68CA0012	Non-Resettable Limit Switch (Opens 180°F)
11	1	R68AB0019	Double Pole Electric Heat Contactor - 50 Amp Resistive
10 KW Electric Heat			
8	1	R86CJ1080	10 kW Element (Kit - 2 EA. 5.0 kW Heater Elements with Limits)
9	2	R68CA0001	Auto-Reset 140°F Limit Switch (Opens at 140°F - Closes at 110°F)
10	2	R68CA0012	Non-Resettable Limit Switch (Opens 180°F)
11	1	R68AB0019	Double Pole Electric Heat Contactor - 50 Amp Resistive
DRAIN PAN			
12	1	R86FDA004	Galvanized G90 Drain Pan With Coating for F.D. 38
DX COIL			
13	1	R86BB0075C	3-Row, 10" x 49", A-Coil, 5/16"
CHILLED WATER COILS			
13	CHILLED WATER COILS - There are too many chilled water coil models to list. Contact factory sales rep to obtain the correct coil.		

Table 13: HE*1/HE*3-*-DC Electric Heat Air Handler Replacement Parts List**

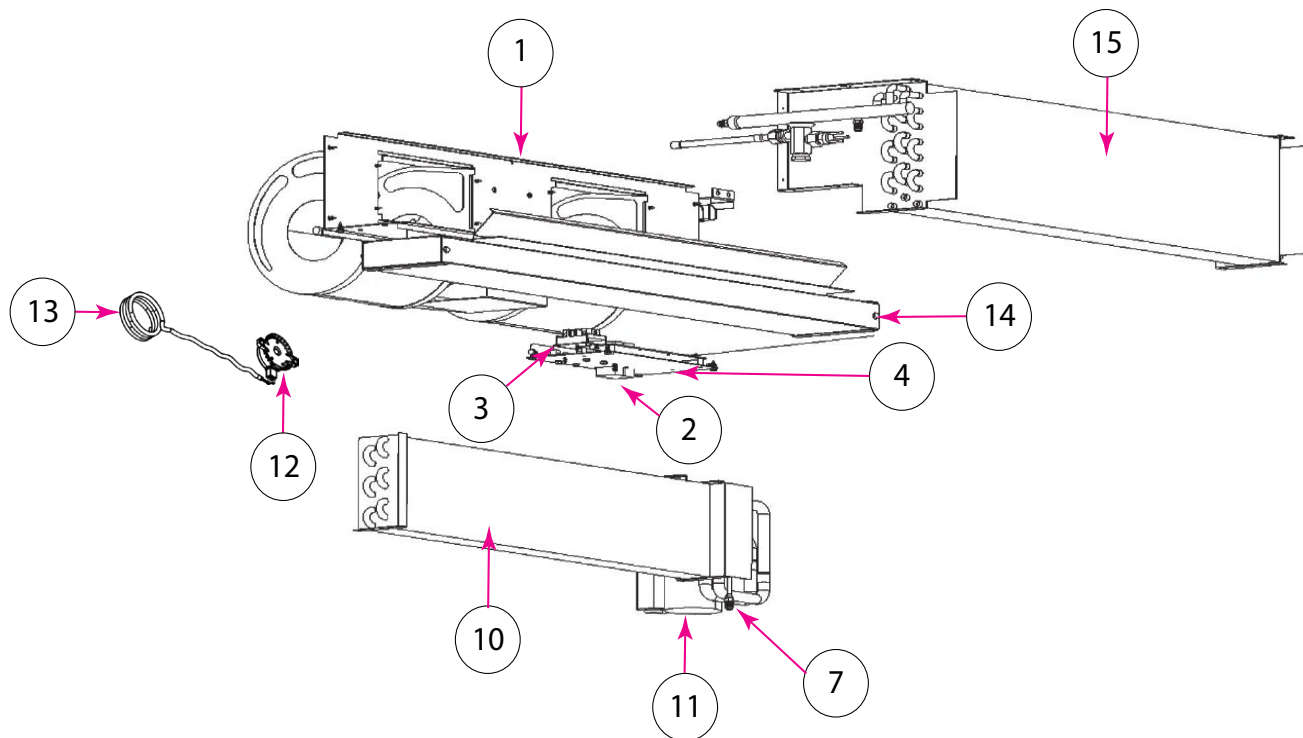

Figure 20: HE*2/HE*4-*AA Hydronic Heat Air Handler Replacement Parts Schematic**

HE*2/HE*4**-*AA HYDRONIC HEAT MODELS			
Item #	Qty.	Part #	Description
1	1		Blower Assembly - Contact factory rep to obtain the correct blower assembly..
2	1	R68AA0002	115-24V Transformer
3	1	R68DC0001	Ground Lug
4	1	R68AE0011	Hydronic Control Board for CT Blower Motors
5	1	R68DD0005	White Wire Freeze Protector
6	1	R66AB0006	Sensor Clip HW/AH
7	1	R74BA0004	Valve - Air Bleed Body
8	1	R74BA0005	Valve - Air Bleed Core
9	1	R74BB0001	1/2" Boiler Drain
10	1	R86BC0001	2 Row Hot Water Coil 6 x 27
11	1	R78AA0007	4 GPM Taco Circulating Pump 115V - 1/2" Inlet and Outlet
12	1	R68ALL001	R-32 Refrigerant Leak Sensor
12	1	R68ALL002	R-454B Refrigerant Leak Sensor
12	1	R68ALL003	R-32/R-454B Refrigerant (Dual Refrigerant)
13	1	R73BB0053	Refrigerant Leak Sensor Wire Harness
DRAIN PAN			
14	1	R86FDA001	Galvanized G90 Drain Pan With Coating for F.D. 30
DX COIL			
15	1	R86BB0072C	3 Row, A-Coil, 10" x 30", 3/8"
CHILLED WATER COILS			
15	CHILLED WATER COILS - There are too many chilled water coil models to list. Contact factory sales rep to obtain the correct coil.		

Table 14: HHE*2/HE*4-*AA Hydronic Heat Air Handler Replacement Parts List**

HE*2/HE*4***-BA HYDRONIC HEAT MODELS			
Item #	Qty.	Part #	Description
1	1		Blower Assembly - Contact factory rep to obtain the correct blower assembly.
2	1	R68AA0002	115-24V Transformer
3	1	R68DC0001	Ground Lug
4	1	R68AE0011	Hydronic Control Board for CT Blower Motors
5	1	R68DD0005	White Wire Freeze Protector
6	1	R66AB0006	Sensor Clip HW/AH
7	1	R74BA0004	Valve - Air Bleed Body
8	1	R74BA0005	Valve - Air Bleed Core
9	1	R74BB0001	1/2" Boiler Drain
10	1	R86BC0002	2 Row Hot Water Coil 6 x 35
11	1	R78AA0007	Standard 4 GPM Circulating Pump 115V - 1/2" Inlet and Outlet
11	1	R78AA0008	Optional 7 GPM Pump 115V - 3/4" Inlet and Outlet
12	1	R68ALL001	R-32 Refrigerant Leak Sensor
12	1	R68ALL002	R-454B Refrigerant Leak Sensor
12	1	R68ALL003	R-32/R-454B Refrigerant (Dual Refrigerant)
13	1	R73BB0053	Refrigerant Leak Sensor Wire Harness
DRAIN PAN			
14	1	R86FDA002	Galvanized G90 Drain Pan With Coating for F.D. 38
DX COIL			
15	1	R86BB0073C	3 Row, A-Coil, 10" x 38", 3/8"
CHILLED WATER COIL			
15	CHILLED WATER COILS - There are too many chilled water coil models to list. Contact factory sales rep to obtain the correct coil.		

Table 15: HE*2/HE*4*-BA Hydronic Heat Air Handler Replacement Parts List**

HE*2/HE*4***-CA HYDRONIC HEAT MODELS			
Item #	Qty.	Part #	Description
1	1		Blower Assembly - Contact factory rep to obtain the correct blower assembly.
2	1	R68AA0002	115-24V Transformer
3	1	R68DC0001	Ground Lug
4	1	R68AE0011	Hydronic Control Board for CT Blower Motors
5	1	R68DD0005	White Wire Freeze Protector
6	1	R66AB0006	Sensor Clip HW/AH
7	1	R74BA0004	Valve - Air Bleed Body
8	1	R74BA0005	Valve - Air Bleed Core
9	1	R74BB0001	1/2" Boiler Drain
10	1	R86BC0002	2 Row Hot Water Coil 6 x 35
11	1	R78AA0007	Standard 4 GPM Circulating Pump 115V - 1/2" Inlet and Outlet
11	1	R78AA0008	Optional 7 GPM Pump 115V - 3/4" Inlet and Outlet
12	1	R68ALL001	R-32 Refrigerant Leak Sensor
12	1	R68ALL002	R-454B Refrigerant Leak Sensor
12	1	R68ALL003	R-32/R-454B Refrigerant (Dual Refrigerant)
13	1	R73BB0053	Refrigerant Leak Sensor Wire Harness
DRAIN PAN			
14	1	R86FDA003	Galvanized G90 Drain Pan With Coating for F.D. 38
DX COIL			
15	1	R86BB0074C	3 Row, A-Coil, 10" x 42", 3/8"
CHILLED WATER COILS			
15	CHILLED WATER COILS - There are too many chilled water coil models to list. Contact factory sales rep to obtain the correct coil.		

Table 16: HE*2/HE*4*-CA Hydronic Heat Air Handler Replacement Parts List**

HE*2/HE*4**-*-DA HYDRONIC HEAT MODELS			
Item #	Qty.	Part #	Description
1	1		Blower Assembly - Contact factory rep to obtain the correct blower assembly.
2	1	R68AA0002	115-24V Transformer
3	1	R68DC0001	Ground Lug
4	1	R68AE0011	Hydronic Control Board for CT Blower Motors
5	1	R68DD0005	White Wire Freeze Protector
6	1	R66AB0006	Sensor Clip HW/AH
7	1	R74BA0004	Valve - Air Bleed Body
8	1	R74BA0005	Valve - Air Bleed Core
9	1	R74BB0001	1/2" Boiler Drain
10	1	R86BC0003	2 Row Hot Water Coil 6 x 46
11	1	R78AA0007	Standard 4 GPM Circulating Pump 115V - 1/2" Inlet and Outlet
11	1	R78AA0008	Optional 7 GPM Pump 115V - 3/4" Inlet and Outlet
12	1	R68ALL001	R-32 Refrigerant Leak Sensor
12	1	R68ALL002	R-454B Refrigerant Leak Sensor
12	1	R68ALL003	R-32/R-454B Refrigerant (Dual Refrigerant)
13	1	R73BB0053	Refrigerant Leak Sensor Wire Harness
DRAIN PAN			
14	1	R86FDA004	Galvanized G90 Drain Pan With Coating for F.D. 49
DX COIL			
15	1	R86BB0075C	3 Row, A-Coil, 10" x 49", 3/8"
CHILLED WATER COILS			
15	CHILLED WATER COILS - There are too many chilled water coil models to list. Contact factory sales rep to obtain the correct coil.		

Table 17: HE*2/HE*4-*-DA Hydronic Heat Air Handler Replacement Parts List**

When the air handler is at the end of its life and is being removed for replacement, proper procedures must be followed to assure the safety of the technician and building occupants due to the flammable refrigerant contained in the refrigeration system. Before performing this procedure, it is essential that the technician is completely familiar with the equipment and all its detail. It is recommended good practice that all refrigerants are recovered safely. Prior to the task being performed, an oil and refrigerant sample shall be taken in case analysis is required prior to re-use of recovered refrigerant. It is essential that electrical power is available before the task is commenced.

Decommissioning Procedure

- a) Become familiar with the equipment and its operation.
- b) Before attempting the procedure, ensure that:
 - mechanical handling equipment is available, if required, for handling refrigerant cylinders;
 - all personal protective equipment is available and being used correctly;
 - the recovery process is supervised at all times by a competent person;
 - recovery equipment and cylinders conform to the appropriate standards.
- c) Pump down the refrigerant into the outdoor unit, if possible, by closing the outdoor unit liquid service valve and energizing the compressor until the suction pressure is near atmospheric pressure. If pumping the system down is not possible due to an inoperable compressor, the refrigerant must be recovered.
- c) If a vacuum is not possible, make a manifold so that refrigerant can be removed from various parts of the system.
- e) Make sure that the recovery cylinder is situated on the scales before recovery takes place.
- f) Start the recovery machine and operate in accordance with instructions. (Also, refer to Refrigerant Recovery Requirements in the next column.)
- g) Do not overfill cylinders (no more than 80 % volume liquid charge).
- h) Do not exceed the maximum working pressure of the cylinder, even temporarily.
- i) When the cylinders have been filled correctly and the process completed, make sure that the cylinders and the equipment are removed from site promptly and all isolation valves on the equipment are closed off.
- j) Recovered refrigerant shall not be charged into another refrigerating system unless it has been cleaned and checked.
- k) Once all of the refrigerant has been pumped into the outdoor unit or has been recovered, disconnect the refrigerant lines from the air handler. Continuously flush or purge with inert gas when using a flame to open the circuit at the field refrigerant line connections.

- l) Turn the circuit breaker(s) serving the air handler in the main electrical panel to the OFF position. If a disconnect switch has been installed near the air handler, switch it to the OFF position.
- m) Disconnect all electrical wiring from the air handler.
- n) Once the refrigerant lines and electrical wiring have been disconnected from the air handler, remove the air handler from the property and dispose of it. Taking the air handler to recycling center is encouraged.
- o) Equipment shall be labelled stating that it has been decommissioned and emptied of refrigerant. The label shall be dated and signed. For appliances containing flammable refrigerants, ensure that there are labels on the equipment stating the equipment contains flammable refrigerant.

Refrigerant Recovery Requirements

When removing refrigerant from a system, either for servicing or decommissioning, it is recommended good practice that all refrigerants are removed safely.

When transferring refrigerant into cylinders, ensure that only appropriate refrigerant recovery cylinders are employed. Ensure that the correct number of cylinders for holding the total system charge is available. All cylinders to be used are designated for the recovered refrigerant and labelled for that refrigerant (i.e. special cylinders for the recovery of refrigerant). Cylinders shall be complete with pressure-relief valve and associated shut-off valves in good working order. Empty recovery cylinders are evacuated and, if possible, cooled before recovery occurs

The recovery equipment shall be in good working order with a set of instructions concerning the equipment that is at hand and shall be suitable for the recovery of the flammable refrigerant. If in doubt, the manufacturer should be consulted. In addition, a set of calibrated weighing scales shall be available and in good working order. Hoses shall be complete with leak-free disconnect couplings and in good condition.

The recovered refrigerant shall be processed according to local legislation in the correct recovery cylinder, and the relevant waste transfer note arranged. Do not mix refrigerants in recovery units and especially not in cylinders.

If compressors or compressor oils are to be removed, ensure that they have been evacuated to an acceptable level to make certain that flammable refrigerant does not remain within the lubricant. The compressor body shall not be heated by an open flame or other ignition sources to accelerate this process. When oil is drained from a system, it shall be performed safely.