

**Multi-Position DX and Chilled Water-Cooling With Electric Heating
Multi-Position Modular Air Handler With Electric Heating
MODELS: MSVT Series and MMVT Series With Single-Stage Cooling/Heat Pump Airflow
MSVE Series and MMVE Series With Single or Two-Stage Cooling/Heat Pump Airflow**

LIST OF SECTIONS

1 – General.....	1	9 – Field Installed Electric Heater Kits	25
2 – Safety	2	10 – Thermostat Wiring and Connections	26
3 – Location and Clearances.....	11	11 – Blower Performance	31
4 – Air Handler Orientation, Return Air, & Return Air Filters	12	12 – Motor Speed Selection and Air Handler Startup.....	33
5 – Installing the Air Handler.....	15	13 – Final System Checkout.....	34
6 – Refrigerant Piping, TXV, Condensate Piping , Chilled Water Piping.....	15	14 – Wiring Diagrams.....	36
7 – Refrig Leak Detection System Operation & Sensor Installation	18	15 – Minimum Conditioned Space and Airflow Tables.....	41
8 – Line Voltage Wiring.....	21		

LIST OF FIGURES

1 – Dimensions - MS Series With DX Cooling	8	21 – Control Box Circuit Breaker Location.....	24
2 – Dimensions –MS Series With Chilled Water Cooling	9	22 – Cabinet Wiring Entrances	26
3 – Dimensions - MM Series.....	10	23 – Low Voltage Connections: 1-Stage Heat & 1-Stage Cooling	27
4 – Clearance – Access for Service.....	12	24 – Low Voltage Connections: 1-Stage Heat & 1-Stage HP.....	27
5 – Closet Clearances	12	25 – Low Voltage Connections: 2-Stage Heat & 1-Stage Cooling.....	28
6 – Coil Top Cap Repositioning & Caulking for Horizontal Applications...	13	26 – Low Voltage Connections: 2-Stage Heat & 1-Stage HPt.....	28
7 – Indoor Coil Disassembly - Converting MS Series to Downflow	13	27 – Constant Torque Motor Terminals	33
8 – Indoor Coil Assembly - Converting MS Series to Downflow.....	14	28 – ECM Control Board Layout.....	33
9 – Combustible Floor Base Installation.....	14	29 – ECM Motor Control Plug Pin Positions	34
10 – Air Filter Base Accessory for 1” or 2” Air Filters.....	15	30 – Wiring Diagram: M*VE 18-72; ECM Motor; No Electric Htr.....	36
11 – Indoor Coil Below Outdoor Unit Piping.....	15	31 – Wiring Diagram: M*VE 18-72; ECM Motor; 5 kW Electric Htr.....	36
12 – Typical TXV Connections	17	32 – Wiring Diagram: M*VE 25-72; ECM Motor; 10 kW Electric Htr	37
13 – TXV Sensing Bulb Location.....	17	33 – Wiring Diagram: M*VE 37-72; ECM Motor; 15 kW Electric Htr	37
14 – TXV Bulb Placement.....	17	34 – Wiring Diagram: M*VE 42-72; ECM Motor; 20 kW Electric Htr	38
15 – Typical Condensate Trap.....	18	35 – Wiring Diagram: M*VT 18-72; C.T. Motor; No Electric Htr	38
16 – Refrigerant Leak Detection Sensor Location	19	36 – Wiring Diagram: M*VT 18-72; C.T. Motor; 5kW Electric Htr	39
17 – Refrigerant Leak Detection Wiring Connections	19	37 – Wiring Diagram: M*VT 25-72; C.T. Motor; 10kW Electric Htr.....	39
18 – Component Locations – Electric Heat Control Box	24	38 – Wiring Diagram: M*VT 25-72; C.T. Motor; 15kW Electric Htr.....	40
19 – Component Locations – No Heat Control Box	24	39 – Wiring Diagram: M*VT 37-72; C.T. Motor; 20kW Electric Htr.....	40
20 – Circuit Breaker Location on Front Panel	24		

LIST OF TABLES

1 – Air Handler Model Specifications	7	13 – Electric Heater Kit Model Numbers	25
2 – Air Handler Model Number Nomenclature.....	7	14 – Accessory Heater Kit Model Number Nomenclature	26
3 – Dimensional Data – MS Series With DX Cooling	8	15 – Low Voltage Wire Gauge and Maximum Lengths	26
4 – Dimensional Data - MS Series With Chilled Water Cooling	9	16 – Typ Heat/Cool T-stat Wire Colors & Low Voltage Connections	28
5 – Dimensional Data - MM Series.....	10	17 – Typ Heat Pump T-stat Wire Colors & Low Voltage Connections.....	29
6 – Altitude Adjustment Factors	11	18 – Blower Performance – Constant Torque Motors.....	31
7 – Clearances to Combustibles.....	12	19 – Blower Performance – ECM Motors.....	32
8 – Electrical Data: 18-36 kBTU–Single Branch Circuit	22	20 – Constant Torque Motor Terminal Connections	33
9 – Electrical Data: 37-72 kBTU–Single Branch Circuit	22	21 – ECM Motor Control Connector Terminal Descriptions.....	34
10 – Electrical Data: 25-36 kBTU–Dual Branch Circuit.....	23	22 – Min Conditioned Space & Min Airflow - R-454B Refrigerant.....	41
11 – Electrical Data: 37-72 kBTU–Dual Branch Circuit.....	23	23 – Min Conditioned Space & Min Airflow - R-32 Refrigerant.....	42
12 – Electric Heater Heating Capacities	23		

SECTION 1: GENERAL

The following list includes important facts and information regarding the air handler models covered in this manual.

1. Air handler is rated for 208/240 VAC at 60 Hertz.
2. Air handler size varies by model.
3. Air handler is designed for A/C or heat pump operation.
4. Air handler is designed for upflow, downflow and horizontal applications.
5. Air handler is listed by ETL in the United States and Canada.

WARNING

This air handler shall only be connected to an outdoor unit suitable for the same refrigerant.

This air handler (Model Series MSVT and MSVT only) is a partial unit air conditioner, complying with partial unit requirements of Standard UL 60335-2-40 / CSA C22.2 No. 60335-2-40, and must only be connected to other units that have been confirmed as complying to corresponding partial unit requirements of Standard UL 60335-2-40 / CSA C22.2 No. 60335-2-40.

SAVE THIS MANUAL FOR FUTURE REFERENCE



MS and MM Series Multi-Position Air Handlers



This is a safety alert symbol. When this symbol is seen on labels or in manuals, be alert to the potential for personal injury. Understand and pay particular attention to the signal words **DANGER**, **WARNING**, or **CAUTION**.

DANGER: Indicates an imminently hazardous situation, which if not avoided, **will result in death or serious injury**.

WARNING: Indicates a potentially hazardous situation, which if not avoided, **could result in death or serious injury**.

CAUTION: Indicates a potentially hazardous situation, which if not avoided, **may result in minor or moderate injury**. It is also used to alert against unsafe practices and hazards involving property damage.

WARNING

Improper installation may create a condition where the operation of the product could cause personal injury or property damage.

Improper installation, adjustment, alteration, service or maintenance can cause injury or property damage. Refer to this manual for assistance; or for additional information consult a qualified contractor, installer, or service agency.

WARNING

FIRE OR ELECTRICAL HAZARD

Failure to follow the safety warnings exactly could result in serious injury, death, or property damage.

A fire or electrical hazard may result causing property damage, personal injury or loss of life.

CAUTION

This product must be installed in strict compliance with the installation instructions and any applicable local, state, and national codes including, but not limited to, building, electrical, and mechanical codes.

IMPORTANT

The Clean Air Act of 1990 bans the international venting of refrigerant (CFC's and HFC's) as of July 1, 1992. Approved methods of reclaiming must be followed. Fines and/or incarceration may be levied for non-compliance.

WARNING

RISK OF FIRE

This unit is equipped with a refrigerant leak detection system for safety and with electrically powered safety measures. To be effective, the unit must be electrically powered at all times after installation, other than when servicing..

WARNING

RISK OF FIRE

Refer to Tables 22 and 23 for the minimum floor area of the conditioned space served by this air-handler due to the use of an A2L class flammable refrigerant.

WARNING



RISK OF FIRE

Do not use means to accelerate the defrosting process or to clean, other than those recommended by the manufacturer.

The appliance shall be stored in a room without continuously operating ignition sources (e.g.: open flames, an operating gas appliance, or an operating electric heater).

Do not pierce or burn.

Be aware that refrigerants may not contain an odor.

Safety Requirements

1. This air handler should be installed in accordance with all national and local building/safety codes and requirements, local plumbing or waste-water codes, and other applicable codes. In the absence of local codes, install in accordance with the following codes.

- Standard for the Installation of Air Conditioning and Ventilating Systems (NFPA 90A)
- Standard for the Installation of Warm Air Heating and Air Conditioning Systems (NFPA 90B)
- National Electrical Code (NFPA 70)
- Canadian Electrical Code, Part I (CSA C22.2) or ANSI/NFPA No. 70
- All local codes (State, City, and Township)

NOTE: All applicable codes take precedence over any recommendation made in these instructions. Mortex Products, Inc. assumes no responsibility for units installed in violation of any code or regulation.

2. Refer to the unit rating plate for the air handler model number, and then see the dimensions page of this instruction for return air plenum dimensions in Figures 1 and 2 and Tables 3 and 4. The plenum must be installed according to the above listed codes or the instructions in this manual.
3. Refer to the dimensions page of this manual and Figure 9 for the proper duct connector or combustible floor base for downflow applications. The duct connector and combustible floor base installation must be installed according to the instructions in this manual.
4. These models are not ETL listed or approved for installation into a Manufactured (Mobile) Home.
5. Provide clearances from combustible materials as listed under **Clearances to Combustibles**.
6. Provide clearances for servicing ensuring service access is allowed for the control box, electric heating elements, and the blower.
7. Check the rating plate and the power supply to be sure the electrical characteristics match.
8. Failure to carefully read and follow all instructions in this manual can result in malfunction of the air handler, death, personal injury, and/or property damage.
9. The air handler must be installed so the electrical components are protected from water.
10. Installing and servicing heating/cooling equipment can be hazardous due to electrical components.
11. Only trained and qualified personnel should install repair or service heating/cooling equipment. Untrained service personnel can perform basic maintenance functions such as cleaning of exterior surfaces and replacing the air filters. Observe all precautions in the manuals and on the attached labels when working on this air handler.
12. These instructions cover minimum requirements and conform to existing national standards and safety codes. In some instances, these instructions exceed certain local codes and ordinances, especially those who have not kept up with changing home and/ or HUD construction practices. These instructions are to be followed and are the minimum requirement for a safe installation.
13. The size of the heating and cooling system should be based on an acceptable heat loss/heat gain for the structure. ACCA, Manual J or other approved methods may be used.
14. Air handler must not be operated with the access panels removed.
15. The air handler must be attached to the supporting building structure with screws instead of relying on adhesive.
16. This air handler is for use at elevations of 10,000 ft (3,048m) or less.
17. This air handler is not to be used by persons (including children) with reduced physical, sensory or mental capabilities, or lack of experience and knowledge, unless they have been given supervision or instruction concerning use of this air handler by a person responsible for their safety. Children must not be allowed to play with this air handler.
18. Check the rating plate and power supply to be sure that the air handler is connected to a nominal 208/240 VAC, 1 Phase, 60-Hertz power supply. **DO NOT CONNECT THIS AIR HANDLER TO A 50 HZ POWER SUPPLY OR A VOLTAGE ABOVE 250 VOLTS.**
19. This air handler is shipped from the factory for 240VAC applications. The transformer must be reconfigured for 208VAC

applications using the following steps to assure adequate control voltage (24VAC).

- a. Remove the zip tie from the transformer wire bundle that secures the BLACK, ORANGE and WHITE wires together.
 - b. Disconnect the WHITE (240VAC) transformer primary wire with an insulated terminal from the load side of the circuit breaker and connect the ORANGE (208VAC) transformer primary wire with an insulated terminal to the same terminal on the circuit breaker.
 - c. Secure the loose BLACK, ORANGE and WHITE wires to the transformer wire bundle with a zip tie.
20. If the main electrical panel supplying electrical power to the air handler utilizes circuit breakers, the circuit breakers must be HACR type.
 21. A means of disconnecting all poles of the incoming line voltage power to the air handler must be provided in the fixed field wiring within sight of the air handler unless the air handler is equipped with integral circuit breaker(s) with their ON/OFF lever(s) located on the outside of the air handler which can be used to disconnect line voltage electrical power to the air handler.
 22. Ground connections must be securely fastened to the control box and ground wires must be secure.
 23. Check that cabling will not be subject to wear, corrosion, excessive pressure, vibration, sharp edges or any other adverse environmental effects. The check shall also take into account the effects of aging or continual vibration from sources such as compressors or fans.
 24. Installation, servicing and maintenance must only be performed by qualified service personnel that are licensed by the state to install, service, and repair HVAC equipment and those who have successfully completed a course in handling, installing, commissioning, maintenance, servicing, repairing, decommissioning, and disposing of equipment using a flammable refrigerant offered by an accredited national training organization or the manufacturer of the equipment.
 25. The use of dropped ceilings for return air is not permitted for this air handler.
 26. **Safely Commissioning of the System**
 - Ensure that the floor area is sufficient for the refrigerant charge or that the ventilation duct is assembled in a correct manner.
 - Connect the pipes and carry out a leak test before charging with refrigerant.
 - Check safety equipment before putting into service.
 27. **Approved Auxiliary Devices**
The following list of auxiliary electric heater kits are approved by the manufacturer of this air handler.

BSEHK05C	BMEHK15C	BLEHK15C
BSEHK10C	BMXHK05C	BLEHK20C
BSXHK05C	BMXHK10C	BLXHK05C
BSXHK10C	BMXHK15C	BLXHK10C
BMEHK05C	BLEHK05C	BLXHK15C
BMEHK10C	BLEHK10C	BLXHK20C

Proper Safe Working Procedures for Equipment Using Flammable Refrigerants

Prior to beginning work on systems containing flammable refrigerants, safety checks are necessary to ensure that the risk of ignition is minimized. For repair to the refrigerating system, the following steps must be completed prior to conducting work on the system.

- 1) Work shall be undertaken under a controlled procedure so as to minimize the risk of a flammable gas or vapor being present while the work is being performed.
- 2) All maintenance staff and others working in the local area shall be instructed on the nature of work being carried out. Work in confined spaces shall be avoided.
- 3) The area shall be checked with an appropriate refrigerant detector prior to and during work, to ensure the technician is aware of potentially toxic or flammable atmospheres. Ensure that the leak detection equipment being used is suitable for use with all applicable refrigerants, (i.e.: non-sparking, adequately sealed or intrinsically safe).
- 4) If any hot work is to be conducted on the refrigerating equipment or any associated parts, appropriate fire extinguishing equipment shall be available to hand. Have a dry powder or CO₂ fire extinguisher adjacent to the charging area.
- 5) No person performing work on to a refrigerating system which involves exposing any pipe work shall use any sources of ignition in such a manner that it may lead to the risk of fire or explosion. All possible ignition sources, including cigarette smoking, should be kept sufficiently far away from the site of installation, repairing, removing and disposal, during which refrigerant can possibly be released to the surrounding space. Prior to work taking place, the area around the equipment is to be surveyed to make sure that there are no flammable hazards or ignition risks. "No Smoking" signs shall be displayed.
- 6) Ensure that the area is in the open or that it is adequately ventilated before breaking into the system or conducting any hot work. A degree of ventilation shall continue during the period that the work is being performed. The ventilation should safely disperse any released refrigerant and preferably expel it externally into the atmosphere.
- 7) Where electrical components are being changed, they shall be fit for the purpose and to the correct specification. At all times, the manufacturer's maintenance and service guidelines shall be followed. If in doubt, consult the manufacturer's technical department for assistance.
- 8) The following checks shall be applied to installations using flammable refrigerants:
 - the actual refrigerant charge is in accordance with the room size within which the refrigerant containing parts are installed;
 - marking to the equipment continues to be visible and legible. Markings and signs that are illegible shall be corrected;
 - refrigerating pipe or components are installed in a position where they are unlikely to be exposed to any substance which may corrode refrigerant containing components, unless the components are constructed of materials which are inherently resistant to being corroded or are suitably protected against being so corroded.

9) Detection of Flammable Refrigerants

Under no circumstances shall potential sources of ignition be used in the searching for or detection of refrigerant leaks. A halide torch (or any other detector using a naked flame) shall not be used.

The following leak detection methods are deemed acceptable for all refrigerant systems.

Electronic leak detectors may be used to detect refrigerant leaks but, in the case of flammable refrigerants, the sensitivity may not be adequate, or may need re-calibration. (Detection equipment shall be calibrated in a refrigerant-free area.) Ensure that the detector is not a potential source of ignition and is suitable for the refrigerant used. Leak detection equipment shall be set at a percentage of the LFL of the refrigerant and shall be calibrated to the refrigerant employed, and the appropriate percentage of gas (25 % maximum) is confirmed.

Leak detection fluids are also suitable for use with most refrigerants, but the use of detergents containing chlorine shall be avoided as the chlorine may react with the refrigerant and corrode the copper pipe-work.

NOTE: Examples of leak detection fluids are:

- bubble method,
- fluorescent method agents.

If a leak is suspected, all naked flames shall be removed/ extinguished.

If a leakage of refrigerant is found which requires brazing, all of the refrigerant shall be recovered from the system, or isolated (by means of shut off valves) in a part of the system remote from the leak. Removal of refrigerant shall be according to Step 10 below.

10) Removal and Evacuation

When breaking into the refrigerant circuit to make repairs or for any other purpose, conventional procedures shall be used. However, for flammable refrigerants, it is important that best practice be followed since flammability is a consideration. The following procedure shall be adhered to:

- safely remove refrigerant following local and national regulations;
- evacuate;
- purge the circuit with inert gas (optional for A2L refrigerants);
- evacuate (optional for A2L refrigerants);
- continuously flush or purge with inert gas when using flame to open circuit; and
- open the circuit.

The refrigerant charge shall be recovered into the correct recovery cylinders if venting is not allowed by local and national codes. For appliances containing flammable refrigerants, the system shall be purged with oxygen-free nitrogen to render the appliance safe for flammable refrigerants. This process might need to be repeated several times. Compressed air or oxygen shall not be used for purging refrigerant systems. (Also see **Refrigerant Recovery Requirements** below.)

For appliances containing flammable refrigerants, purging shall be achieved by breaking the vacuum in the system with oxygen-free nitrogen and continuing to fill until the working pressure is achieved, then venting to atmosphere, and finally pulling down to a vacuum (optional for A2L refrigerants). This process shall be repeated until no refrigerant is within the system (optional for

A2L refrigerants). When the final oxygen-free nitrogen charge is used, the system shall be vented down to atmospheric pressure to enable work to take place.

The outlet for the vacuum pump shall not be close to any potential ignition sources, and ventilation shall be available.

11) Charging Procedures

In addition to conventional charging procedures, the following requirements shall be followed.

- Ensure that contamination of different refrigerants does not occur when using charging equipment. Hoses or lines shall be as short as possible to minimize the amount of refrigerant contained in them.
- Cylinders shall be kept in an appropriate position according to the instructions.
- Ensure that the refrigerating system is earthed prior to charging the system with refrigerant.
- Label the system when charging is complete (if not already).
- Extreme care shall be taken not to overfill the refrigerating system.
- Prior to recharging the system, it shall be pressure-tested with the appropriate purging gas. The system shall be leak-tested on completion of charging but prior to commissioning. A follow up leak test shall be carried out prior to leaving the site.

12) Refrigerant Recovery Requirements

When removing refrigerant from a system, either for servicing or decommissioning, it is recommended good practice that all refrigerants are removed safely.

When transferring refrigerant into cylinders, ensure that only appropriate refrigerant recovery cylinders are employed. Ensure that the correct number of cylinders for holding the total system charge is available. All cylinders to be used are designated for the recovered refrigerant and for that refrigerant (i.e. special cylinders for the recovery of refrigerant). Cylinders shall be complete with pressure-relief valve and associated shut-off valves in good working order. Empty recovery cylinders are evacuated and, if possible, cooled before recovery occurs.

The recovery equipment shall be in good working order with a set of instructions concerning the equipment that is at hand and shall be suitable for the recovery of the flammable refrigerant. If in doubt, the manufacturer should be consulted. In addition, a set of calibrated weighing scales shall be available and in good working order. Hoses shall be complete with leak-free disconnect couplings and in good condition.

The recovered refrigerant shall be processed according to local legislation in the correct recovery cylinder, and the relevant waste transfer note arranged. Do not mix refrigerants in recovery units and especially not in cylinders.

If compressors or compressor oils are to be removed, ensure that they have been evacuated to an acceptable level to make certain that flammable refrigerant does not remain within the lubricant. The compressor body shall not be heated by an open flame or other ignition sources to accelerate this process. When oil is drained from a system, it shall be carried out safely.

WARNING

FIRE HAZARD

For air handlers using A2L refrigerants connected via an air duct system to one or more rooms, auxiliary devices which may be a potential ignition source shall not be installed in the duct work. Examples of such potential ignition sources are hot surfaces with a temperature exceeding 1290°F (700°C) and electric switching devices.

WARNING

FIRE HAZARD

For air handlers using A2L refrigerants connected via an air duct system to one or more rooms, only auxiliary devices approved by the air handler manufacturer or declared suitable with the refrigerant shall be installed in connecting ductwork.

WARNING

Always shut off electricity at the disconnect switch or turn off the circuit breakers in the main electrical panel before performing any service on this air handler

WARNING

FIRE HAZARD

For air handlers using A2L refrigerants connected via an air duct system to one or more rooms with a floor area less than shown in Tables 22 and 23 based on the total system refrigerant charge, those rooms shall be without continuously operating open flames (e.g.: an operating gas appliance) or other potential ignition sources (e.g.: an operating electric heater, hot surfaces). A flame-producing device may be installed in the same space if the device is provided with an effective flame arrest.

WARNING

RISK OF FIRE – FLAMMABLE REFRIGERANT APPLICATIONS

If any refrigerating circuit contains more than 62.6 oz (1.776 kg) of R-454B refrigerant or more than 64.6 oz (1.836 kg) of R-32 refrigerant, an unventilated area where the air-handler using a flammable refrigerant is installed shall be so constructed that should any refrigerant leak, it will not stagnate and create a fire or explosion hazard.



WARNING

RISK OF FIRE – FLAMMABLE REFRIGERANT APPLICATIONS

The ductwork connected to this air-handler shall not contain an ignition source.

Auxiliary devices which may be a potential ignition source shall not be installed in the duct work. Examples of such potential ignition sources are hot surfaces with a temperature exceeding 1292°F (700°C) and electric switching devices.

Only auxiliary devices approved by the air-handler manufacturer or declared suitable with the refrigerant shall be installed in connecting ductwork.

GENERAL INFORMATION

This single piece air handler provides the flexibility for installation in any upflow, downflow, or horizontal application. The versatile models may be used with or without electric heat. The direct-drive variable speed ECM and 5-speed constant torque motors provide a selection of air-flow volume to match any application. The air handler can be positioned for bottom air return in the upflow position, top air return in the downflow position, or air return through the end of the air handler in the horizontal position.

NOTE: Refer to the instructions in this manual for the proper downflow conversion kit and instructions on the proper conversion to the downflow configuration.

Maximum Operating Temperature for Heat Pump Applications

For heat pump applications, the maximum outdoor temperature recommended by the manufacturer while the system is operating in the heating mode is 70°F/23.9°C.

Inspection

As soon as the air handler is received, it should be inspected for possible damage during transit. If damage is evident, the extent of the damage should be noted on the carrier's freight bill. A separate request for inspection by the carrier's agent should be made in writing. Before installing the air handler, check the cabinet for screws or bolts which may have loosened in transit. There are no shipping or spacer brackets which need to be removed before startup.

See local distributor for more information. Mortex Products, Inc assumes no liability for freight damage.

Also check to be sure all accessories such as heater kits, and coils are available. Installation of these accessories should be accomplished before the air handler is set in place or the connecting of the wiring, electric heat, ducts or piping.

Models	M***18,24	M***25,30,36	M***37,42,48,60	M***72
Available Electric Heat kW	5,10	5,10,15	5,10,15,20	5,10,15,20
Blower Size (D x W)	9 x 6 (M*VE) 10 x 7 (M*VT)	10 x 7 (M*VE) 10 x 8 (M*VT)	12 x 9 (M*VE & M*VT)	12 x 10 (M*VE & M*VT)
Unit Voltage	208/240V, 60 HZ, 1 PH			
Max. External SP (Duct), In. W.C.	0.50			
Thermostat Circuit	24 VAC, 60 Hz, 40VA			

Table 1: Air Handler Model Specifications

* S or M

*** SVE, SVT, MVE, or MVT

Available Blower Motors

1. 5 SPD CONSTANT TORQUE MOTOR
2. VARIABLE SPEED ECM MOTOR

MODEL NUMBER NOMENCLATURE						
MS	VT	36	15	B	862T	AA
I	II	III	IV	V	VI	VII
I	Series MS = Multi-Position Single-Piece MM = Multi-Position Modular					
II	Motor Type VT = Variable Constant Torque VE = Variable Speed ECM					
III	Unit Size (Capacity in MBTUH) 12 through 24 - Small Cabinet 25 through 36 - Medium Cabinet 37 through 72 - Large Cabinet					
IV	Heating Configuration 00 = Cooling Only 05 = 5 kW Electric Heating Capacity 10 = 10 kW Electric Heating Capacity 15 = 15 kW Electric Heating Capacity 20 = 20 kW Electric Heating Capacity					
V	Air Handler Voltage B = 208/240					
VI	SUMMIT Evaporator Coil Configuration 862P = DX Coil Geometry, Metering Device, and Refrigerant 8K2N = CW Coil Geometry, No Metering Device					
VII	Option Code AA = Standard Factory Options					

Table 2: Electric Heat Air Handler Model Number Nomenclature

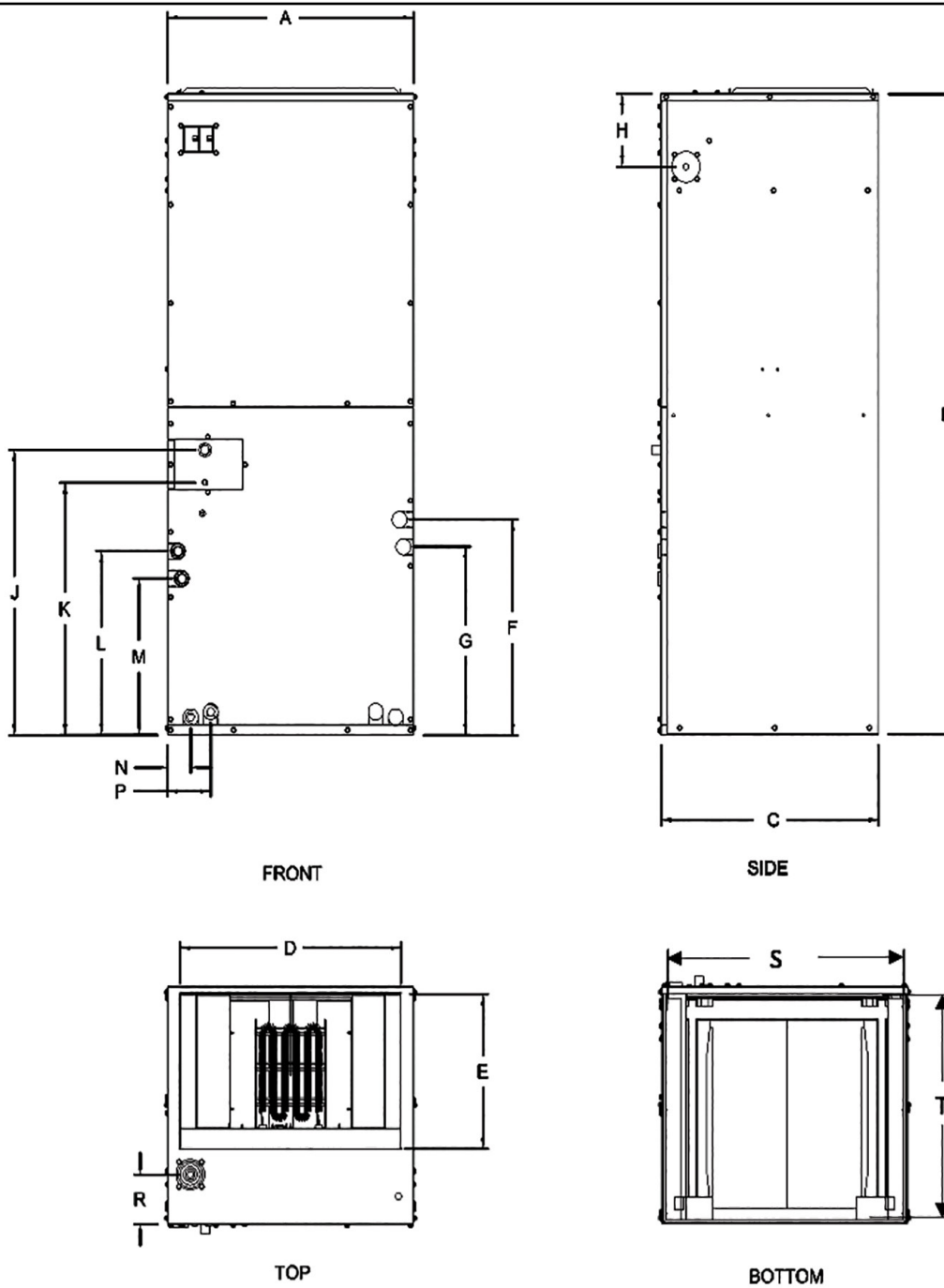

Figure 1: Dimensional Data - MS Series - DX Cooling With Or Without Electric Heat

Model	A	B	C	D	E	F	G	H	J	K	L	M	N	P	R	S	T
MS**18, 24	17.50	42.80	21.00	15.61	12.50	13.50	11.00	6.75	16.75	13.79	10.81	8.25	2.00	4.05	5.00	16.50	19.75
MS**25, 30, 36	21.00	48.03	21.00	19.00	12.50	15.42	13.00	6.75	20.40	17.40	12.42	10.05	2.30	4.35	5.00	20.00	19.75
MS**37, 42, 48, 60, 72	24.50	58.86	21.75	22.06	14.25	20.46	17.25	6.75	26.20	23.20	16.84	14.34	2.30	4.35	4.50	23.50	20.75

Table 3: Dimension Data - MS Series - DX Cooling With & Without Electric Heat

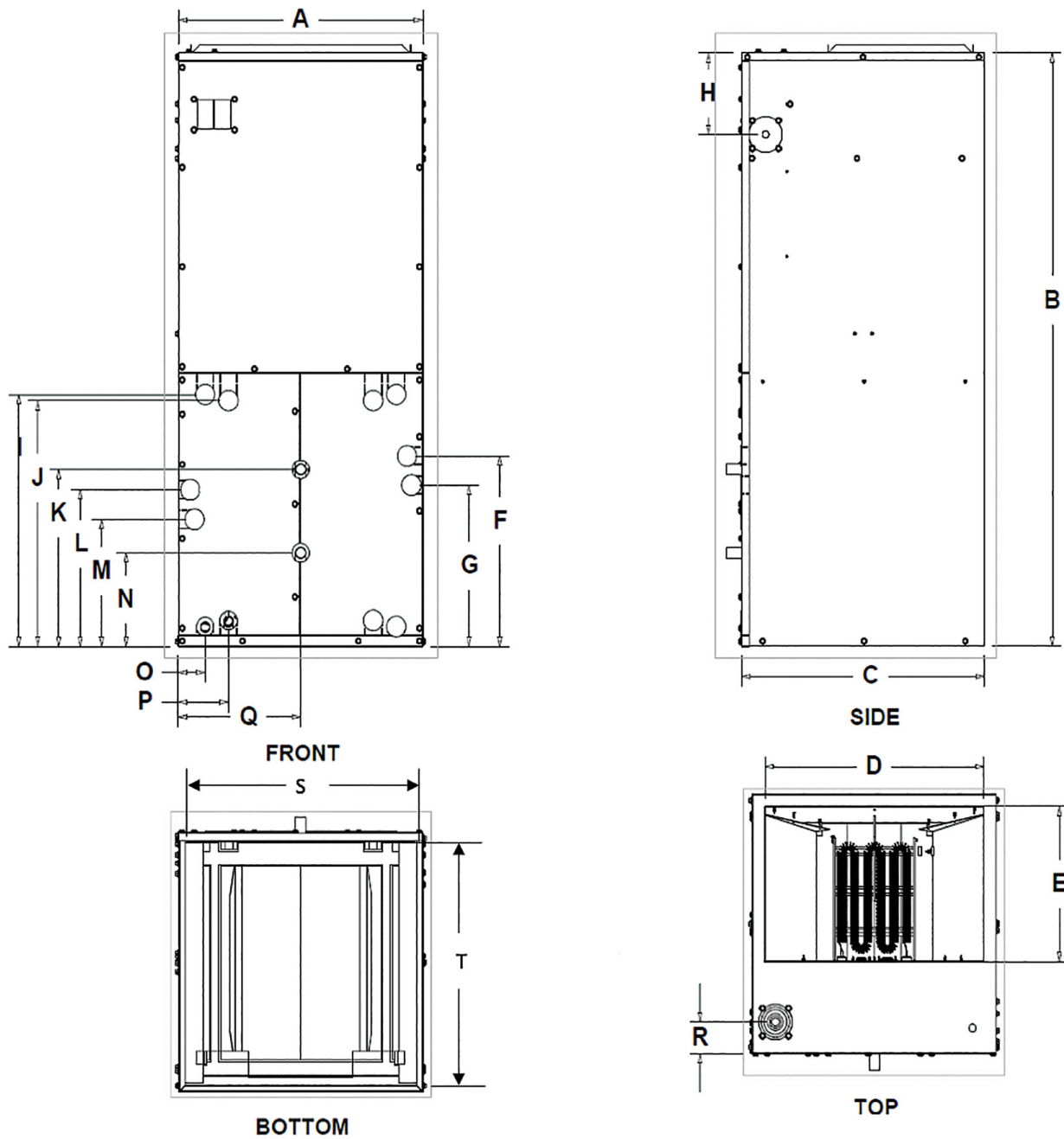
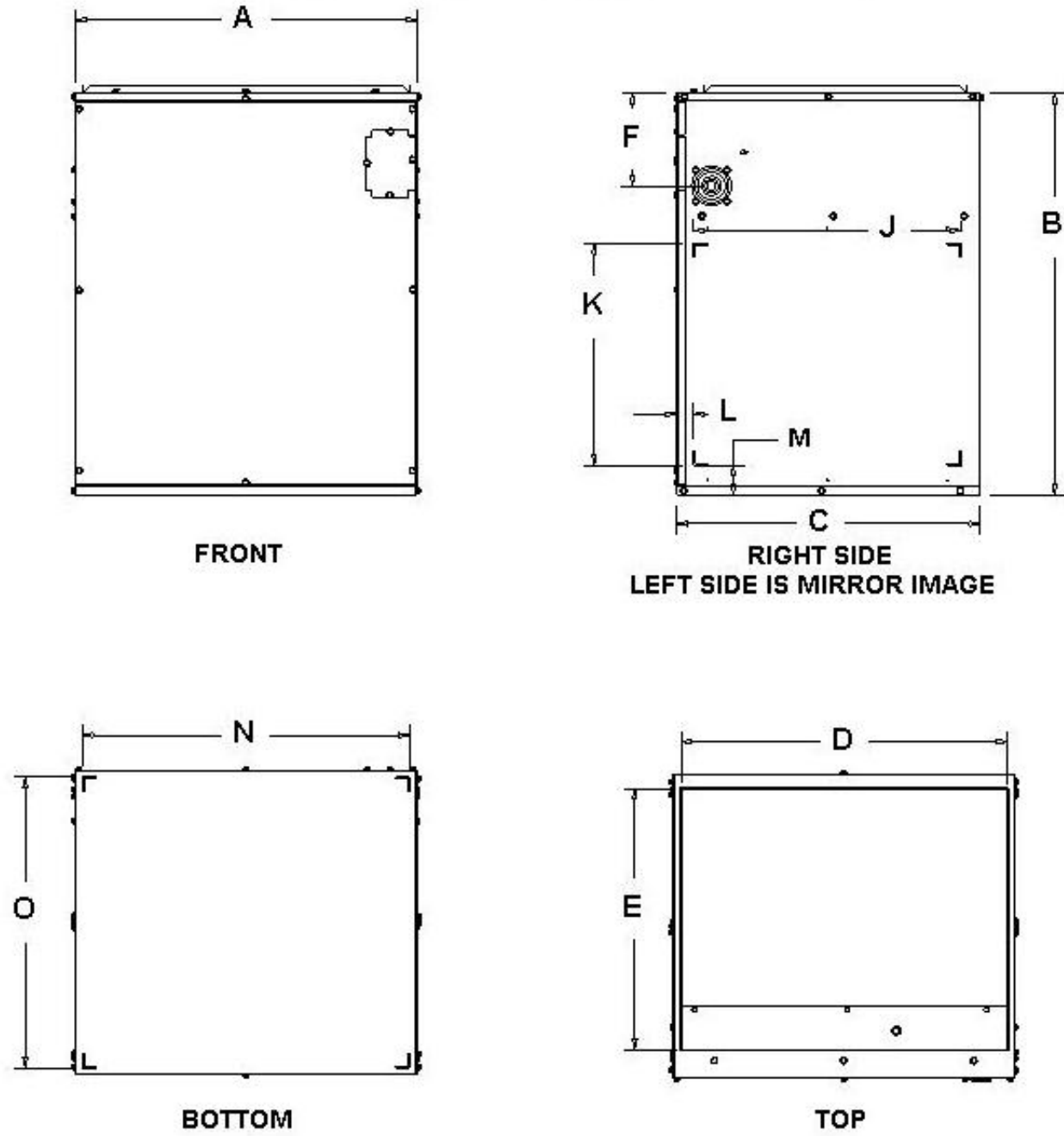

Figure 2: Dimensional Data - MS Series - Chilled Water Cooling With & Without Electric Heat

Model	A	B	C	D	E	F	G	H	I	J	K	L	M	N	O	P
MS**18, 24	17.50	42.80	21.00	15.61	12.42	13.50	11.00	6.75	16.82	16.30	13.52	10.81	8.25	4.85	2.00	4.05
MS**25, 30, 36	21.00	48.00	21.00	19.00	12.56	15.41	13.00	6.75	20.38	19.88	14.32	12.66	10.29	7.55	2.30	4.35
MS**37, 42, 48, 60, 72	24.50	58.86	21.75	22.06	14.31	19.71	17.25	6.75	28.36	27.86	19.68	16.84	14.34	10.31	2.30	4.35
Model	Q	R	S	T												
MS**18, 24	8.75	5.00	16.50	19.75												
MS**25, 30, 36	10.50	5.00	20.00	19.75												
MS**37, 42, 48, 60, 72	12.25	4.50	23.50	20.75												

Table 4: Dimensional Data- MS Series - Chilled Water Cooling With & Without Electric Heat

DIMENSIONAL DATA MODULAR ELECTRIC HEAT



FRONT

**RIGHT SIDE
LEFT SIDE IS MIRROR IMAGE**

BOTTOM

TOP

Figure 3: Dimensional Data – Modular MM Series With & Without Electric Heat

Model	A	B	C	D	E	F	J	K	L	M	N	O
MM**18, 24	17.50	29.00	21.00	15.63	12.50	6.75	19.25	16.50	1.125	1.9375	16.50	20.00
MM**30, 36	21.00	29.00	21.00	19.00	12.50	6.75	19.25	16.50	1.125	1.9375	20.00	20.00
MM**37, 42, 48, 60, 72	24.50	29.00	21.75	22.25	14.25	6.75	19.25	16.50	1.125	1.9375	23.00	20.94

Table 5: Dimensional Data – Modular MM Series With & Without Electric Heat

⚠ WARNING

RISK OF FIRE

Refer to Tables 22 and 23 for the minimum floor area of the conditioned space served by this air-handler due to the use of an A2L class flammable refrigerant

⚠ WARNING

RISK OF FIRE – FLAMMABLE REFRIGERANT APPLICATIONS

If any refrigerating circuit contains more than 62.6 oz (1.776 kg) of R-454B refrigerant or more than 64.6 oz (1.836 kg) of R-32 refrigerant, an unventilated area where the air-handler using a flammable refrigerant is installed shall be so constructed that should any refrigerant leak, it will not stagnate and create a fire or explosion hazard.

If the air duct system connected to one or more rooms with an area less than the minimum conditioned space floor area shown in Tables 22 and 23 based on the total system refrigerant charge, that room shall be without continuously operating open flames (e.g.: an operating gas appliance) or other potential ignition sources (e.g.: an operating electric heater, hot surfaces). A flame-producing device may be installed in the same space if the device is provided with an effective flame arrest.

When flammable A2L class refrigerants are used, the minimum floor area of the conditioned space the air handler serves must comply with Tables 22 and 23 to allow a refrigerant leak to disperse and be diluted with air to eliminate the risk of the refrigerant igniting and causing an explosion and/or fire. The minimum floor area must be corrected by an altitude adjustment factor based on the building site ground level altitude. See Table 6 for the altitude adjustment factor for various altitudes and refer to the example below for how to apply the altitude adjustment factor.

Example:

Total System Charge = 2.6 kg of R-454B
 Altitude = 2400 m
 Min. Conditioned Floor Area (MCFA) from Table 22 = 7.97 m²
 Altitude Adjustment Factor (AF) from Table 6 = 1.24
 Adjusted MCFA = MCFA x AF
 Adjusted MCFA (@ 2400 m. altitude) = 7.97 m² x 1.24 = 9.88 m²

Altitude Correction Factors									
Altitude (m)	0	100	200	300	400	500	600	700	800
Altitude (ft)	0	328	656	984	1312	1640	1969	2297	2625
AF	1.00	1.01	1.02	1.02	1.03	1.04	1.05	1.06	1.07
Altitude (m)	900	1000	1100	1200	1300	1400	1500	1600	1700
Altitude (ft)	2953	3281	3609	3937	4265	4593	4921	5249	5577
AF	1.08	1.09	1.10	1.11	1.12	1.13	1.14	1.15	1.16
Altitude (m)	1800	1900	2000	2100	2200	2300	2400	2500	2600
Altitude (ft)	5906	6234	6562	6890	7218	7546	7874	8202	8530
AF	1.17	1.18	1.19	1.20	1.21	1.22	1.24	1.25	1.26
Altitude (m)	2700	2800	2900	3000	3100	3200	3400	3600	3700
Altitude (ft)	8858	9186	9514	9842	10171	10499	11155	11811	12139
AF	1.27	1.29	1.30	1.31	1.33	1.34	1.37	1.40	1.42

Table 6: Altitude Adjustment Factors

LOCATION

Access for servicing is an important factor in the location of any air handler. Provide a minimum of 30 inches in front of the air handler for access to the control box, heating elements, blower, and air filters. This access may be provided by a closet door or by locating the air handler so that a wall or partition is not less than 30 inches from the front access panel. As the location is usually predetermined, check with owner's or dealer's installation plans. If a location has not been decided, consider the following in choosing a suitable location.

1. Select a location with adequate structural support, space for service access, clearance for return and supply duct connections.
2. Normal operating sound levels may be objectionable if the air handler is placed directly over or under some rooms such as bedrooms, study, etc.
3. It is best to locate the air handler so that supply air ducts are about the same length and the return air ducts are about the same length to provide even air distribution of supply and return air to and from the living spaces.
4. Locate air handler where electrical supply wiring can be easily routed to the main electrical panel and where electrical wiring will not be damaged.
5. Locate air handler where thermostat wiring can be easily routed to the thermostat and where the wiring will not be damaged.
6. Locate air handler where refrigerant lines can be easily routed from the indoor coil to the outdoor unit.
7. Locate the air handler where condensate lines can be easily routed to an available drain or outside. Be sure to route condensate drain piping so as not to obstruct access to the air filter.
8. When the coil is installed in a draw-through configuration as in this air handler, a negative pressure is created in the condensate drain system. To assure proper condensate drainage and to prevent condensate from being drawn into the blower, it is recommended that a trap be installed in the primary (main) and secondary (overflow) drain lines. Refer to the **CONDENSATE DRAIN PIPING** section and Figure 15 in this manual. If the secondary drain is not used, it must be capped.
9. The draw-through design can also cause exterior surface of cabinet to sweat when air handler is installed in a non conditioned space such as an attic or garage. The installer must provide protection such as full-size auxiliary drain pan under all air handlers installed in a non-conditioned space to prevent damage from condensation runoff. Some states, cities and counties require additional insulation to be installed on the exterior casing of the air handler to prevent sweating. Refer to the state, city, county or local code for insulation requirement to

be sure the installation is in compliance. In the absence of local code, it is recommended that air handlers installed in non-conditioned spaces be insulated on the exterior of the entire cabinet including the front access panel with one (1) inch thick fiberglass that has a vapor barrier on the outside.

CLEARANCES

This air handler is approved for zero (0) inches clearance to combustible material on any part of the air handler exterior casing. Refer to Table 7 and Figures 4 and 5 for clearance to combustibles and for service access clearances.

MODEL	TOP (in)	BACK (in)	SIDES (in)	FRONT OF FURNACE		DUCT (in)
				ALCOVE (in)	CLOSET (in)	
ELECTRIC HEAT	0	0	0	30	6	1

Table 7: Clearances to Combustibles

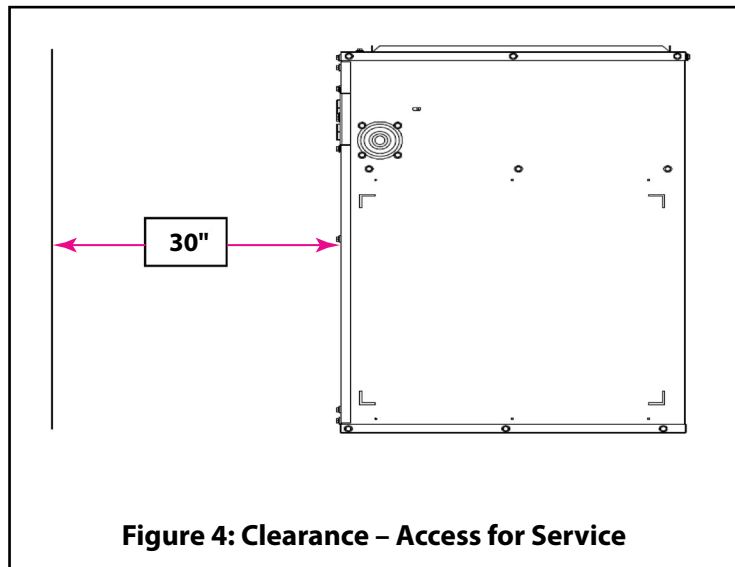

Figure 4: Clearance - Access for Service

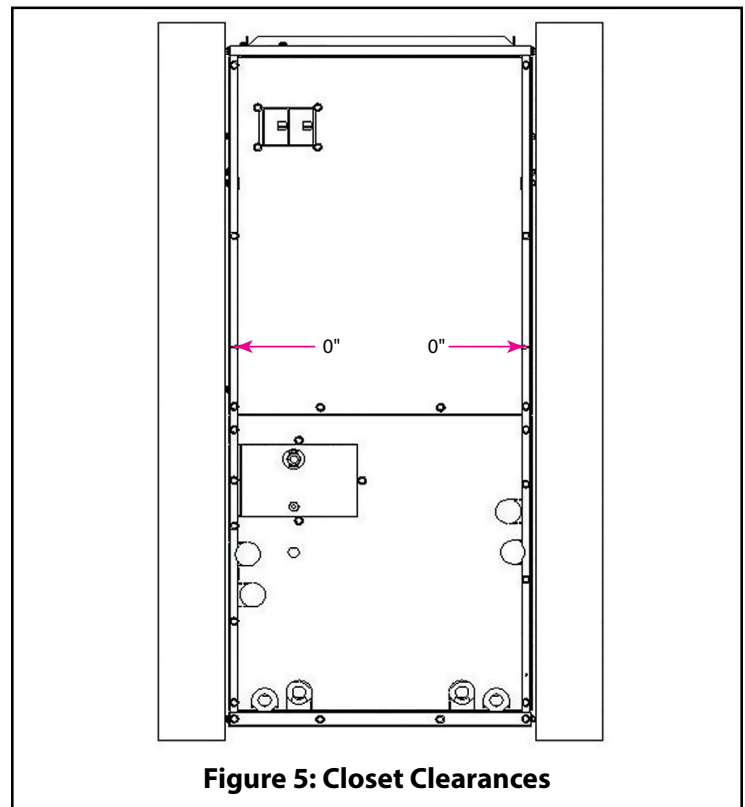

Figure 5: Closet Clearances

WARNING

RISK OF FIRE – FLAMMABLE REFRIGERANT APPLICATIONS

The following requirements are necessary to allow the flammable refrigerant mitigation system to properly dilute the refrigerant with air in the event of a refrigerant leak.

The supply and return air shall be directly ducted to the space. Open areas such as false ceilings shall not be used as a return air duct.

SECTION 4: AIR HANDLER ORIENTATION, RETURN AIR AND RETURN AIR FILTERS

The air handler is shipped from the factory configured to be installed in upflow air-flow applications. This air handler is field convertible to the downflow or horizontal air-flow positions using the procedures described in those sections below.

UPFLOW APPLICATIONS

In an upflow installation, the discharge outlet is at the top. Care should be taken to ensure air handler is level to permit proper condensate drainage. A typical upflow installation will be in a closet or basement. If installed in a closet, the closet should have a platform framed in that measures at least 12 inches in height with an opening cut in the top of the platform for the return air to enter the bottom of the air handler. A filter frame and filter can be used that covers the opening and is sealed to prevent air by-passing the filter. A filter grille can be used that is located as described in the **RETURN AIR AND AIR FILTER REQUIREMENTS** later in this section.

HORIZONTAL APPLICATIONS

Horizontal applications will normally be used in an attic or crawl space. This type of installation requires supply air plenum or duct to be connected to the supply collar and a return air plenum or duct be attached to the air handler inlet collar. The supply ducts will be connected to the supply air plenum and routed through the attic to a register in each room. Use a non-tape sealant such as mastic or an aerosol sealant to prevent leaks in the ducts and the plenum.

The MM Series air handlers are shipped to be installed without modifications for right-to-left or left-to-right supply air discharge applications. The MS Series air handlers require modifications for horizontal applications.

To convert the MS Series air handler for horizontal right-to-left air discharge applications:

1. Remove the air handler coil access panel.
2. Remove the cooling coil.
3. Reposition and caulk the coil top cap as shown in Figure 6.
4. Reinstall the cooling coil.
5. Connect the condensate drains and refrigerant lines.
6. Reinstall the coil access panel.

To convert the MS Series air handler for horizontal left-to-right air discharge applications:

1. Remove the air handler coil access panel.
2. Disconnect the wiring harness from the refrigerant leak sensor located on the front coil's delta plate and relocate the sensor to the opposite side of the delta plate as described in **SECTION 7: REFRIGERANT LEAK DETECTION SYSTEM OPERATION AND SENSOR INSTALLATION**.
3. Remove the cooling coil.
4. Reposition and caulk the coil top cap as shown in Figure 6.
5. Move the condensate drain pan to the right side.
6. Reinstall the cooling coil.
7. Reconnect the refrigerant leak sensor wiring harness to the refrigerant leak sensor.
8. Connect the condensate drains and refrigerant lines.
9. Reinstall the coil access panel.

TOP CAP POSITION AS SHIPPED FROM FACTORY FOR UPFLOW & DOWNFLOW APPLICATIONS

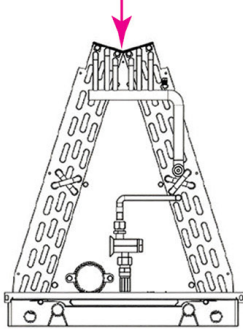

UPFLOW & DOWNFLOW APPLICATIONS

REPOSITION TOP CAP

CAULK WHERE TOP CAP MATES WITH COIL TUBE SHEETS ON BOTH SIDES

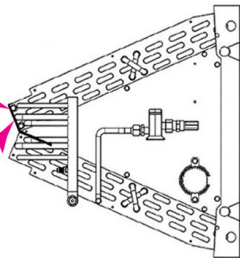

HORIZONTAL LEFT APPLICATIONS

REPOSITION TOP CAP

CAULK WHERE TOP CAP MATES WITH COIL TUBE SHEETS ON BOTH SIDES

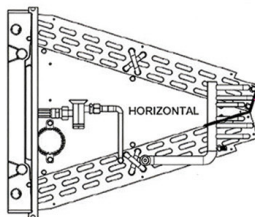

HORIZONTAL LEFT APPLICATIONS

Figure 6: Coil Top Cap Repositioning and Caulking for Horizontal Applications

An MM Series air handler may be installed in the downflow configuration by simply installing it with the supply air discharge pointing downward.

The MS Series air handlers may be converted to the downflow configuration using a required downflow conversion kit by following the instructions below (See Figures 7 and 8).

1. Remove the air handler coil access panel.
2. Remove indoor coil access panel and discard it. The indoor coil access panel will not be re-used.
3. Remove indoor coil assembly with drain pan by sliding out the front of the air handler as shown in Figure 7.
4. Remove 6 screws (3 on each side of air handler), securing indoor coil support rails. Refer to Figure 7.
5. Flip the air handler so the discharge is on the bottom.
6. Re-install the indoor coil support rails in the holes provided in the air handler casing as shown in Figure 8. Use the six (6) screws that were removed in step 4 to secure the indoor coil support rails to the air handler casing.
7. Re-install the cooling coil in the upright position as shown in Figure 8.
8. Remove the new indoor coil access panel from the conversion kit and install over the indoor coil section as shown in Figure 8.
9. Re-install the blower and control box access panel in the upside-down position and secure with the screws that were removed in step 1.

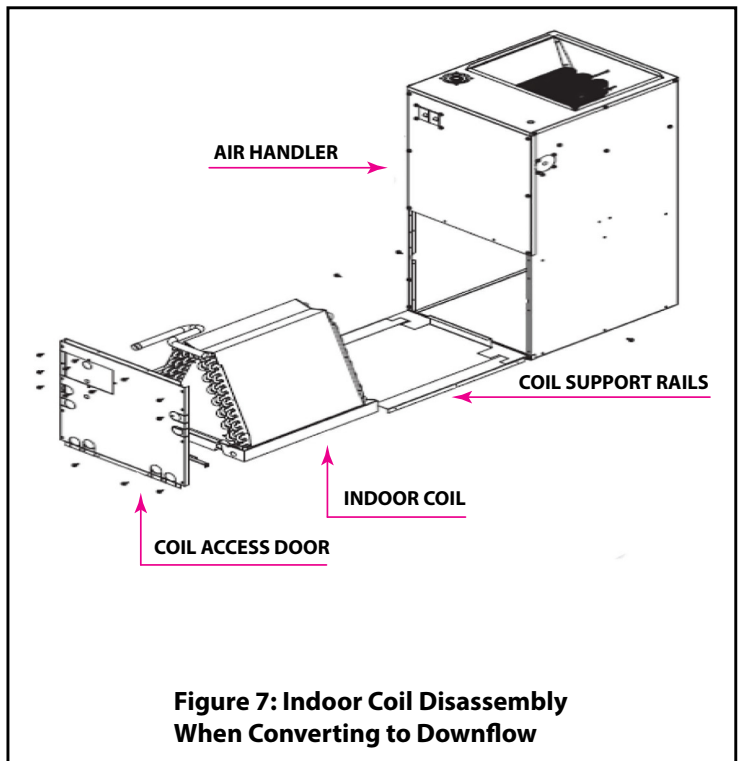

Figure 7: Indoor Coil Disassembly When Converting to Downflow

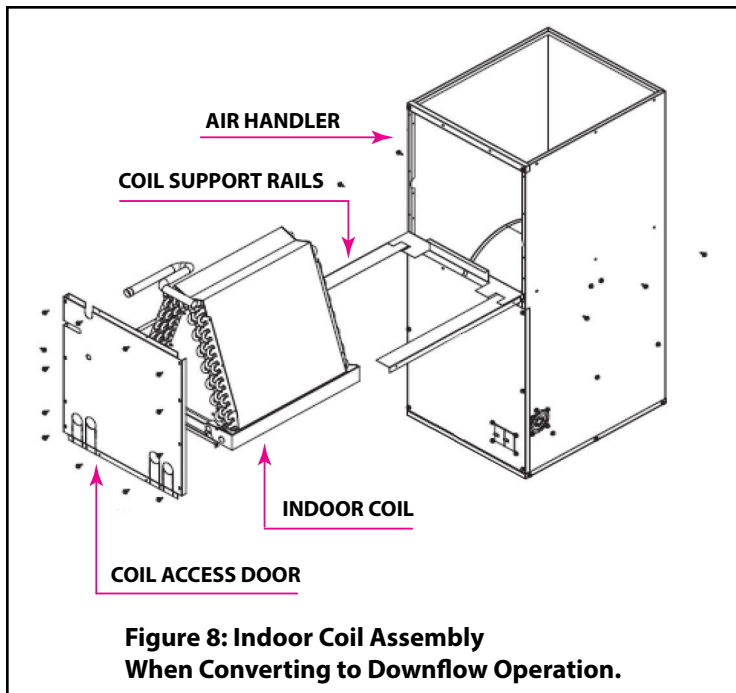

Figure 8: Indoor Coil Assembly When Converting to Downflow Operation.

COMBUSTIBLE FLOOR BASE FOR DOWNFLOW APPLICATIONS

It is required that the installer provide a combustibile floor base similar to what is shown in Figure 9 that is field supplied and installed on any combustibile flooring where the air handler is installed in downflow applications. The overall dimensions of the combustibile floor base must be the same as the air handler footprint shown in Figures 1-3 (dimensions A & C) and the opening on the floor and supply duct must be the same size as the supply opening in the air handler as shown in Figures 1-3 (dimensions D & E) to allow for proper airflow through the air handler.

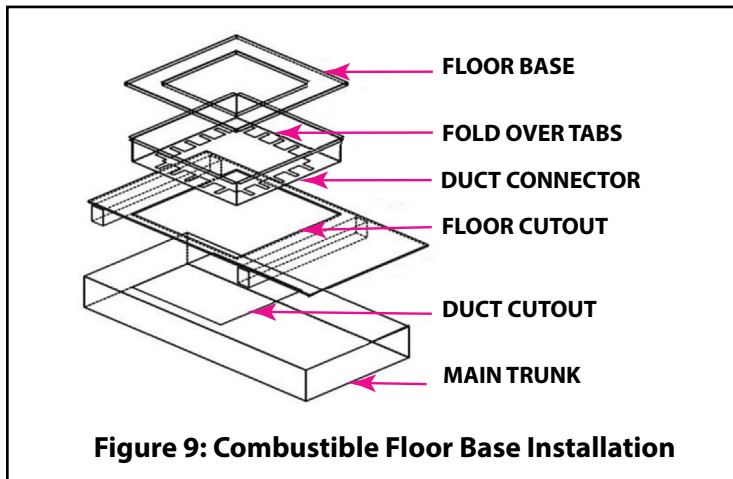

Figure 9: Combustible Floor Base Installation

RETURN AIR REQUIREMENTS

Provisions shall be made to permit the air in all rooms in the living space to return to the air handler. Failure to comply may cause a reduction in the amount of return air available to the blower, causing reduced airflow resulting in improper heating of the living space. The reduced airflow may cause the air handler to cycle on the electric heater's over-temperature limit causing premature heating element failure.

The return air opening can be located in the floor, on a closet front door, or in a side wall above the air handler cabinet. If the opening for the return air is located in the floor, side walls, or closet

door anywhere below the air handler cabinet, a 6-inch minimum clearance between the air handler and the wall or door must be provided on the side where the return is located to provide for proper airflow. The 6-inch minimum clearance is not required if there is a return grille installed above the air handler casing providing the grille has a sufficient return air opening.

For the air handler to work properly, a closet or alcove must have a certain total free area opening for the return air.

Air Handlers With 1/3 HP Blower Motor (M*V*18 & 24)

- Minimum 200 in² free area opening
- Use Return Grille or Coil Cabinet

Air Handlers With 1/2 HP Blower Motor (M*V*25, 30, & 36)

- Minimum 250 in² free area opening
- Use Return Grille, A/C Coil Cabinet, or any return grille with a minimum 250 in² free area opening.

Air Handlers With 3/4 HP Blower Motor (M*V*37, 42, 48, & 60)

- Minimum 390 in² free area opening
- Use Return Grille, or A/C Coil Cabinet, or any return grille with a minimum 390 in² free area opening.

Air Handlers With 1.0 HP Blower Motor (M*V*72)

- Minimum 430 in² free area opening
- Use Return Grille, or A/C Coil Cabinet, or any return grille with a minimum 430 in² free area opening.

The minimum filter size is shown as follows:

Standard Throw Away Air Filter @ 300 ft/min or Less

- 800 CFM = 20 x 20 x 1
- 1000 CFM = 20 x 25 x 1
- 1200 CFM = 20 x 30 x 1
- 1400 CFM = 25 x 30 x 1
- 1600 CFM = 25 x 30 x 1
- 1800 CFM = 30 x 30 x 1
- 2000 CFM = 30 x 40 x 1 or two 30 x 20 x 1
- 2400 CFM = 30 x 40 x 1 or two 30 x 20 x 1

Pleated Air Filter @ 500 ft/min or Less

- 800 CFM = 16 x 16 x 1
- 1000 CFM = 18 x 20 x 1
- 1400 CFM = 20 x 20 x 1
- 1200 CFM = 20 x 20 x 1
- 1600 CFM = 20 x 25 x 1
- 1800 CFM = 20 x 30 x 1 or two 20 x 15 x 1
- 2000 CFM = 20 x 30 x 1 or two 20 x 15 x 1
- 2400 CFM = 25 x 30 x 1 or two 14 x 30 x 1

Another option is to use a SunTherm Air Filter Base Accessory Kit which can be used on the return air end of the air handler when configured in the upflow position (See Figure 10). The filter base is placed over the return plenum in the floor and sealed to the plenum using sealant or caulking material and/or tape. The air handler is placed on top of the return filter base and the return opening sealed to prevent leaks.

FILTER BASE ASSEMBLY KIT – FIELD INSTALLED

- 86ET0002 – 16" X 20" X 2" Small Cabinet
- 86ET0001 and 20" X 20" X 2" Medium Cabinet
- 86ET0003 – 20" X 24" X 2" Large Cabinet

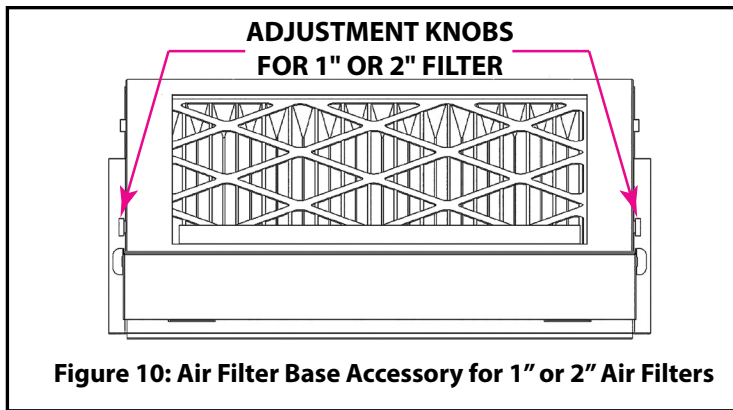

Figure 10: Air Filter Base Accessory for 1" or 2" Air Filters

Notes for Air Filter Base Accessory

- The filter size adjustment knobs are located on both sides of the base.
- Make sure the flow direction arrow on the air filter is pointing towards the coil.
- The Air Filter Base Accessory can also be used on the return air end of the air handler when configured in the downflow position in place of a wall, door or ceiling mounted return filter grille.

SECTION 5: INSTALLING THE AIR HANDLER

Prior to installing the air handler, make sure the holes are cut into the floor for the refrigerant tubing, the drain line, the electrical wiring, the thermostat wiring and the outdoor unit control wiring.

1. Remove the top shipping cover and corner posts.
2. Remove the bottom shipping cover.
3. Remove the blower and control box access panel.
4. Remove the coil compartment access panel.
5. Place the air handler into position using one of the following choices:
 - a) If the Combustible Floor Base is used, slide the air handler onto the combustible floor base until the air handler touching the flanges on the back of the floor base.
 - b) If the Combustible Floor Base is not used, slide the air handler over the duct opening until the opening in the air handler lines up with the duct opening in the floor.
6. Secure the air handler by one of the two choices:
 - a) If the Combustible Floor Base is used, secure the air handler to the floor by drilling two holes through the air handler cabinet base and the floor base at the right and left front inside corners of the cabinet. Use two screws to secure the air handler to the floor.
 - b) If the Combustible Floor Base is not used, secure the air handler to the floor by drilling two holes through the air handler base at the left and right front inside corners of the cabinet. Use two screws to secure the air handler to the floor.
7. Use caulking, sealers, and/or tape to seal between the combustible floor base and the opening on the air handler or between the opening on the air handler and the duct in the floor.
8. After the air handler has been secured to the return platform, connect the supply air outlet to a plenum to the top of the air handler and secure it with screws. Use a non-tape sealant such as mastic or an aerosol sealant to seal duct leakage. If the air handler is installed in a basement, run the supply and return duct work in accordance with local codes. Use a non-tape sealant such as mastic or an aerosol sealant to seal duct leakage.
9. Connect the electrical supply wires and the thermostat control wires in the control box.

10. Re-install the coil compartment access panel and secure with the screws that were removed in step 3.
11. Re-install the blower and control box access panel and secure with the screws that were removed in step 2.
12. Turn the power on to the air handler by following the procedure in the Users Information Manual.
13. Set the thermostat to the desired temperature.

SECTION 6: REFRIGERANT PIPING, TXV, AND CONDENSATE PIPING (MS SERIES ONLY)

Air handlers with DX type indoor coils require liquid and suction piping sized in accordance with outdoor unit manufacturer's instructions. Indoor coils have sweat copper connections. Refrigerant lines should be soldered with silver solder or high temperature brazing alloy. Suction line must be insulated to avoid condensate from forming and dropping off. Armaflex pipe insulation (or equivalent) with 3/8" (1 cm) minimum wall thickness is recommended. In severe conditions such as hot or high humidity areas require 1/2" (1.3 cm) minimum wall thickness may be required. If outdoor unit is installed above indoor coil, then oil traps are required at equal intervals along suction line (see Figure 11). Horizontal suction lines should slope downward 1 inch for every 20 feet toward outdoor unit. The manufacturer recommends that dry nitrogen be flowed through refrigerant lines during soldering operation.

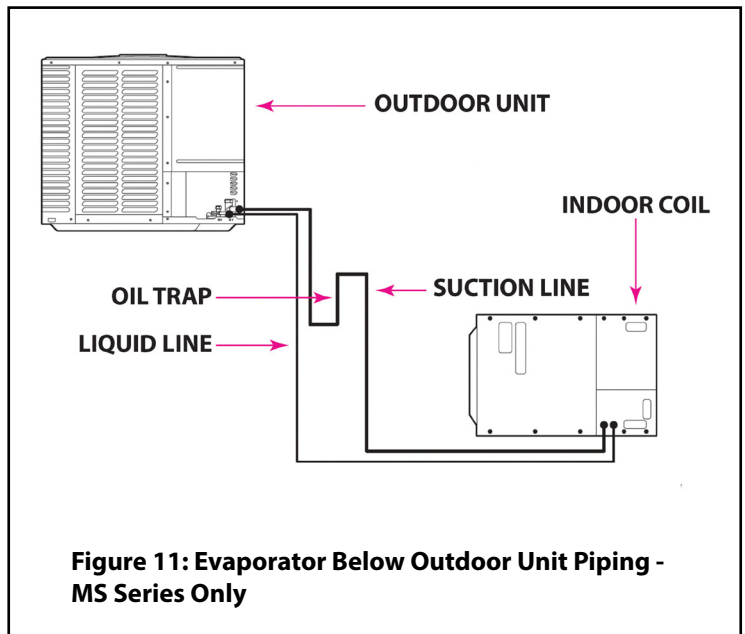

Figure 11: Evaporator Below Outdoor Unit Piping - MS Series Only

SPECIAL PIPING INSTRUCTIONS DUE TO THE USE OF AN A2L CLASS FLAMMABLE REFRIGERANT

! WARNING

This following precautions must be taken for the refrigerant piping due to this air-handler being used with an A2L class flammable refrigerant.

Piping material, pipe routing, and installation shall include protection from physical damage in operation and service, and shall be in compliance with national and local codes and standards, such as ASHRAE 15, IAPMO Uniform Mechanical Code,

ICC International Mechanical Code, or CSA B52. All field joints shall be accessible for inspection prior to being covered or enclosed.

The installation of pipe-work shall be kept to a minimum.

Due to this air-handler being used with an A2L class flammable refrigerant, the refrigerant pipe-work shall not be installed in an unventilated space if that space is smaller than the minimum floor area shown in Tables 22 and 23 unless there are no joints in the pipe-work in that space (e.g.: pipework that is run in walls or between floors).

Since refrigerant line length affects the final refrigerant charge, the final refrigerant charge after field charging of the system must be noted and used when determining the minimum floor area of the conditioned space from Tables 22 and 23.

Mechanical connections shall be accessible for maintenance purposes.

For appliances using flammable refrigerants, all joints made in the installation between parts of the refrigerating system with at least one part charged, shall be made in accordance with the following:

- A brazed, welded, or mechanical connection shall be made before opening the valves to permit refrigerant to flow between the refrigerating system parts. A vacuum valve shall be provided to evacuate the interconnecting pipe or any uncharged refrigerating part.
- Mechanical connectors used indoors shall comply with ISO 14903 or UL 207 Annex A (USA only). When mechanical connectors are reused indoors, sealing parts shall be renewed. When flared joints are reused indoors, the flare part shall be refabricated.
- Refrigerant tubing shall be protected or enclosed to avoid damage.
- Flexible refrigerant connectors (such as connecting lines between the indoor and outdoor unit) that may be displaced during normal operation shall be protected against mechanical damage.
- For installations with field applied joints that are exposed in the occupied space, these joints shall be at least one of the following:
 - mechanical joints in compliance with ISO 14903 or UL 207 or UL 207 Annex A (USA only).
 - welded or brazed joints; or
 - joints in enclosures that vent to the unit or to the outside.

Provision shall be made for expansion and contraction of long runs of piping.

Protection devices, piping, and fittings shall be protected as much as possible against adverse environmental effects (i.e.: water collecting and freezing in relief pipes or the accumulation of dirt and debris).

Piping in refrigeration systems shall be so designed and installed to minimize the likelihood of hydraulic shock damaging the system.

After completion of field piping for split systems, the field pipework shall be pressure tested with an inert gas and then vacuum tested prior to refrigerant charging, according to the following requirements:

- The minimum test pressure for the low side of the system shall be the low side design pressure as stated on the air handler rating plate and the minimum test pressure for the high side of the system shall be the high side design pressure as stated on

the air handler rating plate, unless the high side of the system cannot be isolated from the low side of the system in which case the entire system shall be pressure tested to the low side design pressure.

- The test pressure after removal of pressure source shall be maintained for at least 1 hour with no decrease of pressure indicated by the test gauge, with test gauge resolution not exceeding 5% of the test pressure.
- During the evacuation test, after achieving a vacuum level specified in the manual or less, the refrigeration system shall be isolated from the vacuum pump and the pressure shall not rise above 1500 microns within 10 min. The vacuum pressure level shall be the lesser of 500 microns or the value required for compliance with national and local codes and standards, which may vary between residential, commercial, and industrial buildings.

Field-made refrigerant joints indoors shall be tightness tested. The test method shall have a sensitivity of 5 grams per year of refrigerant or better under a pressure of at least 0.25 times the maximum allowable pressure. No leak shall be detected.

Thermal Expansion Valves (TXV) - MS Series Only

SunTherm air handlers can have a factory installed thermal expansion valve (TXV) or a TXV may be field installed. The factory and field installed TXV's for this air handler have an internal check valve making them compatible for both cooling only and heat pump applications. The TXV has an external pressure equalizer, non-adjustable superheat, and a 15% bleed rate. A hard start capacitor on the outdoor unit is normally not required when a 15% bleed TXV is used, but may be necessary if compressor starting issues are encountered.

A hard start capacitor on the outdoor unit is normally not required when a 15% bleed TXV is used, but may be necessary if compressor starting issues are encountered.

Field Installed TXV Kit Information:

R72DB0101DF: R-32, 1.5 – 3.0 Ton, 15% Bleed,
Inlet: Male Rotolock, Outlet: Female Swivel Nut

R72DB0102DF: R-32, 3.0 – 5.0 Ton, 15% Bleed,
Inlet: Male Rotolock, Outlet: Female Swivel Nut

R72DB0103DF: R-454B, 1.5 – 3.0 Ton, 15% Bleed,
Inlet: Male Rotolock, Outlet: Female Swivel Nut

R72DB0104DF: R-454B, 3.0 – 5.0 Ton, 15% Bleed,
Inlet: Male Rotolock, Outlet: Female Swivel Nut



Coil is pressurized with nitrogen from the factory. Relieve pressure before installing TXV by depressing the Schrader valve on the coil manifold.

Field Installed TXV Instructions

The TXV assembly is to be installed between the flowrator distributor and the existing liquid line attached to the flowrator distributor as shown in Figure 12.

1. After the coil pressure has been relieved, turn the female swivel nut counter-clockwise to remove.
2. Remove the piston from the flowrator distributor body using a small diameter wire or paper clip.

3. Attach the TXV by connecting the female swivel nut on TXV outlet to the flowrator distributor (aligning Teflon seal first) and torque swivel nut to 10-30 ft. lbs.
4. Attach liquid line with female swivel nut to male Rotolock fitting on TXV inlet (Aligning Teflon seal first) and torque swivel nut to 10-30 ft. lbs.
5. Remove the cap from the male Schrader valve port on the coil manifold. Attach equalizer tube with 1/4" female flare nut that includes a valve depressor to the male Schrader valve port. Torque the flare nut to 10-30 ft. lb.

Field and Factory Installed TXV Instructions – Sensing Bulb, Leak Check, Evacuation

1. Install the TXV bulb on the suction line just outside the air handler cabinet (See Figure 13) using the two bulb clamps furnished with kit.
2. The bulb should be installed on the upper portion of a horizontal section of the suction line between 10:00 o'clock and 2:00 o'clock as shown in Figure 14.
3. If the bulb must be installed on a vertical run, the bulb should be located at least 6 inches from any bend, and on the tubing side opposite the plane of the bend. On vertical bulb installations, the bulb should be positioned with the bulb capillary tube at the top. The bulb must be insulated using thermal insulation to protect it from the effect of the surrounding ambient temperature.
4. After completing the installation of the TXV (including equalizer tube), leak check the coil and evacuate the coil through the liquid and suction line valves on the outdoor unit.

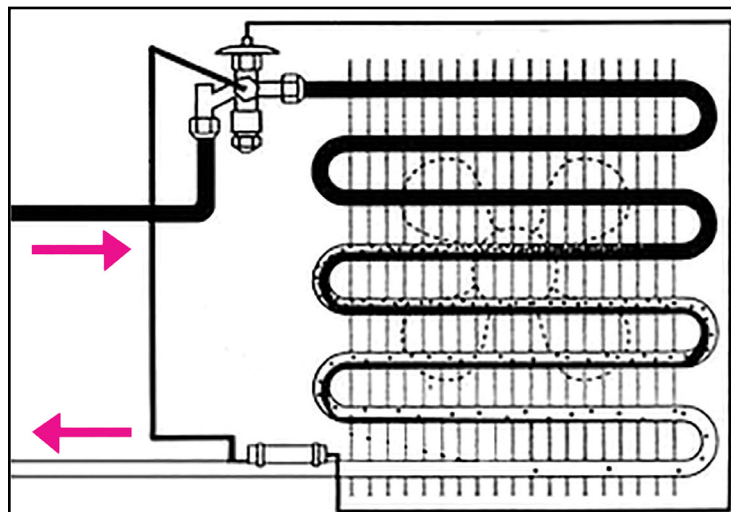

Figure 13: TXV Sensing Bulb Location

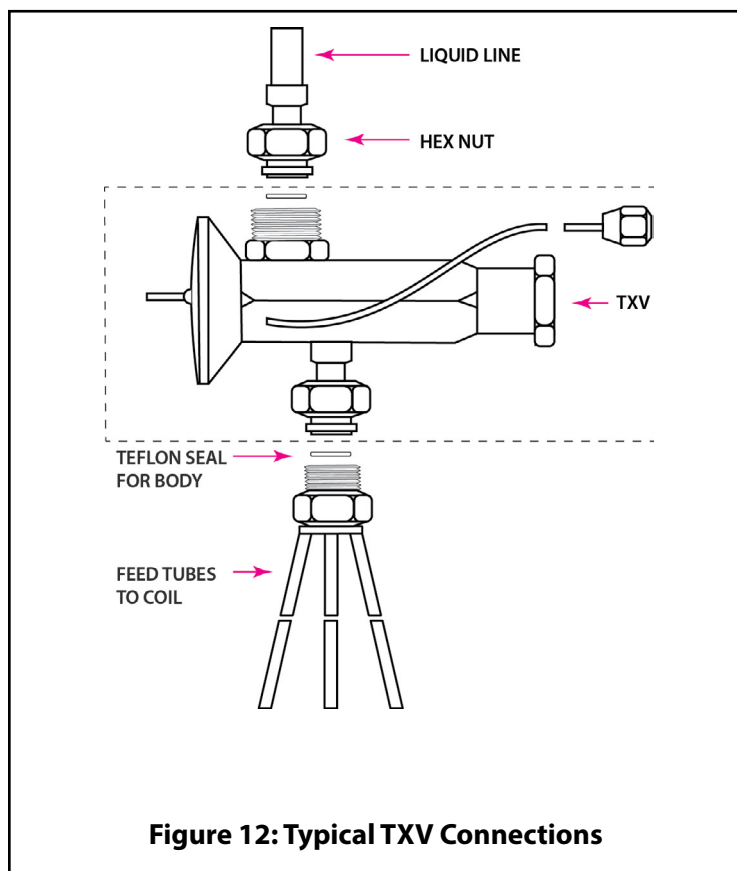
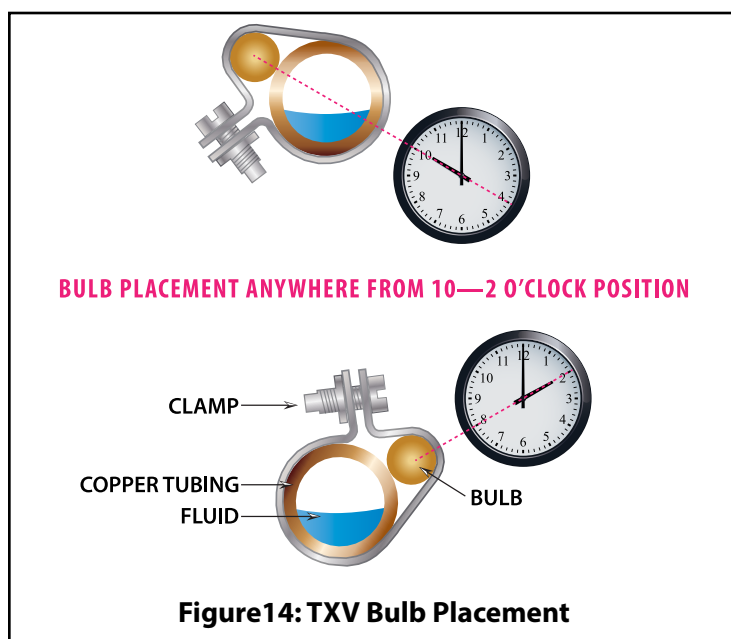

Figure 12: Typical TXV Connections



BULB PLACEMENT ANYWHERE FROM 10—2 O'CLOCK POSITION

Figure 14: TXV Bulb Placement

CONDENSATE DRAIN PIPING:

The air handler "A" coil drain pan has two 3/4" NPT female primary and two secondary connections (left or right hand). Piping from each fitting used is to have 2" minimum trap (See Figure 15) and each run in such a manner as to provide enough slope for adequate drainage to a visible area. Do not pipe these two fittings together into a common drain. If a secondary drain is not installed, the secondary drain connection must be capped.

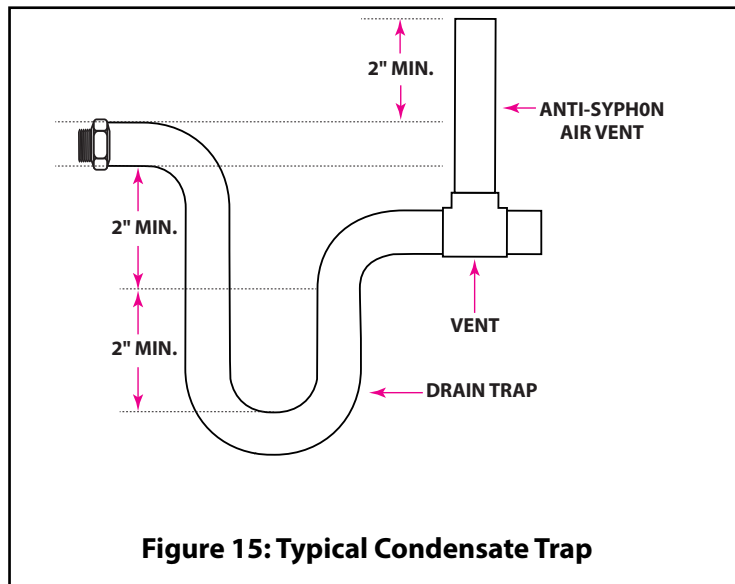

Figure 15: Typical Condensate Trap

WARNING

Air handler must be located so that if any connections should leak, water will not cause damage to the adjacent area. When such locations can't be avoided, a suitable drain pan should be installed under the air handler, not over 1 1/2" deep, with minimum length and width at least 2" greater than the air handler dimensions and connected to an adequate drain. Under no circumstances is the manufacturer to be held liable for any water damage in connection with this air handler.

WARNING

This air handler is equipped with a refrigerant leak mitigation system that energizes the air handler blower motor to deliver at least the required minimum airflow (See Table 22 or 23) when the refrigerant leak detection system detects a leak. This will dilute the flammable A2L class refrigerant to a point that it no longer poses a risk of an explosion or fire. Follow the procedure "Verifying Proper Functioning of Refrigerant Leak Mitigation System" later in this section to confirm the refrigerant mitigation system is functioning as it should.

WARNING

Minimum Allowable Operating Temperatures
Water/Brine: Water = 36°F (2.22°C)
Brine Solution = 3.2°F (-16°C)

CHILLED WATER PIPING

All water pipes must be supported independent of coils to prevent vibration and stress on coil headers. Swing joints or flexible fittings must be provided to absorb expansion and contraction strains. Rigid piping reduces the effectiveness of vibration isolators. Coil water pipes must be adequately vented in order to prevent air binding. Air handlers are provided with manual air vents mounted through the manifold panel.

Supply and return chilled water piping to the coil should be 3/4" ID up to 42,000 BTU/Hr, 1" on air handlers greater than 42,000 BTU/Hr. Water piping must always be connected so that the entering water is on the leaving air side of the coil.

SECTION 7: REFRIGERANT LEAK DETECTION SYSTEM OPERATION AND SENSOR INSTALLATION

This air handler is equipped with a factory installed refrigerant leak detection system consisting of a refrigerant sensor with integral relays to perform the necessary leak mitigation if a refrigerant leak is detected by the sensor. Should a refrigerant leak occur in the indoor coil, the refrigerant leak detection system will energize the indoor blower and will open the 24VAC circuit to the outdoor unit compressor contactor. The circulation of air will disperse the leaked flammable refrigerant into the conditioned space where it will be diluted to point where it can no longer be ignited by an ignition source. The indoor blower will continue to operate until 5 minutes after the concentration of the refrigerant at the sensor drops below the sensor's setpoint. Should the concentration of the refrigerant rise above the setpoint of the sensor, the mitigation cycle will repeat until the refrigerant concentration stays below the setpoint of the sensor. The ORANGE sensor pigtail marked "ALARM" will normally be energized with 24VAC when no leak is detected and will be de-energized when a leak is detected for the purpose of notifying a building management system to issue a refrigerant leak alarm or to energize a leak warning light or audible alarm if a field supplied normally closed relay is installed (see Figure 17).

Should the sensor fail or if the sensor wiring is damaged or disconnected, the sensor will automatically enter the mitigation mode until the sensor is replaced or the wiring is reconnected or repaired.

IMPORTANT: The outdoor unit control wiring must be connected to the WHITE refrigerant sensor pigtail labeled "Y-CC" and the "COM" on the air handler low voltage terminal strip for the refrigerant detection system to de-energize the compressor during the leak mitigation mode of operation.

IMPORTANT: Only refrigerant detection system sensors specified by Mortex Products, Inc. may be used as a replacement for a failed sensor.

Relocating Refrigerant Sensor for Horizontal Right Discharge Applications

The refrigerant sensor is factory installed in the correct location for upflow, downflow, and horizontal left discharge applications only. For horizontal right applications, the sensor must be moved to the opposite side of the coil delta plate as shown in Figure 16. Mounting holes are provided on the opposite side of the coil delta plate for mounting the sensor for horizontal right discharge applications as shown in Figure 16. Remove the 2 screws securing the sensor to the coil delta plate. Attach the sensor with the same two screws to the holes in the opposite side of the coil delta plate.

IMPORTANT: The refrigerant detection system sensor wiring harness plug must be pointing down or horizontal. If the plug is pointing up, water could collect in the plug and result in operational issues. This does not apply to Cubic brand sensors which have a water tight plug and will be pointing up in horizontal applications.

UPFLOW AND DOWNFLOW APPLICATIONS

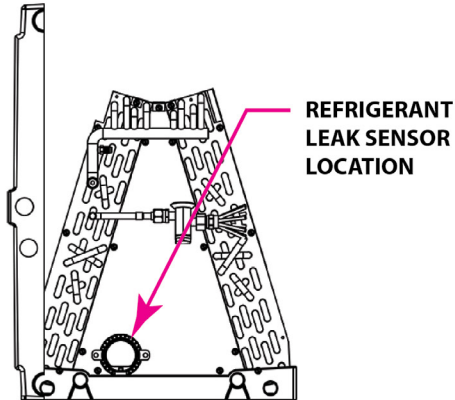

HORIZONTAL LEFT DISCHARGE APPLICATIONS

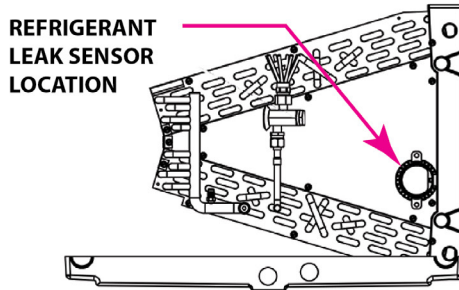

HORIZONTAL RIGHT DISCHARGE APPLICATIONS

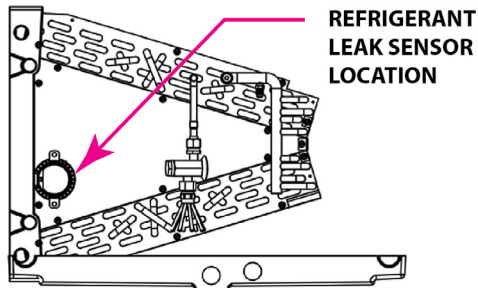

Figure 16: Refrigerant Leak Detection Sensor Location

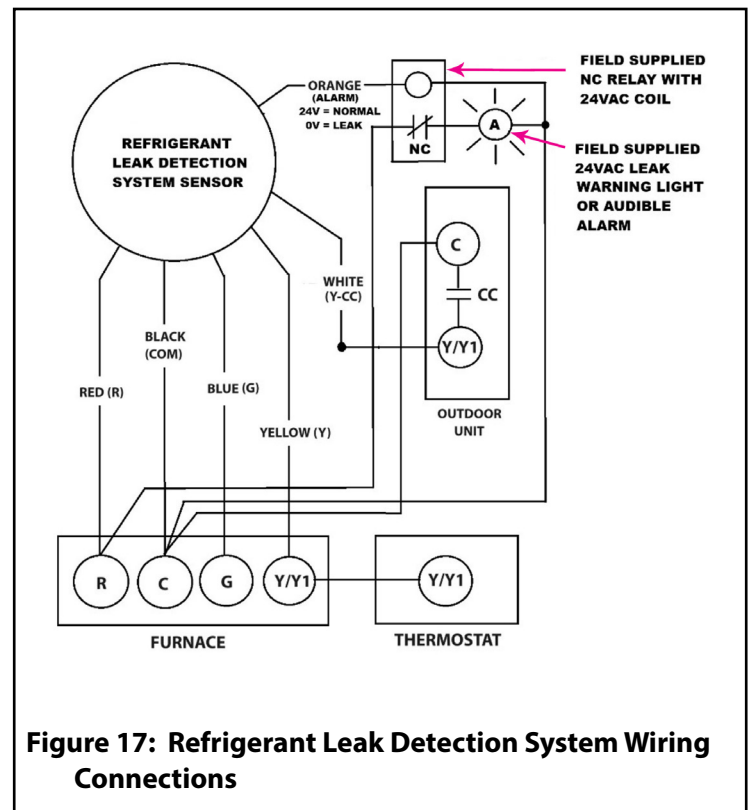

Figure 17: Refrigerant Leak Detection System Wiring Connections

Verifying Proper Functioning of Refrigerant Leak Mitigation System

Follow the steps below to verify the proper functioning of the Refrigerant Leak Mitigation System.

1. Remove the coil access panel from the front of the air handler.
2. Locate the black refrigerant sensor located near the bottom front of the coil assembly.

Leak Detected During Cooling Cycle

3. Set the thermostat to "COOL" and the fan switch to "AUTO" and lower the temperature setpoint below the indoor temperature so the system enters the cooling mode.
4. Confirm the outdoor unit compressor is operating.
5. Within 30 seconds of the compressor starting, release a small amount of refrigerant on the refrigerant sensor to activate the leak mitigation mode.
6. Confirm the outdoor unit compressor and fan motor shut down and the indoor blower continues to operate.
7. Confirm the indoor blower is energized and 24V is not present at the ORANGE air handler pigtail marked "ALARM".
8. Confirm the outdoor unit compressor and fan motor are re-energized approximately 5 minutes after the flow of refrigerant near the sensor has ended and that the indoor blower continues to operate.

Leak Detected During the OFF Cycle

9. Set the thermostat to the "OFF" position and wait until the outdoor unit compressor and fan motor stop and indoor blower stops.
10. Release a small amount of refrigerant on the refrigerant sensor to activate the leak mitigation mode.
11. Confirm the indoor blower is energized and 24V is not present at the ORANGE air handler pigtail marked "ALARM".
12. Confirm the indoor blower shuts down after approximately 5 minutes after the flow of refrigerant on the refrigerant sensor has ended.

13. If the Refrigerant Leak Mitigation System does not operate as stated above, check for loose wiring connections or replace the refrigerant sensor.

14. Reinstall the coil access panel on the air handler.

15. Set the thermostat to the desired operating mode and temperature.

If the leak detection system does not function properly when subjected to the above procedure, check for miswiring of the system. If the wiring connections are found to be correct per the air handler wiring diagram, replace the sensor with an approved replacement from the manufacturer.

Leak Detection Sensor Replacement

When the refrigerant leak detection system sensor fails or reaches the end of its life, the leak detection system will enter and remain in the leak mitigation mode even though there is no refrigerant leak present. If the leak detection system continues to operate in the mitigation mode even when a refrigerant leak isn't indicated by a portable refrigerant leak detector, replace the sensor with an approved replacement from the air handler manufacturer. Disconnect the wiring harness connector from the failed sensor and remove the sensor mounting screws. Discard the failed sensor. Mount the replacement sensor in the same location as the failed sensor that was removed and connect the sensor wiring harness connector to the sensor.

IMPORTANT: Mortex may source sensors from various manufacturers that have a different wiring harness connection. A wiring may be necessary to allow the replacement sensor to connect the sensor wiring harness. The wiring adapter will be provided with the replacement sensor. Alternate mounting holes are provided in the coil delta plate to accommodate the various approved sensors. Only use a replacement sensor approved by and provided by Mortex to assure proper operation and compatibility.

Minimum Circulating Airflow for Refrigerant Leak Mitigation

There is a minimum circulating airflow required when the refrigerant leak detection system is operating in the leak mitigation mode. This minimum depends on the total system refrigerant charge and can be found listed in Tables 22 and 23. The refrigerant mitigation system energizes the continuous fan speed on the air handler. The continuous fan CFM (l/s) may need to be increased to achieve the minimum leak mitigation circulating airflow level by changing to a different indoor blower motor speed tap or ECM motor setting that delivers the minimum mitigation airflow level. Refer to the blower performance tables and wiring diagrams in this manual to determine if this adjustment is necessary and if it is determined to be necessary to increase the continuous fan airflow level, follow the instructions in **SECTION 12: MOTOR SPEED SELECTION AND AIR HANDLER STARTUP** in this manual to make the necessary adjustment.

Refrigerant Leak Alarm Output

The coil's refrigerant leak sensor has an alarm output signal that can be used as an input to a building management system or smart thermostat to alert the homeowner or user that the refrigerant detection system has detected a refrigerant leak and is in the leak mitigation mode. There is an ORANGE low voltage pigtail wire in the sensor harness labeled "ALARM". When the sensor is powered and no refrigerant leak is detected, the ORANGE "ALARM" pigtail wire is energized with 24 VAC indicating normal operation. When the refrigerant leak detection system detects a refrigerant leak and enters the leak mitigation mode (indoor blower energized and

outdoor unit disabled), the ORANGE "ALARM" pigtail wire will be de-energized (0 VAC). The ORANGE "ALARM" pigtail wire is capped with a wire nut from the factory. Remove this wire nut and connect it to the building management system or smart thermostat as required if a refrigerant leak alert is desired. The building management system or smart thermostat shall be programmed to accept the reverse logic alarm signal (24 VAC – Normal; 0 VAC – Refrigerant Leak).

If a 24 VAC output when a refrigerant leak is detected is required to activate a warning light or audible alarm, the ORANGE "ALARM" pigtail wire shall be connected to the coil of a field supplied relay with normally closed contacts and a 24 VAC coil. An 18 AWG minimum wire from the furnace 24 VAC common circuit shall be connected to the other side of the relay coil. An 18 AWG minimum wire from the furnace 24 VAC "R" transformer circuit shall be connected to the terminal for one side of the normally closed relay contacts and an 18 AWG minimum wire to the warning light or audible alarm shall be connected to terminal for the other side of the normally closed relay contacts. All field supplied wiring shall be protected from damage. When no refrigerant leak is detected, the relay will be energized and the relay contacts will be open, disconnecting the 24 VAC signal to the warning light or audible alarm. When a refrigerant leak is detected, the relay will be de-energized and the contacts will close sending a 24 VAC signal to the warning light or audible alarm. See Figure 17 for suggested field wiring connections.

The unit internal wiring is complete except for the power supply and the thermostat wires. See wiring diagram and/or Tables 8-11 for wire size, fuse/circuit breaker size, and ground wire sizes. The use of cable connectors on incoming power supply wires to relieve any strain on wiring is recommended. Follow the steps below to connect the power supply wires.

NOTE: A means of disconnecting all poles of the line voltage power to the air handler must be provided in the field wiring within sight of the air handler unless the air handler is equipped with integral circuit breaker(s) with their ON/OFF lever(s) located on the outside of the air handler which can be used to disconnect line voltage electrical power to the air handler.

NOTE: This air handler is shipped from the factory for 240VAC applications. The transformer must be reconfigured for 208VAC applications using the following steps to assure adequate control voltage (24VAC).

1. Remove the zip tie from the transformer wire bundle that secures the BLACK, ORANGE and WHITE wires together.
2. Disconnect the WHITE (240VAC) transformer primary wire with an insulated terminal from the load side of the circuit breaker and connect the ORANGE (208VAC) transformer primary wire with an insulated terminal to the same terminal on the circuit breaker.
3. Secure the loose BLACK, ORANGE and WHITE wires to the transformer wire bundle with a zip tie.

Single Circuit Line Voltage Wiring Connections

1. Remove the blower and control box access panel.
2. Remove the control box cover.
3. Remove the appropriate size slug from the line voltage wiring entrance knockout on the left side or top of the air handler cabinet and install a strain relief bushing that will accommodate all of the power supply wires in the hole.
4. Strip 1/2" of the insulation on the end of each wire.
5. Insert the wires through the holes in the air handler casing and through the strain relief bushing.
6. Insert the BLACK wire into the L1 screw terminal on the first circuit breaker from the top and tighten the set screw on the wire.
7. Insert the WHITE or RED wire into the L2 screw terminal on the first circuit breaker down from the top and tighten the set screw on the wire.
8. If a single circuit is being used for a 5 kW, 10kW, 15kW or 20kW model, install a BLACK jumper wire from the L1 terminal on circuit breaker #1 to the L1 terminal on circuit breaker #2 and a WHITE or RED jumper wire from the L2 terminal on circuit breaker #1 to the L2 terminal on circuit breaker #2. Refer to Figures 18, 20, and 21 for circuit breaker locations.
9. Insert the GREEN ground wire into the ground lug and tighten the set screw on the wire.
10. Tighten the screw on the strain relief bushing until the power supply wires are securely held by the bushing.

NOTE: The 100 amp 4-Pole Jumper Bar Assembly part number 68BAE001 can be used in place of the jumper wires.

Dual Circuit Line Voltage Wiring Connections: 15kW or 20kW Models

1. Follow steps 1 - 7 in Single Circuit Line Voltage Connections above.
2. Insert the BLACK wire from the second power supply into the L1 screw terminal on the second circuit breaker down from the top and tighten the set screw on the wire.
3. Insert the WHITE or RED wire from the second power supply into the L2 screw terminal on the second circuit breaker down from the top and tighten the set screw on the wire.
4. Insert the GREEN ground wires for both circuits into the ground lugs and tighten the set screws on the wires.
5. Tighten the screw on the strain relief bushing until the power supply wires are securely held by the bushing.

NOTE: The air handler is equipped with either one or two circuit breakers. These circuit breakers protect the wiring inside of the air handler in the event of a short circuit. Additionally, these breakers provide a means of disconnecting the power to the air handler. The circuit breakers in the air handler are not meant to protect the branch circuit wiring between the air handler and the home's breaker panel. General wire and breaker sizes are shown in Tables 8-11. If sheathed cable is used, refer to NEC National Electrical Code (NFPA 70) or the Canadian Electrical Code, Part I (CSA C22.1) and local codes for additional requirements concerning supply circuit wiring. Electrical data can be found in Tables 8-11.

IMPORTANT - All field wiring must be rated at 60°C or higher. Please refer to the wiring diagrams on the air handler or the tables in this manual for more information. The 15kW and 20kW models may be connected to a single or dual branch circuit.

AIR HANDLER MODELS														
	M*VE 18, 24			M*VT 18, 24			M*VE 25, 30, 36				M*VT 25, 30, 36			
5 kW Heater Amps - 208/240 VAC	18.0/20.8			18.0/20.8			18.0/20.8				18.0/20.8			
10 kW Heater Amps - 208/240 VAC	36.1/41.7			36.1/41.7			36.1/41.7				36.1/41.7			
15 kW Heater Amps - 208/240 VAC	N/A			N/A			54.1/62.5				54.1/62.5			
Indoor Blower Motor Type	ECM			CONSTANT TORQUE			ECM				CONSTANT TORQUE			
Indoor Blower Amps – 208/240 VAC	3.81/4.40			2.43/2.80			4.33/5.00				3.55/4.10			
Heater - kW	0	5	10	0	5	10	0	5	10	15	0	5	10	15
Minimum Circuit Ampacity	5.50	31.54	56.48	3.50	29.54	55.58	6.25	32.29	58.33	84.37	5.13	31.17	57.21	83.25
Min. Wire Size (90°C)	#14	#12	#8	#14	#12	#8	#14	#12	#8	#4	#14	#12	#8	#4
Minimum Wire Size (75°C)	#14	#10	#6	#14	#10	#6	#14	#10	#6	#4	#14	#10	#6	#4
Minimum Wire Size (60°C)	#14	#10	#6	#14	#10	#6	#14	#10	#6	#3	#14	#10	#6	#3
Ground Wire Size	*	*	*	*	*	*	*	*	*	*	*	*	*	*
Maximum Overcurrent Protection Amps**	15	35	60	15	30	60	15	35	60	90	15	35	60	90

Table 8: Electrical Data: 18-36 kBTU Models - Single Branch Circuit

15kW and 20 kW models may have a dual or single power supply. Single power supply requires a jumper bar or a jumper wire.
+ Refer to the National Electrical Code Table 250-95 for Non-Sheathed Conductor Ground Wire.

* Ground conductor must be the same size and temperature rating as the other conductors listed in Table 8.

** Circuit breakers must be HACR type.

AIR HANDLER MODELS																				
	M*VE 37, 42, 48, 60					M*VT 37, 42, 48, 60					M*VE 72					M*VT 72				
5 kW Heater Amps - 208/240 VAC	18.0/20.8					18.0/20.8					18.0/20.8					18.0/20.8				
10 kW Heater Amps - 208/240 VAC	36.1/41.7					36.1/41.7					36.1/41.7					36.1/41.7				
15 kW Heater Amps - 208/240 VAC	54.1/62.5					54.1/62.5					54.1/62.5					54.1/62.5				
20 kW Heater Amps - 208/240 VAC	72.2/83.4					72.2/83.4					72.2/83.4					72.2/83.4				
Indoor Blower Motor Type	ECM					CONSTANT TORQUE					ECM					CONSTANT TORQUE				
Indoor Blower Amps – 208/240 VAC	5.46/6.30					5.37/6.20					5.98/6.32					5.46/6.30				
Heater - kW	0	5	10	15	20	0	5	10	15	20	0	5	10	15	20	0	5	10	15	20
Minimum Circuit Ampacity	7.88	33.92	59.96	86.00	112.04	7.75	33.79	59.83	85.67	111.91	7.90	33.94	59.98	86.02	112.06	7.88	33.92	59.96	86.00	112.04
Min. Wire Size (90°C)	#14	#12	#6	#4	#3	#14	#12	#6	#4	#3	#14	#10	#6	#4	#3	#14	#10	#6	#4	#2
Minimum Wire Size (75°C)	#14	#10	#6	#4	#2	#14	#10	#6	#4	#2	#14	#10	#6	#4	#2	#14	#10	#6	#3	#2
Minimum Wire Size (60°C)	#14	#10	#4	#3	#1	#14	#10	#4	#3	#1	#14	#8	#4	#3	#1	#14	#8	#4	#2	#1
Ground Wire Size	*	*	*	*	*	*	*	*	*	*	*	*	*	*	*	*	*	*	*	*
Maximum Overcurrent Protection Amps**	15	35	60	90	120	15	35	60	90	120	15	35	60	90	110	15	35	60	90	120

Table 9: Electrical Data: 37-72 kBTU Models - Single Branch Circuit

15kW and 20kW models may have a dual or single power supply. Single power supply requires a jumper bar or a jumper wire.
+ Refer to the National Electrical Code Table 250-95 for Non-Sheathed Conductor Ground Wire.

* Ground conductor must be the same size and temperature rating as the other conductors listed in Table 9.

** Circuit breakers must be HACR type.

AIR HANDLER MODELS				
	M*VE 25, 30, 36		M*VT 25, 30, 36	
Circuit Number	1	2	1	2
15 kW Heater Amps - 208/240 VAC	36.1/41.7	18.0/20.8	36.1/41.7	18.0/20.8
Indoor Blower Motor Type	ECM		CONSTANT TORQUE	
Indoor Blower Amps	4.33/5.00		3.55/4.10	
Heater - kW	15		15	
Circuit Number	1 (10kW)	2 (5kW)	1 (10kW)	2 (5kW)
Minimum Circuit Ampacity	58.33	32.29	57.21	31.17
Minimum Wire Size (90°C)	#8	#12	#8	#12
Minimum Wire Size (75°C)	#6	#10	#6	#10
Minimum Wire Size (60°C)	#6	#10	#6	#10
Ground Wire Size	*	*	*	*
Maximum Overcurrent Protection Amps **	60	35	60	35

Table 10: Electrical Data: 25-36 kBTU Models – Dual Branch Circuit

+ Refer to the National Electrical Code Table 250-95 for Non-Sheathed Conductor Ground Wire.

* Ground conductor must be the same size and temperature rating as the other conductors listed in Table 10.

** Circuit breakers must be HACR type.

AIR HANDLER MODELS																
	M*VE 37, 42, 48, 60				M*VT 37, 42, 48, 60				M*VE 72				M*VT 72			
Circuit Number	1		2		1		2		1		2		1		2	
15 kW Heater Amps - 208/240 VAC	36.1/41.7		18.0/20.8		36.1/41.7		18.0/20.8		36.1/41.7		18.0/20.8		36.1/41.7		18.0/20.8	
20 kW Heater Amps - 208/240 VAC	36.1/41.7		36.1/41.7		36.1/41.7		36.1/41.7		36.1/41.7		36.1/41.7		36.1/41.7		36.1/41.7	
Indoor Blower Motor Type	ECM				CONSTANT TORQUE				ECM				CONSTANT TORQUE			
Indoor Blower Amps	5.46/6.30				5.37/6.20				5.48/6.32				5.46/6.30			
Heater - kW	15		20		15		20		15		20		15		20	
Circuit Number	1 (10kW)	2 (5kW)	1 (10kW)	2 (10kW)	1 (10kW)	2 (5kW)	1 (10kW)	2 (10kW)	1 (10kW)	2 (5kW)	1 (10kW)	2 (10kW)	1 (10kW)	2 (5kW)	1 (10kW)	2 (10kW)
Minimum Circuit Ampacity	59.96	26.04	59.96	52.08	59.83	26.04	59.83	52.08	59.98	26.04	59.98	52.08	59.96	26.04	59.96	52.08
Minimum Wire Size (90°C)	#8	#12	#8	#8	#8	#12	#8	#8	#8	#12	#8	#8	#8	#12	#6	#8
Minimum Wire Size (75°C)	#6	#10	#6	#6	#6	#10	#6	#6	#6	#10	#6	#6	#6	#10	#6	#6
Minimum Wire Size (60°C)	#6	#10	#6	#6	#6	#10	#6	#6	#6	#10	#6	#6	#6	#10	#4	#6
Ground Wire Size	*	*	*	*	*	*	*	*	*	*	*	*	*	*	*	*
Maximum Overcurrent Protection Amps **	60	30	60	60	60	30	60	60	60	30	60	60	60	30	60	60

Table 11: Electrical Data: 37-72 kBTU Models – Dual Branch Circuit

+ Refer to the National Electrical Code Table 250-95 for Non-Sheathed Conductor Ground Wire.

* Ground conductor must be the same size and temperature rating as the other conductors listed in Table 11.

** Circuit breakers must be HACR type.

	ELECTRIC HEATER HEATING CAPACITIES						
	BRANCH CIRCUIT	5 kW	10 kW	15kW		20kW	
		1	1	1	2	1	2
240 VAC	BTU/HR	17,033	34,067	34,067	17,033	34,067	34,067
	kW	4.99	10.00	10.00	4.99	10.00	10.00
230 VAC	BTU/HR	15,876	33,686	33,686	15,876	33,686	33,686
	kW	4.65	9.78	9.78	4.65	9.78	9.78
220 VAC	BTU/HR	14,736	30,222	30,222	14,736	30,222	30,222
	kW	4.32	8.86	8.86	4.32	8.86	8.86
TOTAL HEATING CAPACITY @ 240 VAC	BTU/HR	17,033	34,067	51,149		68,134	
	kW	4.99	10.00	14.99		20.00	

Table 12: Electric Heater Heating Capacities

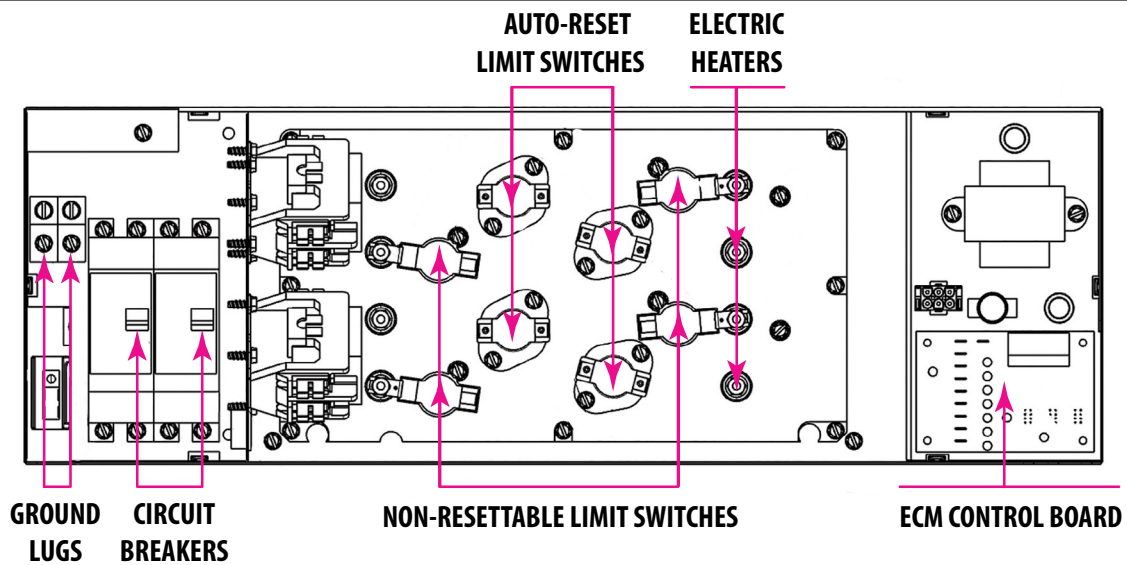

Figure 18: Component Locations – Electric Heat Control Box

NOTE: Casing or cabinet must be permanently grounded in accordance with the National Electrical Code or other applicable codes.

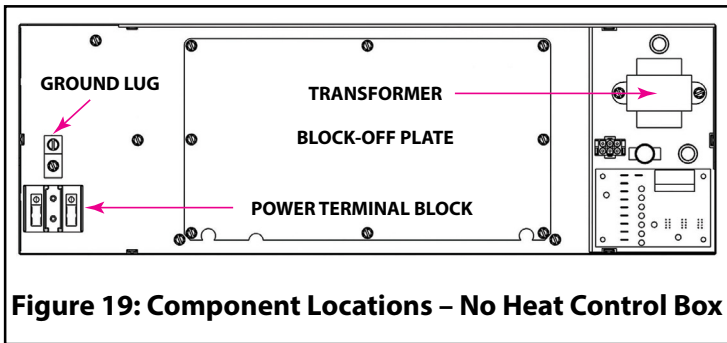

Figure 19: Component Locations – No Heat Control Box

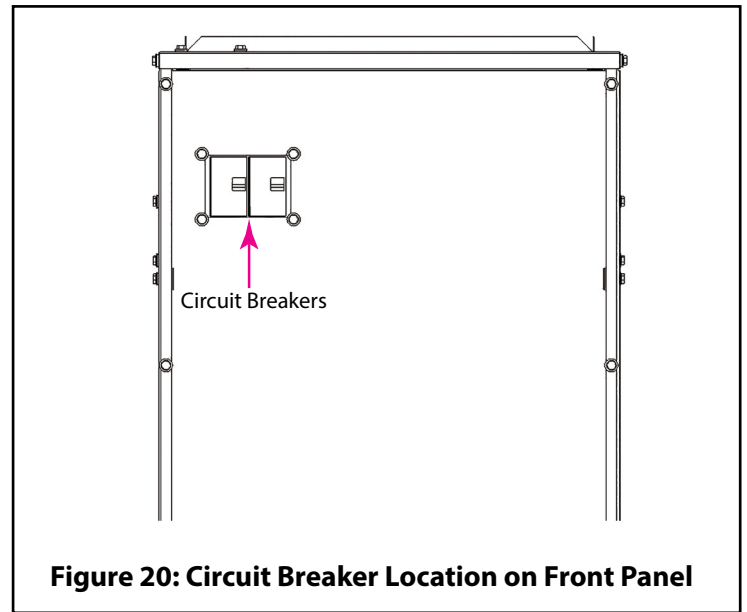

Figure 20: Circuit Breaker Location on Front Panel

WARNING

For personal safety be sure to turn the electrical power "OFF" at the main electrical panel and at the air handler control box circuit breakers before attempting any service or maintenance operations.

Homeowners and/or users should never attempt to perform any maintenance which requires opening the air handler control box cover.

WARNING

This air handler is not equipped with a shield that covers the line voltage electrical supply wires and the circuit breaker connections. Take precautions to prevent accidental electrical shock. Be sure to turn the electrical power "OFF" at the main electrical panel and at the air handler control box circuit breakers before removing the front panel. Refer to Figure 18 for the circuit breaker location on the front panel.

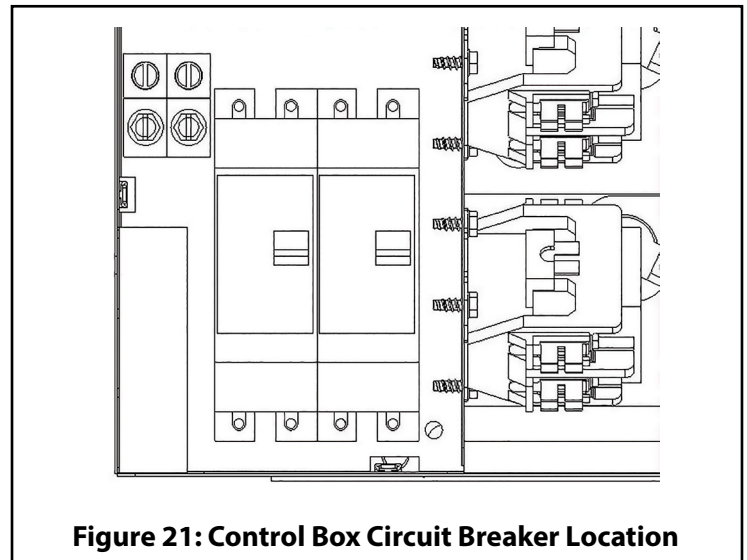

Figure 21: Control Box Circuit Breaker Location

SECTION 9: FIELD INSTALLED ELECTRIC HEATER KITS

The field installed electric heat accessories are used on air handlers that were not purchased with electric heat from the factory. Each air handler model is approved for use with the field installed accessory electric heat kit.

INSTALLING THE HEATERS

1. Follow the instructions in the **USERS INFORMATION MANUAL** to properly shut down the air handler.
2. Remove the block-off plate shown in Figure 19 and discard. Retain the screws, they will be used to secure the electric heater mount plate.
3. Remove the transformer wires and blower motor wires from the power terminal block and remove the power terminal block (See Figure 19).
4. Insert electric heater kit assembly into the opening where the block-off plate was removed. Secure the mounting plate with the screws that were removed from the block-off plate.
5. Connect the six-pin male plug on the electric heater assembly to the six-pin female plug mounted on the side of the low voltage control box divider panel.
6. Connect the transformer and blower motor wires to the L1 and L2 terminals on the load side of Circuit Breaker 1.
7. Remove the wiring diagram from the kit, remove the paper that covers the adhesive back and place the electric heat wiring diagram over the wiring diagram located on the blower housing.
8. Follow the instructions in the **USERS INFORMATION MANUAL** to properly start up the air handler.

NOTE: All models have factory installed circuit breakers and electric heater kits have field installed circuit breakers. The models are MS, MM, US, UM are configured as follows:

Small cabinet M***18, 24

Medium cabinet M***25, 30, 36

Large cabinet M***37, 42, 48, 60, 72

POWER SUPPLY CONNECTIONS

If the air handler has been installed prior to installing the electric heaters or if an older air handler is being replaced, the existing supply power wires must be checked to make sure they are sized properly to handle the current load for the heaters. Refer to Tables 8-11 for correct wire size. If the supply power wire size is incorrect, new wires will need to be installed.

LOW VOLTAGE CONNECTIONS

If the air handler was previously installed, nothing will need to change on the low voltage wiring. If this is a new installation, refer to **SECTION 10** of these instructions.

Models Equipped With Circuit Breakers						
Model No	Cabinet Size	Voltage	Phase	Hertz	Heater kW	Motor
BSXHK05C	Small	208/240	1	60	5	C.T.
BSXHK10C	Small	208/240	1	60	10	C.T.
BMXHK05C	Medium	208/240	1	60	5	C.T.
BMXHK10C	Medium	208/240	1	60	10	C.T.
BMXHK15C	Medium	208/240	1	60	15	C.T.
BLXHK05C	Large	208/240	1	60	5	C.T.
BLXHK10C	Large	208/240	1	60	10	C.T.
BLXHK15C	Large	208/240	1	60	15	C.T.
BLXHK20C	Large	208/240	1	60	20	C.T.
BSEHK05C	Small	208/240	1	60	5	ECM
BSEHK10C	Small	208/240	1	60	10	ECM
BMEHK05C	Medium	208/240	1	60	5	ECM
BMEHK10C	Medium	208/240	1	60	10	ECM
BMEHK15C	Medium	208/240	1	60	15	ECM
BLEHK05C	Large	208/240	1	60	5	ECM
BLEHK10C	Large	208/240	1	60	10	ECM
BLEHK15C	Large	208/240	1	60	15	ECM
BLEHK20C	Large	208/240	1	60	20	ECM

Table 13: Electric Heater Kit Model Numbers

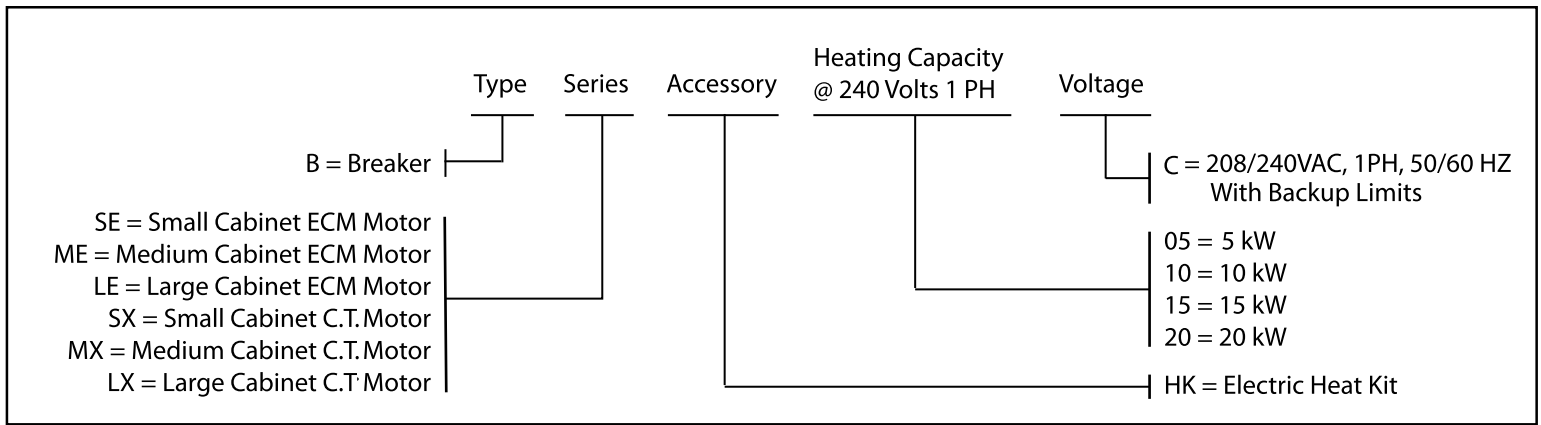

Table 14: Accessory Electric Heater Kit Model Number Nomenclature

CAUTION

To prevent damage, carefully insert the electric heating assembly through the rectangular opening in the front of the discharge opening so the heat element support rod is seated into the hole on the back side of the discharge opening.

CAUTION

After installing the electric heater, a one-inch clearance must be maintained on all sides of the supply air duct and/or plenum for a minimum of 36 inches from the air handler discharge opening

SECTION 10: THERMOSTAT WIRING AND CONNECTIONS

Thermostat Wiring

Thermostat wires connect through the side of air handler and should be no smaller than 22 gauge. Refer to Table 15 for recommended wire gauge, lengths and maximum current for each wire gauge. Thermostat wires can enter through the right side or top of the air handler casing (See Figure 22).. When bringing wiring through the top or side of the air handler casing, cable connectors must be installed to hold wiring in place and to relieve any strain on the wiring.

Max. Thermostat Wire Length	Thermostat Wire Gauge	Thermostat Wire Maximum Current
0 - 100 Feet	22	3.0 Amps
0 - 125 Feet	20	3.0 amps
0 - 250 Feet	18	3.0 amps

Table 15: Low Voltage Wire Gauge and Max Lengths

The use of an 8 conductor cable from the thermostat to the air handler is recommended. The thermostat wire colors and the typical heating/cooling connections are listed in Table 16. The thermostat wire colors and the typical heat pump connections are listed in Table 17.

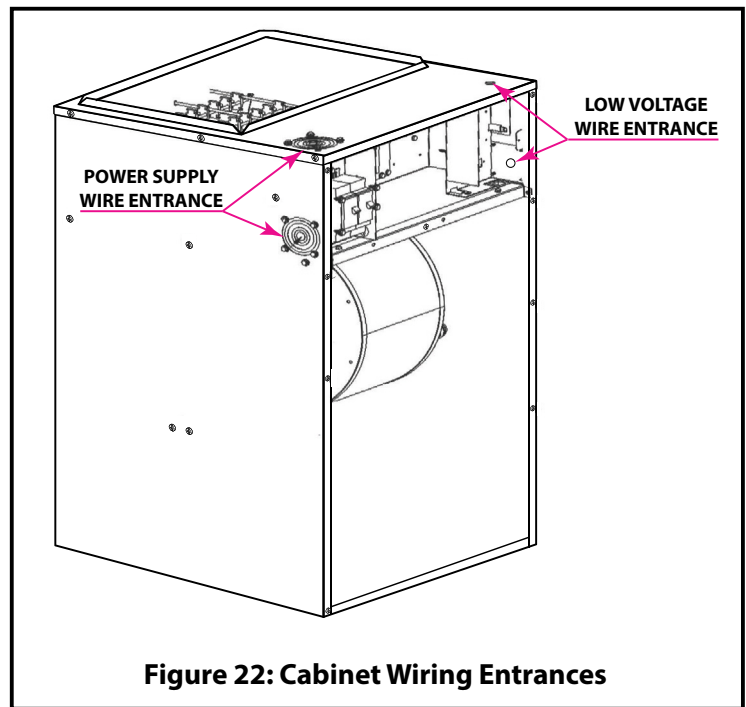

Figure 22: Cabinet Wiring Entrances

Thermostat Installation

The thermostat should be located on an inside wall in an open area to more closely regulate average room air, preferably where there is air movement back to air handler. Locating height of thermostat is important. If possible, the thermostat should be located in a hallway upstream from the air handler return airflow, not within 3 feet of from any windows, and 52 to 66 inches above the floor. Do not place the thermostat within three feet of any of the air-distribution supply air registers.

Maintenance, operating and/ or programming instructions are in the envelope accompanying the thermostat. Give the envelope to the homeowner.

⚠ CAUTION

Do not locate thermostat within 3 feet of any of the following items:

1. Air distribution supply air registers
2. Lights or heat lamps
3. Aquariums
4. Televisions, stereo, amplifiers, surround sound systems
5. Stoves or any cooking appliance
6. Refrigerator
7. Washer and/or dryer
8. Water heater tank
9. Sink or near any hot water
10. Within 15 feet of any electric space heater
11. Within two feet of any sunlight

Air Handler and Outdoor Unit With Separate Transformers

If the air-handler and the outdoor unit have separate transformers, it is important to use a thermostat with isolated heating and cooling terminals "RC" and "RH" to prevent interconnection of separate Class II 24VAC control systems. These thermostats have an "RC" terminal for cooling and an "RH" terminal for heating. Connect the outdoor unit RED wire from the "R" terminal on the outdoor unit to the "RC" terminal on the thermostat and the RED air handler pigtail wire to the "RH" terminal on the thermostat. Remove the jumper between the "RH" and "RC" terminals if one exists. If the air handler

and outdoor unit using separate transformers are both connected to the thermostat single "R" terminal, or if the jumper between "RH" and "RC" is not removed, a transformer burnout can occur or either the air handler or outdoor unit control system could go into lockout mode. If an air handler and outdoor unit with separate transformers are being installed and the thermostat does not have "RC" and "RH" terminals, a new thermostat with "RC" and "RH" terminals must be purchased and installed.

IMPORTANT: Cycle the air handler and outdoor unit separately to make sure both operate correctly.

Thermostat Heat Anticipator

Some thermostats have a heat anticipator setting that must be set to the settings shown below in order to function correctly. If the heat anticipator setting is too low, the system will short cycle. If the heat anticipator setting is too high, the system will run long heat cycles thus causing the temperature to overrun the temperature setting. This will cause the homeowner or user to feel too warm by the time the blower completes its cycle and too cold by the time the system cycles on again. The heat anticipator should be set to 0.4 for all heating kW's.

The thermostat may be a "self-setting" type in which no heat anticipator will be found on the thermostat, eliminating the need for field adjustment.

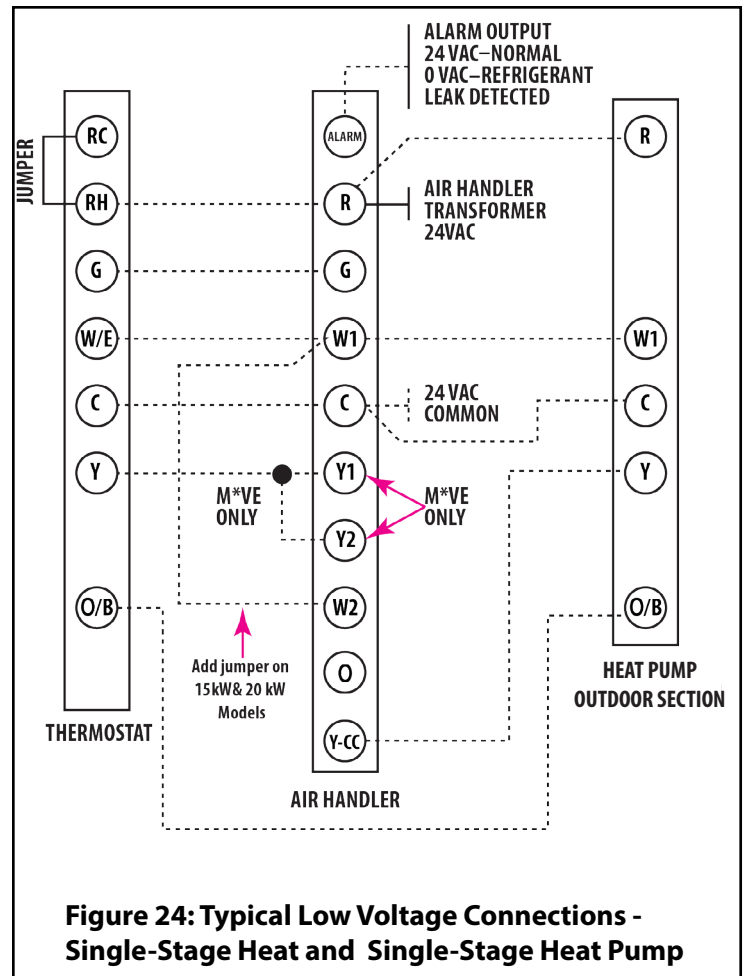
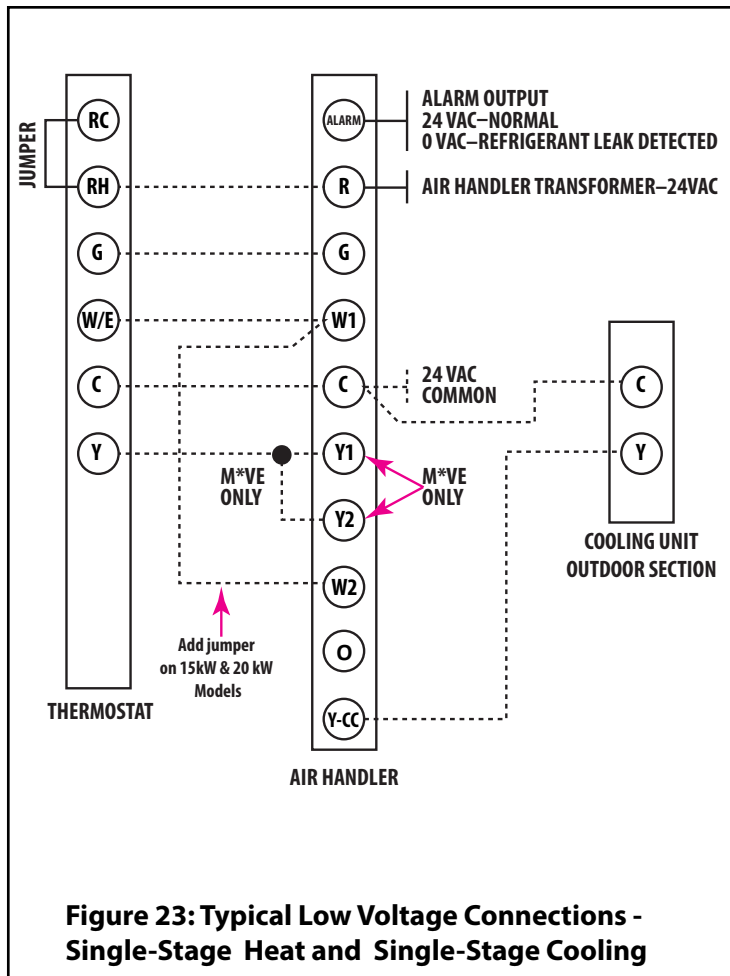

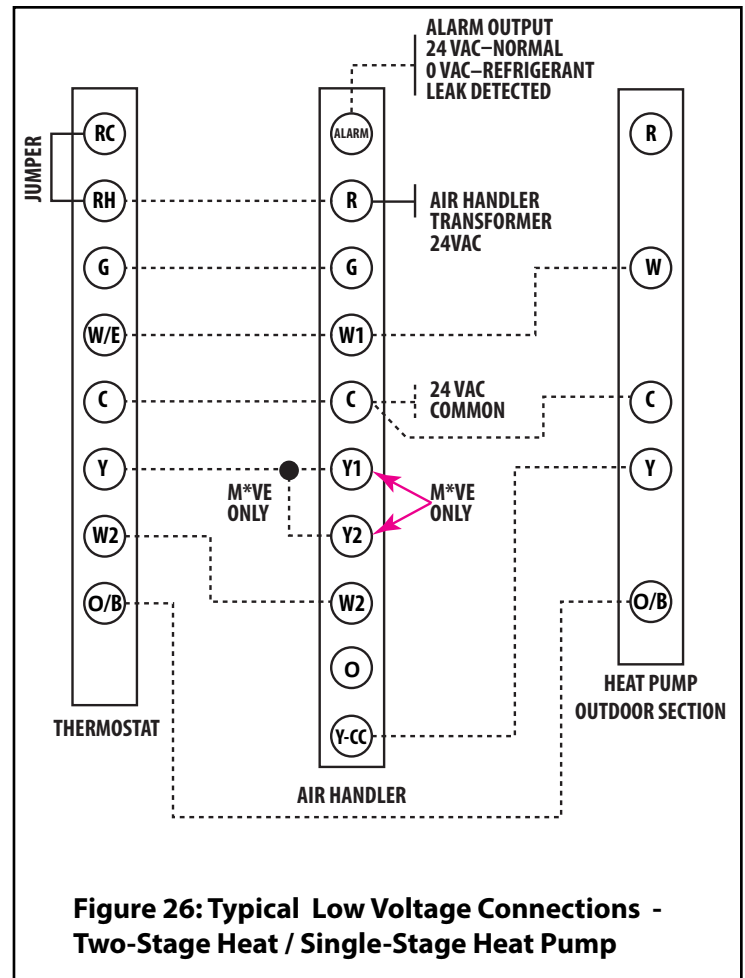
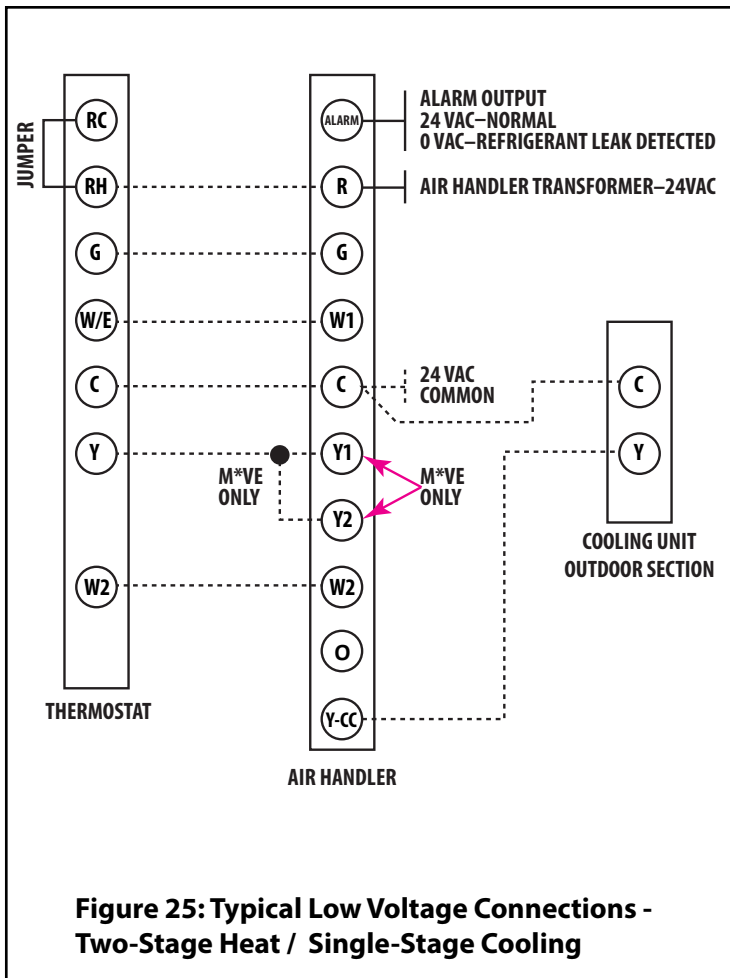

Figure 25: Typical Low Voltage Connections - Two-Stage Heat / Single-Stage Cooling

Figure 26: Typical Low Voltage Connections - Two-Stage Heat / Single-Stage Heat Pump

DESCRIPTION	LETTER CODE	AIR HANDLER PIG TAIL WIRE CONNECTION	THERMOSTAT AND AIR HANDLER TERMINAL BLOCK CONNECTION	OUTDOOR UNIT CONNECTIONS
24 VAC	R	RED	R	N/A
1st Stage Heat	W1	WHITE	W or W1	N/A
2nd Stage Heat	W2	BLACK	W2	N/A
Indoor Fan	G	GREEN	G	N/A
Cooling/1st Stage Cooling	Y/Y1	YELLOW	Y/Y1	N/A
Optional 2nd Stage Cooling	Y2	BLUE	Y2	Y2
24 VAC Common	C	BROWN	C	C
Y-Out to Outdoor Unit	Y-CC	WHITE	N/A	Y/Y1
Refrigerant Leak Alarm	ALARM	ORANGE	See Refrigerant Leak Alarm Output Section on Page 20	N/A

Table 16: Typical Heat / Cool Thermostat Wire Colors and Low Voltage Connections

Note: If a single-stage heat thermostat is used with an air handler with two-stage heat, install a jumper between W1 and W2 on the low voltage terminal block or connect the W1 and W2 pigtail wires together with the WHITE thermostat wire.

DESCRIPTION	LETTER CODE	AIR HANDLER PIGTAIL WIRE CONNECTION	THERMOSTAT AND AIR HANDLER TERMINAL BLOCK CONNECTION	OUTDOOR UNIT CONNECTIONS
24 VAC	R	RED	R	R
1st Stage Electric Heat	W1	WHITE	E (Thermostat) W1 (Air Handler)	See Outdoor Unit Instructions
2nd Stage Electric Heat	W2	BLACK	W2	N/A
Indoor Fan	G	GREEN	G	N/A
Cooling /1st Stage Cooling	Y/Y1	YELLOW	Y/Y1	N/A
Optional 2nd Stage Cooling	Y2	BLUE	Y2	Y2
Heat Pump Reversing Valve (Most Brands)	O	N/A	O	See Outdoor Unit Instructions
Heat Pump Reversing Valve (Some Brands)	B	N/A	B	See Outdoor Unit Instructions
24 VAC Common	C	BROWN	C	C
Y-Out to Outdoor Unit	Y-CC	WHITE	N/A	Y/Y1
Refrigerant Leak Alarm	ALARM	ORANGE	See Refrigerant Leak Alarm Output Section on Page 20	N/A

Table 17: Typical Heat Pump Thermostat Wire Colors and Low Voltage Connections

Typical Heating/Cooling Thermostat Wiring Connections

1. Remove blower / control box access panel.
2. Remove the control box cover.
3. Insert the wire cables from the thermostat and outdoor unit through the 9/16" diameter hole located in the top or side of the air handler and into the control box. Place the thermostat wire cable next to the air handler low voltage terminal block (LVTB) or low voltage pigtailed. Secure the thermostat and outdoor unit wire cables in the 9/16" diameter hole with a strain relief to prevent wire connections from being pulled apart.
4. Strip 1/2" of the insulation on the end of each wire.
5. Connect the RED (24 VAC) supply thermostat wire to the "R" terminal on the LVTB or to the RED air handler pigtail wire and secure with a wire nut.
6. Connect the WHITE (first stage heating) thermostat wire to the "W1" terminal on the LVTB or to the WHITE air handler pigtail wire and secure with a wire nut.
7. Connect the GREEN wire from the thermostat "G" terminal thermostat wire to the "G" terminal on the LVTB or to the GREEN air handler pigtail wire and secure with a wire nut.
8. For M*VT models, connect the YELLOW wire from the thermostat "Y" terminal to the "Y" terminal on the LVTB.
9. For M*VE models (ECM motor), connect the YELLOW wire from the thermostat to both the YELLOW "Y1" and BLUE "Y2" air handler pigtailed with a wire nut for single-stage cooling applications to assure full nominal airflow. For 2-stage cooling applications, connect the wires from the thermostat "Y1" terminal to the YELLOW "Y1" air handler pigtail and connect the wire from the thermostat "Y2" terminal to the BLUE "Y2" air handler pigtail.
10. Connect the WHITE air handler pigtail labeled "Y-CC" to the wire from the outdoor unit compressor contactor coil with a wire nut.
11. Connect the BROWN 24 VAC common wire from the thermostat "C" terminal to the "C" terminal on the LVTB (M*VT) or to the BROWN air handler 24 VAC common pigtail (M*VE) with a wire nut. Also connect the 24 VAC common wire from the outdoor unit compressor contactor coil to the "C" terminal on the LVTB (M*VT) or to the BROWN air handler 24 VAC common pigtail (M*VE) with a wire nut.

12. For 15kW and 20kW models, connect the BLUE wire from the thermostat "W2" terminal (2nd stage heat) to the "W2" terminal on the LVTB (M*VT) or to the BLACK air handler pigtail wire (M*VE) and secure with a wire nut.

NOTE: If a single-stage heat thermostat is used with an air handler with 15kW or 20kW of electric heat, place a jumper between the "W1" and "W2" terminals on the LVTB (M*VT) or connect the BLACK and the WHITE air handler pigtail wires (M*VE) to the WHITE wire from the thermostat "W" terminal with a wire nut.

13. If a refrigerant leak alert is desired and a building management system or smart thermostat capable of providing that alert is being used, removed the wire nut from the end of the ORANGE pigtail wire labeled "ALARM" and connect it to the appropriate building management system or smart thermostat connections. A field supplied normally closed relay and warning light or audible alarm may also be connected to the ORANGE sensor wire labeled "ALARM" as shown in Figure 17. See "Refrigerant Leak Alarm Output" on page 20 for additional information.

Typical Heat Pump - Heating/Cooling Thermostat Wiring Connections

1. Remove the blower / control box access panel.
2. Remove the control box cover.
3. Insert the wire cables from the thermostat and outdoor unit through the 9/16" diameter hole located on the top or side of the air handler and into the control box. Place the thermostat and outdoor unit wire cables next to the air handler low voltage terminal block (LVTB) or low voltage pigtailed. Secure the thermostat and outdoor unit wire cable with a strain relief in the 9/16" diameter hole to prevent wire connections from being pulled apart.
4. Strip 1/2" of the insulation on the end of each wire.
5. Connect the RED (24 VAC) wire from the thermostat "R" terminal to the "R" terminal on the LVTB or to the RED air handler pigtail wire and with the wire from the "R" terminal or pigtail on the outdoor unit. Fasten the three wires together securely with a wire nut.
6. Connect the WHITE (emergency heat) wire from the thermostat

“E” terminal to the “W1” terminal on the air handler LVTB or to the WHITE air handler pigtail wire with a wire nut. If applicable, also connect the wire from the outdoor control board that calls for supplemental heat during the defrost cycle to the “W1” terminal on the air handler LVTB or to the WHITE air handler pigtail wire. Refer to the outdoor unit installation instructions for additional information.

7. Connect the GREEN wire from the thermostat “G” terminal to the “G” terminal on the LVTB or to the GREEN air handler pigtail wire and securely fasten the two wires together with a wire nut.
8. For M*VT models, connect the YELLOW wire from the thermostat “Y” terminal to the “Y” terminal on the LVTB.
9. For M*VE models (ECM motor), connect the YELLOW wire from the thermostat to both the YELLOW “Y1” and BLUE “Y2” air handler pigtails with a wire nut for single-stage cooling applications to assure full nominal airflow. For 2-stage cooling applications, connect the wires from the thermostat “Y1” terminal to the YELLOW “Y1” air handler pigtail and connect the wire from the thermostat “Y2” terminal to the BLUE “Y2” air handler pigtail.
10. Connect the WHITE air handler pigtail labeled “Y-CC” to the wire from the outdoor unit compressor contactor coil with a wire nut.
11. Connect the BROWN 24 VAC common wire from the thermostat “C” terminal to the “C” terminal on the LVTB (M*VT) or to the BROWN air handler 24 VAC common pigtail (M*VE) with a wire nut. Also connect the 24 VAC common wire from the outdoor unit compressor contactor coil to the “C” terminal on the LVTB (M*VT) or to the BROWN air handler 24 VAC common pigtail (M*VE) with a wire nut.
12. Connect the wire from the thermostat “O” or “B” terminal with the wire from the outdoor unit “O” or “B” terminal or pigtail with a wire nut. Refer to the outdoor unit installation instructions for additional information.
13. For 15kW and 20kW models, connect the BLACK wire from the thermostat “W2” terminal (2nd stage heat) to the “W2” terminal on the LVTB (M*VT) or to the BLACK air handler pigtail wire (M*VE) and secure with a wire nut.

NOTE: If a single-stage heat thermostat is used with an air handler with 15kW or 20kW of electric heat, place a jumper between the “W1” and “W2” terminals on the LVTB (M*VT) or connect the BLACK and the WHITE air handler pigtail wires (M*VE) to the WHITE wire from the thermostat “W” terminal with a wire nut.

14. If a refrigerant leak alert is desired and a building management system or smart thermostat capable of providing that alert is being used, removed the wire nut from the end of the ORANGE pigtail wire labeled “ALARM” and connect it to the appropriate building management system or smart thermostat connections. A field supplied normally closed relay and warning light or audible alarm may also be connected to the ORANGE sensor wire labeled “ALARM” as shown in Figure 17. See “Refrigerant Leak Alarm Output” on page 20 for additional information

SECTION 11: BLOWER PERFORMANCE

Model Number	Motor HP	Volts 1 Ph. 60 Hz	Motor Code	Blower Wheel	Speed Tap	CFM @ 0.10" ESP	CFM @ 0.20" ESP	CFM @ 0.30" ESP	CFM @ 0.40" ESP	CFM @ 0.50" ESP	CFM @ 0.60" ESP
M*VT18 Electric Heat	0.33	208/240	VD1	10 X 7	1	699	639	565	536	451	402
					2	741	676	592	517	527	458
					3	908	849	777	679	745	655
					4	1022	963	905	840	761	703
					5	1102	1054	996	928	884	812
M*VT24 Electric Heat	0.33	208/240	VD1	10 X 7	1	861	786	708	638	547	615
					2	924	872	814	726	663	656
					3	1067	1013	963	894	826	758
					4	1139	1093	1042	982	918	857
					5	1220	1157	1105	1049	985	893
M*VT25 Electric Heat	0.50	208/240	VE1	10 X 8	1	995	934	855	793	712	649
					2	1047	994	926	876	782	700
					3	1146	1075	1019	957	880	811
					4	1224	1161	1099	1030	972	904
					5	1300	1247	1186	1115	1058	996
M*VT30 Electric Heat	0.50	208/240	VE1	10 X 8	1	898	829	784	741	691	604
					2	999	962	918	888	847	811
					3	1164	1120	1087	1060	1022	990
					4	1260	1222	1197	1162	1131	1098
					5	1353	1321	1289	1258	1229	1197
M*VT36 Electric Heat	0.50	208/240	VE1	10 X 8	1	1161	1135	1086	1056	1027	992
					2	1261	1228	1198	1153	1129	1100
					3	1361	1310	1286	1262	1227	1201
					4	1478	1431	1405	1383	1351	1309
					5	1568	1536	1507	1470	1440	1400
M*VT37 Electric Heat	0.75	208/240	VF1	12 X 9	1	1466	1406	1249	1198	1150	1075
					2	1487	1454	1383	1328	1291	1231
					3	1516	1508	1462	1415	1365	1319
					4	1588	1600	1569	1520	1471	1423
					5	1672	1672	1657	1619	1557	1520
M*VT42 Electric Heat	0.75	208/240	VF1	12 X 9	1	1483	1458	1370	1315	1267	1238
					2	1524	1503	1445	1392	1343	1286
					3	1587	1607	1556	1512	1466	1423
					4	1671	1648	1667	1607	1572	1532
					5	1707	1685	1722	1678	1633	1599
M*VT48 Electric Heat	0.75	208/240	VF1	12 X 9	1	1579	1560	1544	1491	1445	1397
					2	1685	1671	1626	1587	1544	1507
					3	1739	1746	1711	1674	1629	1579
					4	1802	1778	1809	1764	1718	1682
					5	1876	1870	1896	1870	1836	1782
M*VT60 Electric Heat	0.75	208/240	VF1	12 X 9	1	1579	1560	1544	1491	1445	1397
					2	1685	1671	1626	1587	1544	1507
					3	1745	1734	1745	1712	1656	1616
					4	1958	1953	1943	1919	1874	1828
					5	2038	2015	2010	2005	1977	1934
M*VT72 Electric Heat	1.00	208/240	VV	12 X 10	1	1910	1865	1826	1787	1750	1715
					2	2088	2054	2019	1969	1932	1895
					3	2240	2201	2162	2129	2088	2050
					4	2370	2339	2290	2246	2208	2170
					5	2504	2470	2441	2393	2351	2310

Table 18: M*VT Blower Performance Chart - Constant Torque Motors - Without Air Filter

Note: 1) Minimum CFM for Electric Heat: 5 - 10kW = 650 CFM; 15kW = 1000 CFM; 20 kW = 1400 CFM

2) For MM Series air handlers, the ESP in the table assumes a typical indoor coil has been installed on the air handler.

Model Number	Nominal Tons	Motor HP	Volts 1 Ph. 50/60 Hz.	Motor Code	Blower Wheel	Jumper	CFM @ 0.10"	CFM @ 0.20"	CFM @ 0.30"	CFM @ 0.40"	CFM @ 0.50"
M*VE18,24 Electric Heat	1.5 - 2.0	1/3	208/240	VA	9 X 6	A	837	837	824	817	806
						B	744	733	721	717	713
						C	705	697	689	681	677
						D	634	620	615	611	602
M*VE25,30,36 Electric Heat	1.5 - 3.0	1/2	208/240	VB	10 X 7	A	1422	1421	1421	1416	1416
						B	1215	1214	1214	1214	1208
						C	898	989	989	982	969
						D	865	865	865	866	858
M*VE37,42,48,60 Electric Heat	5.0	3/4	208/240	VC	12 X 9	A	1957	1919	1900	1871	1847
						B	1576	1565	1547	1517	1487
						C	1495	1482	1451	1432	1409
						D	1411	1385	1372	1338	1311
M*VE72 Electric Heat	6.0	1	208/240	VU	12 X 10	A	2393	2393	2393	2393	2388
						B	2227	2227	2221	2221	2221
						C	2012	2012	2005	2005	2005
						D	1795	1795	1795	1795	1795

Table 19: M*SV Blower Performance Chart - ECM Motors (Y1+Y2, W1, or W2) - Without Air Filter

- Notes: 1) For single-stage cooling/heat pump systems, connect the wire from the "Y" thermostat terminal to both the "Y1" and "Y2" air handler low voltage pigtailed to assure full nominal airflow.
- 2) "Y1" CFM (1st stage cooling/heat pump heating) is approximately 70% of the values shown in Table 19.
- 3) Continuous fan CFM is approximately 50% of the values shown in Table 19.
- 4) Minimum CFM for Electric Heat: 5 - 10kW = 650 CFM; 15kW = 1000 CFM; 20 kW = 1400 CFM
- 5) For MM Series air handlers, the ESP in the table assumes a typical indoor coil has been installed on the air handler.

SECTION 12: MOTOR SPEED SELECTION AND AIR HANDLER STARTUP

Notice: Refer to the blower performance tables in Section 11 of this manual when selecting the motor speed for a specific application.

! WARNING

To avoid personal injury or property damage, make certain that the motor leads cannot come into contact with non-insulated metal components of the air handler.

! WARNING

This air handler is equipped with a refrigerant leak mitigation system that energizes the blower motor to deliver at least the required minimum airflow when the refrigerant leak detection system detects a leak (See Tables 22 and 23). This will dilute the flammable A2L class refrigerant to a point that it no longer poses a risk of an explosion or fire. Follow the procedure in Section 13: System Startup and Check-Out to confirm the refrigerant mitigation system is functioning as it should.

Selecting the Constant Torque Motor Speed

The constant torque motor operates on 208/240 VAC and the motor speed taps are controlled by 24 VAC. The speed taps can be changed by moving the BLACK and RED wires to different terminals on the motor terminal block (terminals 1 – 5). Table 20 shows the constant torque motor lead connection labeling and the connection definitions.

Changing Motor Speeds – Constant Torque Motor

1. Turn off all electrical supply circuits to the air handler at the main electrical panel.
2. Switch the air handler circuit breaker(s) to "OFF".
3. Remove the blower access panel.
4. Move the BLACK and RED wires connected to terminals 1-5 on the motor terminal block (See Figure 27) to the desired speed taps. See Table 21 for the speed tap descriptions. Reinstall the blower access panel.
5. Turn the air handler circuit breakers to "ON".
6. Turn on all electrical supply circuits to the air handler at the main electrical panel.
7. Set the thermostat to the desired operating mode and temperature.

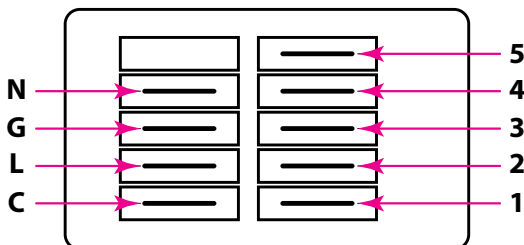

Figure 27: Constant Torque Motor Terminals

Terminal	Connection
C	Speed Tap Common - 24 VAC Common
L	Supply Voltage - 208/240 Vac Line 1
G	Ground Connection
N	Supply Voltage - 208/240 Vac Line 2
1	Low Speed Tap - 24 VAC Input
2	Medium-Low Speed Tap - 24 VAC Input
3	Medium Speed Tap - 24 VAC Input
4	Medium-High Speed Tap - 24 VAC Input
5	High Speed Tap - 24 VAC Input

Table 20: Constant Torque Motor Terminal Connections

Changing Motor Speeds – ECM Motor

1. Turn off all electrical supply circuits to the air handler at the main electrical panel.
2. Switch the air handler circuit breaker(s) to "OFF".
3. Remove the blower access panel.
4. Remove the control box cover.
5. Motor speed can be changed for both heating and cooling modes by moving the jumper on the "COOL" and "HEAT" jumper pins (See Figure 28) on the ECM control board to a different setting. Pin setting is as follows:
A = High Speed, B = Medium High Speed, C = Medium Speed, and D = Low Speed.
6. The ADJUST pin (See Figure 28) is used to increase or decrease the cooling and heating blower motor CFM by 10-12% by moving the pin from the NORMAL position to either the + or - setting.
7. Reinstall the control box cover and blower box access panel.
8. Switch the air handler circuit breaker(s) to "ON".
9. Turn on all electrical supply circuits to the air handler at the main electrical panel.
10. Set the thermostat to the desired operating mode and temperature.

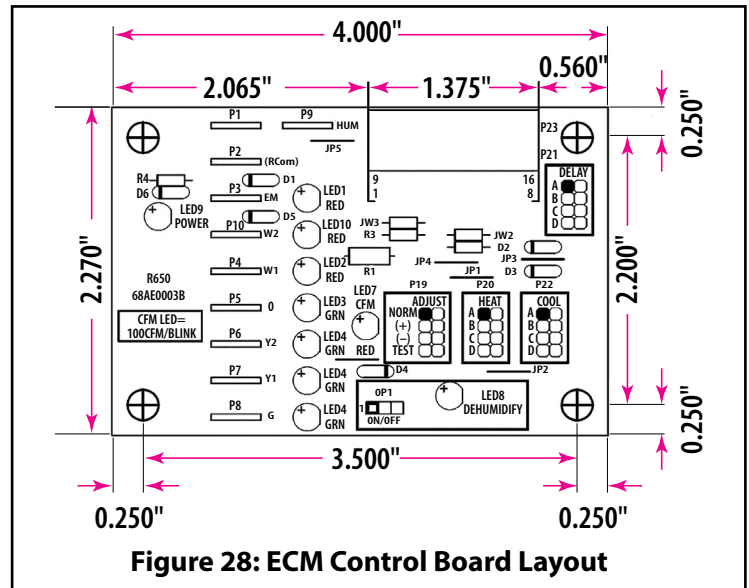

Figure 28: ECM Control Board Layout

1. Common C1
2. W/W1
3. Common C2
4. Delay Tap Select
5. Cool Tap Select
6. Y1
7. Adjust Tap Select
8. Output –
9. Reversing Valve (Heat Pump Only)
10. Humidistat (BK)
11. Heat Tap Select
12. 24 VAC (R)
13. 2nd Stage Heat (EM/W2)
14. 2nd Stage Cool (Y/Y2)
15. Fan (G)
16. Output +COOL setting.

Table 21: ECM Motor Control Connector Terminal Descriptions

Dehumidify– The ECM control board has a jumper pin (OP1, See Figure 28) that can be selected to provide on demand dehumidification for the cooling system. If the jumper pin is moved the ON position, a 24 VAC signal must be present from a dehumidifying thermostat or humidistat when the humidity is below the set point. The humidistat contacts must open when humidity is above the set point.

Dehumidification can be enabled by moving the jumper pin from the OFF position to the ON position. Once the jumper pin has been changed to the ON position, the humidistat will turn the dehumidify program in the motor on and off. When humidification is called for by the thermostat or humidistat, the blower CFM will be reduced by 10-12%. The LED on the ECM control board will be lit when the motor is in the “dehumidify” mode.

If the ECM motor dehumidify program is not desired by the homeowner or user, move the jumper pin back to the “OFF” position to disable the motor program.

The **PROFILES** jumper pins are used for blower motor on and off delays. See Climate Profiles in the back of the **SERVICE AND MAINTENANCE MANUAL** of this manual to determine the proper setting for the climate in the area where the air handler is being installed.

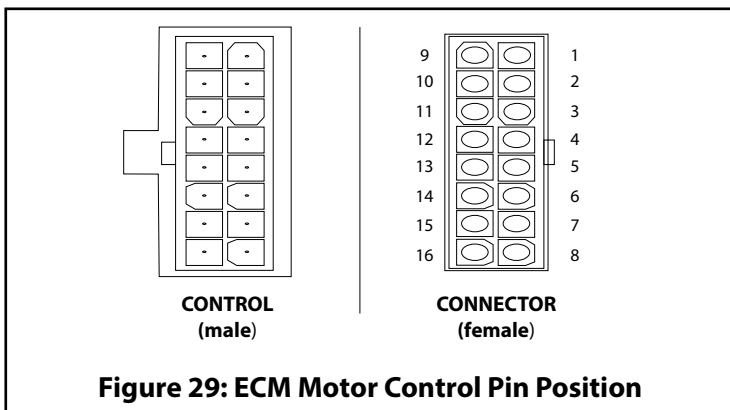

Figure 29: ECM Motor Control Pin Position

ECM Control Board Flash Code

The ECM control board has a CFM flash code when the air handler is in operation to indicate the current CFM. Typically flashes once per 100 CFM.

- To determine the selected CFM, count the number of flashes between pause flashes and multiply by 100.
- The sequence is followed by a 10 second OFF period signifying the end of the flash code, then the flash code starts over.

Note: Since static pressure will be low due to the removed access panel, the blower RPM will be lower to maintain the selected CFM. Example of the flash code:

The air handler is operating at 1400 CFM. The flash code will be 1 second flashes with pulse flashes, 0.1 seconds apart, 14 times, followed by a 10 second off, then the flash code starts over.

⚠ WARNING

The test setting on the ADJUST jumper pins must not be used except for trouble shooting to determine if the blower operates.

SECTION 13: FINAL SYSTEM CHECKOUT

Refer to appropriate wiring diagram and recheck all wiring connections. Ensure that all wiring connections are secure.

1. Check blower motor connectors to make sure they are not damaged or loose.
2. If the control box cover was removed; reinstall control box cover.
3. Switch circuit breaker(s) to “ON” position.
4. Switch the air handler circuit breakers in the main electrical panel to the ON position.
5. Set the blower selector switch on the thermostat to the ON position and check all of the duct connections for air leaks. Seal any air leaks found.
6. Set the blower selector switch on the thermostat to the AUTO position.
7. Set the thermostat above the room temperature to check for proper operation of the electric heaters.
8. Set the thermostat to the desired temperature.

Verifying Proper Functioning of Refrigerant Leak Mitigation System

A test to confirm the proper functioning of the refrigerant leak mitigation system must be performed at the final system checkout. Follow the procedure below to perform that test.

1. Remove the coil access panel from the front of the air handler.
2. Locate the black refrigerant sensor located near the bottom front of the coil assembly (see Figure 16).

Leak Detected During Cooling Cycle

3. Set the thermostat to “COOL” and the fan switch to “AUTO” and lower the temperature setpoint below the indoor temperature so the system enters the cooling mode.
4. Confirm the outdoor unit compressor is operating.
5. Within 30 seconds of the compressor starting, release a small amount of refrigerant on the refrigerant sensor to activate the leak mitigation mode.
6. Confirm the outdoor unit compressor and fan motor shut down and the indoor blower continues to operate.

7. Confirm the indoor blower is energized and 24V is not present at the ORANGE refrigerant leak detection sensor pigtail labeled "ALARM".
8. Confirm the outdoor unit compressor and fan motor are re-energized approximately 5 minutes after the flow of refrigerant near the sensor has ended and that the indoor blower continues to operate.

Leak Detected During the OFF Cycle

9. Set the thermostat to the "OFF" position and wait until the outdoor unit compressor and fan motor stop and indoor blower stops.
10. Release a small amount of refrigerant on the refrigerant sensor to activate the leak mitigation mode.
11. Confirm the indoor blower is energized and 24V is not present at the ORANGE refrigerant leak sensor pigtail marked "ALARM".
12. Confirm the indoor blower shuts down after approximately minutes after the flow of refrigerant on the refrigerant sensor has ended.
13. If the Refrigerant Leak Mitigation System does not operate as stated above, check for loose wiring connections or replace the refrigerant sensor.
14. Reinstall the coil access panel on the air handler.
15. Set the thermostat to the desired operating mode and temperature.

If the leak detection system does not function properly when subjected to the above procedure, check for miswiring of the system. If the wiring connections are found to be correct per the coil or air handler wiring diagram, replace the sensor with an approved replacement from the manufacturer.

Leak Detection Sensor Replacement

When the refrigerant leak detection system sensor fails or reaches the end of its life, the leak detection system will enter and remain in the leak mitigation mode even though there is no refrigerant leak present. If the leak detection system continues to operate in the mitigation mode even when a refrigerant leak isn't indicated by a portable refrigerant leak detector, replace the sensor with an approved replacement from the air coil manufacturer. Disconnect the wiring harness connector from the failed sensor and remove the sensor mounting screws. Discard the failed sensor. Mount the replacement sensor in the same location as the failed sensor that was removed and connect the sensor wiring harness connector to the sensor. Verify the proper function of the refrigerant leak mitigation system using the "**Verifying Proper Functioning of Refrigerant Leak Mitigation System**" procedure above.

IMPORTANT: Mortex may source sensors from various manufacturers that have a different wiring harness connection. A wiring adapter may be necessary to allow the replacement sensor to connect the sensor wiring harness. The wiring adapter will be provided with the replacement sensor. Alternate mounting holes are provided in the sensor bracket to accommodate the various approved sensors. Only use a replacement sensor approved by and provided by Mortex to assure proper operation and compatibility.

Only the following replacement refrigerant sensors may be used for Mortex products:

R-32 Refrigerant: R68ALL001

R-454B Refrigerant: R68ALL002

R-32/R-454B Refrigerant (Dual Refrigerant Sensor): R68ALL003

IMPORTANT: The refrigerant detection system sensor wiring harness plug must be pointing down or horizontal. If the plug is pointing up, water could collect in the plug and result in operational issues. This does not apply to Cubic brand sensors which have a water tight plug and will be pointing up in horizontal applications.

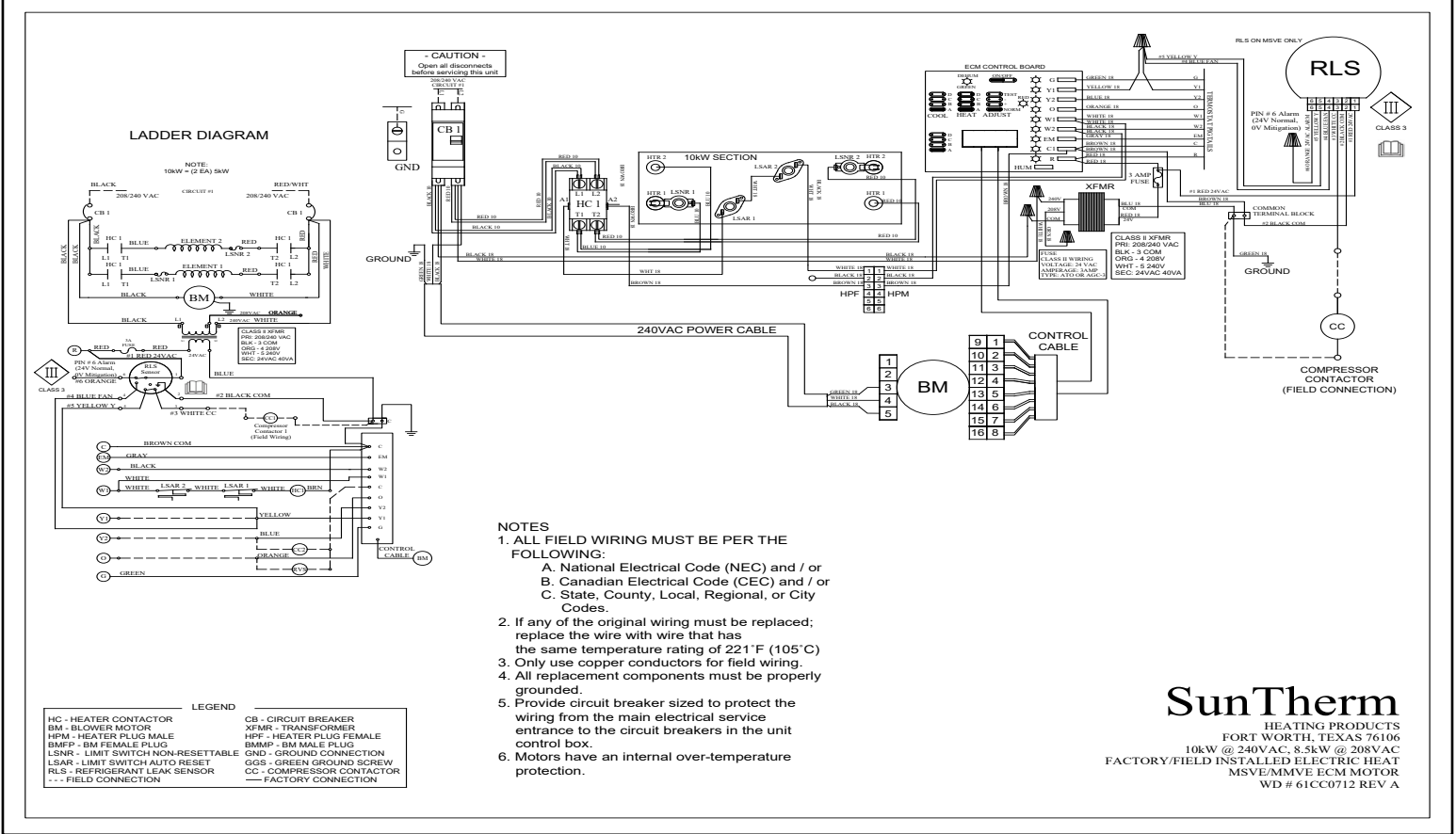

Figure 32: M*VE 18-72 – ECM Motor – 10 kW Electric Heater

SunTherm
 HEATING PRODUCTS
 FORT WORTH, TEXAS 76106
 10kW @ 240VAC, 8.5kW @ 208VAC
 FACTORY/FIELD INSTALLED ELECTRIC HEAT
 MSVE/MMVE ECM MOTOR
 WD # 61CC0712 REV A

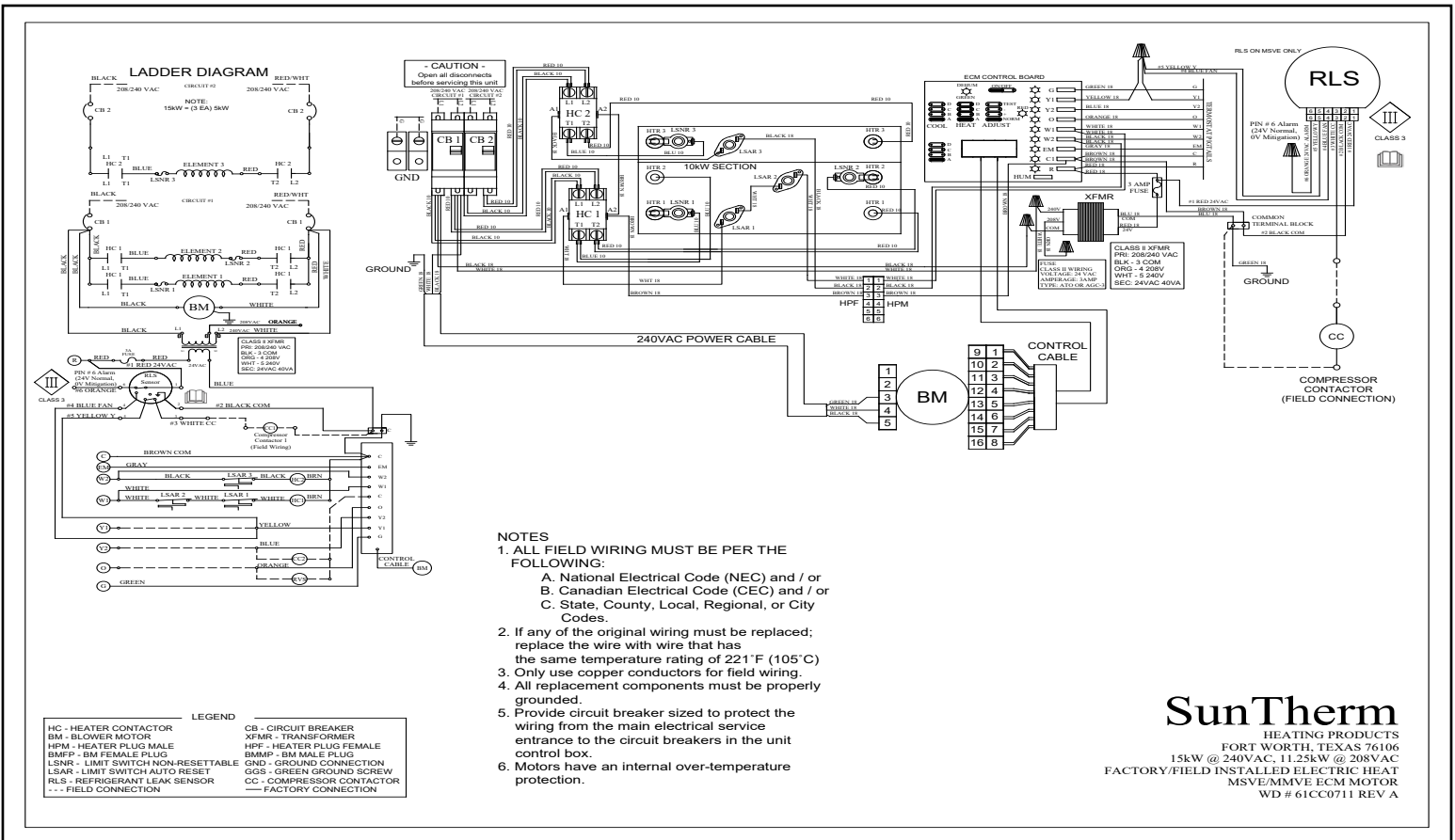

Figure 33: M*VE 25-72 – ECM Motor – 15 kW Electric Heater

SunTherm
 HEATING PRODUCTS
 FORT WORTH, TEXAS 76106
 15kW @ 240VAC, 11.25kW @ 208VAC
 FACTORY/FIELD INSTALLED ELECTRIC HEAT
 MSVE/MMVE ECM MOTOR
 WD # 61CC0711 REV A

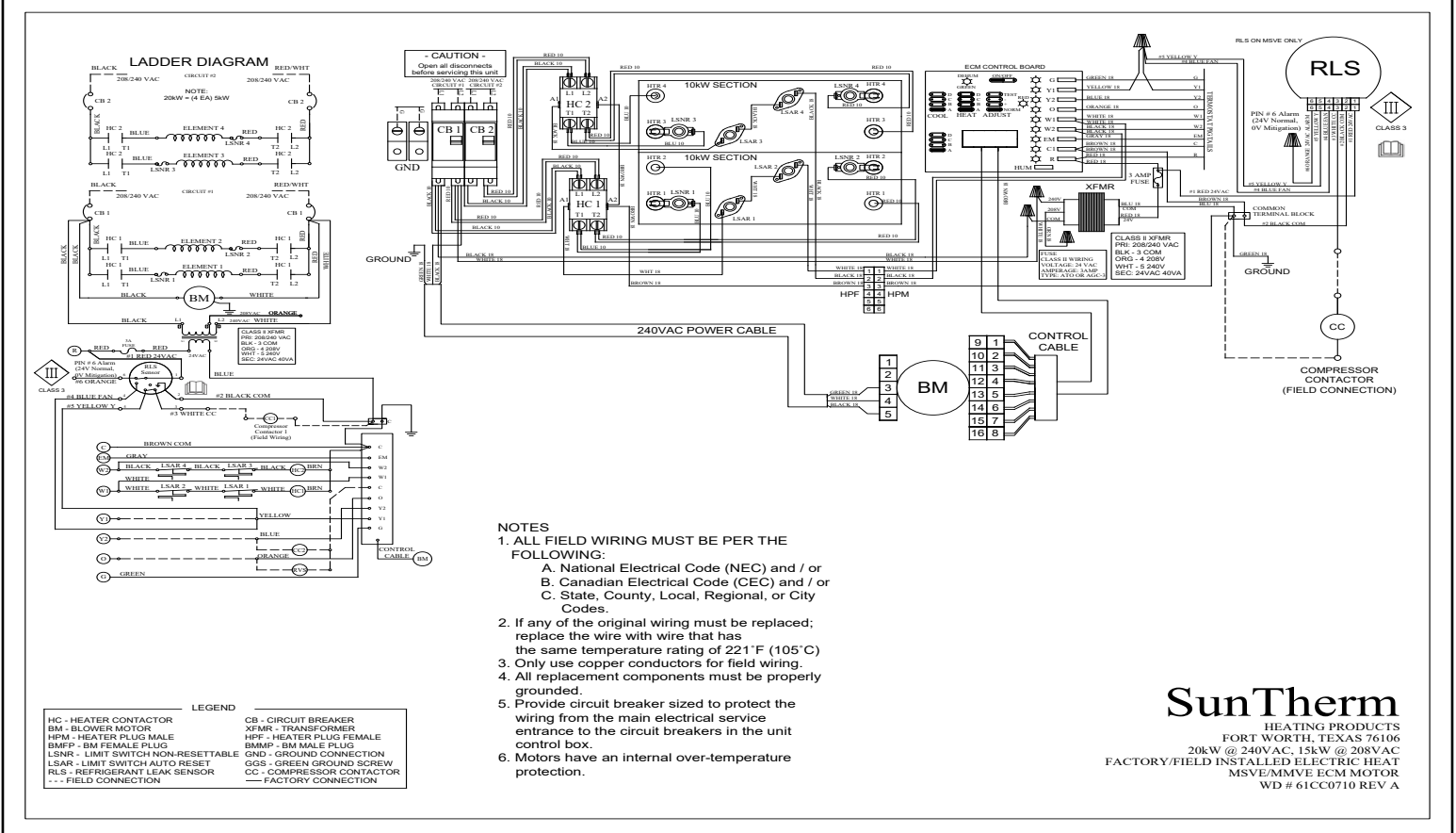

Figure 34: M*VE 37-72 - ECM Motor - 20 kW Electric Heater

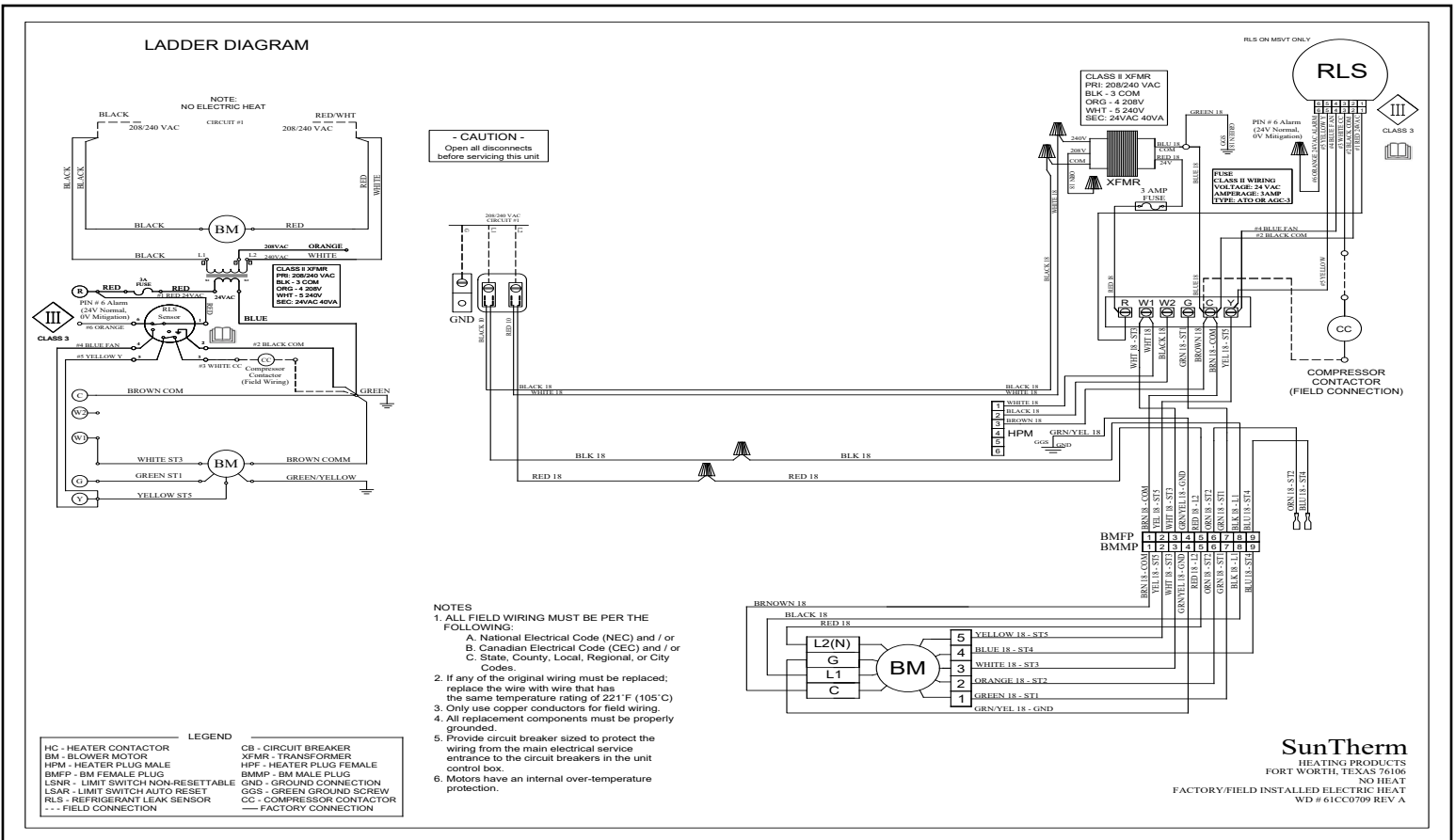

Figure 35: M*VT 18-72 - Constant Torque Motor - No Electric Heater

SECTION 15: MINIMUM CONDITIONED SPACE AND AIRFLOW TABLES

Total System Refrigerant Charge (kg)	Total System Refrigerant Charge (oz)	Total System Refrigerant Charge (lb)	Min. Area of Conditioned Space (m ²)	Min. Area of Conditioned Space (ft ²)	Min. Air-Flow (meter ³ /hr)	Min. Air-Flow (liter/s)	Min. Air-Flow (CFM)
1.776 kg or less	62.6 oz or less	3.91 lb or less	No Minimum	No Minimum	No Minimum	No Minimum	No Minimum
1.78	63	3.92	5.47	59	180	50	106
1.92	68	4.22	5.88	63	194	54	114
2.05	72	4.52	6.30	68	208	58	122
2.19	77	4.82	6.72	72	222	62	131
2.32	82	5.12	7.14	77	236	65	139
2.46	87	5.42	7.56	81	249	69	147
2.60	92	5.72	7.97	86	263	73	155
2.73	96	6.02	8.39	90	277	77	163
2.87	101	6.32	8.81	95	291	81	171
3.00	106	6.62	9.23	99	305	85	179
3.14	111	6.92	9.65	104	318	88	187
3.28	116	7.22	10.06	108	332	92	195
3.41	120	7.52	10.48	113	346	96	204
3.55	125	7.82	10.90	117	360	100	212
3.69	130	8.12	11.32	122	374	104	220
3.82	135	8.42	11.74	126	387	108	228
3.96	140	8.73	12.15	131	401	111	236
4.09	144	9.03	12.57	135	415	115	244
4.23	149	9.33	12.99	140	429	119	252
4.37	154	9.63	13.41	144	442	123	260
4.50	159	9.93	13.83	149	456	127	269
4.64	164	10.23	14.24	153	470	131	277
4.77	168	10.53	14.66	158	484	134	285
4.91	173	10.83	15.08	162	498	138	293
5.05	178	11.13	15.50	167	511	142	301
5.18	183	11.43	15.92	171	525	146	309
5.32	188	11.73	16.33	176	539	150	317
5.45	192	12.03	16.75	180	553	154	325
5.59	197	12.33	17.17	185	567	157	333
5.73	202	12.63	17.59	189	580	161	342
5.86	207	12.93	18.01	194	594	165	350
6.00	212	13.23	18.42	198	608	169	358
6.14	216	13.53	18.84	203	622	173	366
6.27	221	13.83	19.26	207	636	177	374
6.41	226	14.13	19.68	212	649	180	382
6.54	231	14.43	20.10	216	663	184	390
6.68	236	14.73	20.51	221	677	188	398
6.82	240	15.03	20.93	225	691	192	407
6.95	245	15.33	21.35	230	705	196	415
7.09	250	15.63	21.77	234	718	200	423
7.22	255	15.93	22.19	239	732	203	431
7.36	260	16.23	22.60	243	746	207	439
7.50	264	16.53	23.02	248	760	211	447
7.63	269	16.83	23.44	252	774	215	455
7.77	274	17.13	23.86	257	787	219	463
7.90	279	17.43	24.28	261	801	223	471
8.04	284	17.73	24.69	266	815	226	480
8.18	288	18.03	25.11	270	829	230	488
8.31	293	18.33	25.53	275	843	234	496
8.45	298	18.63	25.95	279	856	238	504
8.59	303	18.93	26.37	284	870	242	512
8.72	308	19.23	26.78	288	884	246	520
8.86	312	19.53	27.20	293	898	249	528
8.99	317	19.83	27.62	297	911	253	536

TABLE: 22: MINIMUM CONDITIONED SPACE AREA & AIR-FLOW FOR R-454B REFRIGERANT INSTALLATIONS

NOTES: 1. Applies to fixed ducted systems with continuous air-flow or refrigerant detection systems only.
 2. Based on LFL of 0.306 kg/m³

Total System Refrigerant Charge (kg)	Total System Refrigerant Charge (oz)	Total System Refrigerant Charge (lb)	Min. Area of Conditioned Space (m ²)	Min. Area of Conditioned Space (ft ²)	Min. Air-Flow (meter ³ /hr)	Min. Air-Flow (liter/s)	Min. Air-Flow (CFM)
1.836 kg or less	64.6 oz or less	4.04 lb or less	No Minimum	No Minimum	No Minimum	No Minimum	No Minimum
1.84	65	4.06	5.47	59	180	50	106
1.98	70	4.36	5.87	63	194	54	114
2.11	75	4.66	6.28	68	207	58	122
2.25	79	4.96	6.68	72	220	61	130
2.38	84	5.26	7.08	76	234	65	138
2.52	89	5.56	7.49	81	247	69	145
2.66	94	5.86	7.89	85	260	72	153
2.79	99	6.16	8.30	89	274	76	161
2.93	103	6.46	8.70	94	287	80	169
3.06	108	6.76	9.11	98	300	83	177
3.20	113	7.06	9.51	102	314	87	185
3.34	118	7.36	9.91	107	327	91	193
3.47	123	7.66	10.32	111	341	95	200
3.61	127	7.96	10.72	115	354	98	208
3.75	132	8.26	11.13	120	367	102	216
3.88	137	8.56	11.53	124	381	106	224
4.02	142	8.86	11.94	128	394	109	232
4.15	147	9.16	12.34	133	407	113	240
4.29	151	9.46	12.74	137	421	117	248
4.43	156	9.76	13.15	142	434	121	255
4.56	161	10.06	13.55	146	447	124	263
4.70	166	10.36	13.96	150	461	128	271
4.83	171	10.66	14.36	155	474	132	279
4.97	175	10.96	14.77	159	487	135	287
5.11	180	11.26	15.17	163	501	139	295
5.24	185	11.56	15.57	168	514	143	302
5.38	190	11.86	15.98	172	527	146	310
5.51	195	12.16	16.38	176	541	150	318
5.65	199	12.46	16.79	181	554	154	326
5.79	204	12.76	17.19	185	567	158	334
5.92	209	13.06	17.60	189	581	161	342
6.06	214	13.36	18.00	194	594	165	350
6.20	219	13.66	18.41	198	607	169	357
6.33	223	13.96	18.81	202	621	172	365
6.47	228	14.26	19.21	207	634	176	373
6.60	233	14.56	19.62	211	647	180	381
6.74	238	14.86	20.02	216	661	184	389
6.88	243	15.16	20.43	220	674	187	397
7.01	247	15.46	20.83	224	687	191	405
7.15	252	15.76	21.24	229	701	195	412
7.28	257	16.06	21.64	233	714	198	420
7.42	262	16.36	22.04	237	727	202	428
7.56	267	16.66	22.45	242	741	206	436
7.69	271	16.96	22.85	246	754	209	444
7.83	276	17.26	23.26	250	767	213	452
7.96	281	17.56	23.66	255	781	217	460
8.10	286	17.86	24.07	259	794	221	467
8.24	291	18.16	24.47	263	808	224	475
8.37	295	18.46	24.87	268	821	228	483
8.51	300	18.76	25.28	272	834	232	491
8.65	305	19.06	25.68	276	848	235	499
8.78	310	19.36	26.09	281	861	239	507
8.92	315	19.66	26.49	285	874	243	514
9.05	319	19.96	26.90	290	888	247	522

TABLE 23: MINIMUM CONDITIONED SPACE AREA & AIR-FLOW FOR R-32 REFRIGERANT INSTALLATIONS

NOTES: 1. Applies to fixed ducted systems with continuous air-flow or refrigerant detection systems only.
2. Based on LFL of 0.306 kg/m³