

B/S/H-02/03 Series: Vertical Wall Mount Installation – Models w/DX Cooling and Electric or Hydronic (Hot Water) Heating

LIST OF SECTIONS - USERS INFORMATION MANUAL

1 – General.....	1	4 – Startup and Shutdown Instructions.....	5
2 – Safety.....	2	5 – Owner Maintenance.....	6
3 – Owner’s Information and Seasonal Information.....	3		

LIST OF SECTIONS -SERVICE AND MAINTENANCE MANUAL

1 – Safety.....	8	7 – Special Piping Instructions For A2L Class Flammable Refrigerant .	22
2 – Air Handler Maintenance	12	8 – Refrigerant Leak Detection System Operation and Sensor Replacement.	22
3 – Air Handler Controls.....	13	9 – Field Installed Accessories.....	24
4 – Sequence of Operation	16	10 – Replacement Parts.....	25
5 – Troubleshooting	17	11 – Decommissioning & Disposal of the Air Handler	29
6 – Blower Performance	21		

LIST OF FIGURES

1 – Visual Check Points – B/S-02/03 / Electric Heat.....	4	13 – Electric Heater Contactor – B/S-02/03.....	14
2 – Visual Check Points – H-02/03 / Hydronic Heat	4	14 – Refrigerant Leak Detection Sensor Location	14
3 – Front Panel Circuit Breaker Location – B-02/03.....	5	15 – Hydronic Heat Control Box – H-02/03	14
4 – Homeowner / User Cleaning Points – B/S-02/03 / Electric Heat	6	16 – Component Locations – H-02/03 / Hydronic Heat	15
5 – Homeowner / User Cleaning Points – H-02/03 / Hydronic Heat	6	17 – Hydronic Control Board – H-02/03	15
6 – Internal Air Filter Location - B/S-02/03 / Electric Heat.....	7	18 – Constant Torque Motor Terminals.....	19
7 – Internal Air Filter Location - H-02/03 / Hydronic Heat.....	7	19 – Blower Assembly.....	20
8 – Typical 1” Replacement Air Filter	7	20 – Replacement Parts Schematic – B/S-02 / Electric Heat	25
9 – Blower Assembly	13	21 – Replacement Parts Schematic – B/S-03 / Electric Heat	26
10 – No Electric Heat Control Box – B/S-02/03.....	13	22 - Replacement Parts Schematic - H-02 / Hydronic Heat.....	27
11 – Electric Heat Control Box – B/S-02/03.....	13	23 - Replacement Parts Schematic - H-03 / Hydronic Heat	28
12 – Component Locations – B/S-02/03 / Electric Heat.....	14		

LIST OF TABLES

1 – Constant Torque Motor Terminal Descriptions – B/S-02/03/Elect Heat ..	19	6 – Replacement Parts List – B/S-02 / Electric Heat.....	25
2 – Constant Torque Motor Terminal Descriptions – H-02/03/Hyd Heat.....	19	7 – Replacement Parts List – B/S-03 / Electric Heat.....	26
3 – Blower Motor FLA.....	19	8 - Replacement Parts List - H-02 / Hydronic Heat	27
4 – Blower Performance Chart – Without Air Filters.....	21	9 - Replacement Parts List - H-03 / Hydronic Heat	28
5 – Field Installed Accessory List.....	24		

CONTACT INFORMATION

Manufactured and Distributed by:

Mortex Products Inc
501 Terminal Rd
Fort Worth, TX 76106

www.mortx.com

SECTION 1: GENERAL

The following list includes important facts and information regarding this air handler.

1. Models with electric heat and no heat are rated for 208/240 VAC, 60 Hz, 1-Phase.
2. Models with hydronic heat are rated for 115 VAC, 60 Hz, 1-Phase.
3. Air handler is designed for both cooling only and heat pump applications.
4. Models are available in small, medium, or large cabinet size.
5. Air handler is designed for upflow applications only.
6. Air handler must not be operated without the access panel installed.
7. Air handler is listed by ETL for the United States and Canada.

INSTALLERS MUST READ ALL INSTRUCTIONS IN THIS MANUAL

THIS MANUAL MUST BE SAVED BY THE HOMEOWNER OR USER FOR FUTURE REFERENCE.



This is a safety alert symbol. When you see this symbol on labels or in manuals, be alert to the potential for personal injury. Understand and pay particular attention to the signal words **DANGER**, **WARNING**, or **CAUTION**.

DANGER: Indicates an imminently hazardous situation, which if not avoided, **will result in death or serious injury**.

WARNING: Indicates a potentially hazardous situation, which if not avoided, **could result in death or serious injury**.

CAUTION: Indicates a potentially hazardous situation, which if not avoided, **may result in minor or moderate injury**. It is also used to alert against unsafe practices and hazards involving property damage.

WARNING

FIRE OR ELECTRICAL HAZARD

Failure to follow the safety warnings exactly could result in serious injury, death, or property damage.

A fire or electrical hazard may result causing property damage, personal injury or loss of life.

Do not store or use gasoline or other flammable vapors and liquids in the vicinity of this air handler or any other appliance.

WARNING

Any adjustment, service or maintenance by the homeowner and/or user may create a condition where the operation of the product could cause personal injury or property damage.

Only qualified service personnel, a contractor, or an installer may refer to the service and maintenance section of this manual for assistance or for additional service or repair information on this air handler.

CAUTION

This product requires periodic routine maintenance and cleaning of the exterior surfaces by the homeowner or user to remove dust and debris. Any additional service must be performed by qualified personnel. This air handler must be serviced and maintained as specified in these instructions and/or to any applicable local, state, and national codes including, but not limited to building, electrical, and mechanical codes.

DANGER

Do not use this air handler if any part has been under water. A flood damaged air handler is extremely dangerous. Attempts to use the air handler can result in a fire.

A qualified contractor, installer, or service agency must be contacted to inspect the air handler for any water damage and replace all components, control system parts, or electrical parts that have been damaged. If enough damage is present, the air handler may need to be replaced.

WARNING

RISK OF FIRE

This unit is equipped with a refrigerant leak detection system for safety and with electrically powered safety measures. To be effective, the unit must be electrically powered at all times after installation, other than when servicing.

Safety Requirements

1. This air handler must be kept clear and free of combustible materials, gasoline and other flammable vapors and liquids.
2. Never store flammable materials of any kind near this air handler. Gasoline, solvents and other volatile liquids should be stored only in approved containers outside the home. These materials vaporize easily and are extremely dangerous.
3. Refer to the dimensions page of these instructions to determine the proper location to install the air handler.
4. Follow the instructions exactly as shown in **Section 4: Startup and Shutdown Instructions** in this manual to properly start up or shut down this air handler.
5. If overheating occurs, turn the power off to the air handler and contact a qualified contractor, installer, or service agency.
6. Never store cleaning materials such as bleaches, detergents, powder cleaners, etc. near the air handler. These chemicals can cause corrosion of the air handler sheet metal and the electric heaters, the blower and the electrical controls.
7. Never use the area around the air handler as a storage area for items which could block or obstruct air-flow the space around the air handler. This flow of air is required for safe and proper operation. Never block or obstruct air openings used for ventilation and cooling of the air handler electrical components.
8. Refer to the air handler rating plate for requirements for safe operation.
9. Provide clearance for service access to the control box, electric heat elements or hydronic coil, and blower.
10. Failure to carefully read and follow all instructions in this manual can result in malfunction of the air handler, death, personal injury, and/or property damage.
11. If the air handler is installed in a residential garage, it must be installed so that the electric heaters are located no less than 18 inches above the floor and the air handler must be located or protected to avoid physical damage by vehicles.
12. These instructions cover minimum requirements and conform to existing national standards and safety codes. In some cases, these instructions exceed certain local codes and ordinances,

especially those who have not kept up with changing modular home and residential home construction practices. These instructions are to be followed and are the minimum requirement to perform service or repairs on this air handler.

13. Installation, servicing and maintenance must only be performed by qualified service personnel that are licensed by the state to install, service, and repair HVAC equipment and those who have successfully completed a course in handling, installing, commissioning, maintenance, servicing, repairing, decommissioning, and disposal of equipment using a flammable refrigerant offered by an accredited national training organization or the manufacturer of the equipment.
14. This air handler is for use at elevations of 10,000 ft (3,048m) or less.
15. This air handler is not to be used by persons (including children) with reduced physical, sensory or mental capabilities, or lack of experience and knowledge, unless they have been given supervision or instruction concerning use of this air handler by a person responsible for their safety. Children must not be allowed to play with this air handler.

WARNING

Do not use Methanol water or Ethanol in any systems operating above 40°F as the flash point specified for these chemicals is only 54°F.

WARNING

Minimum Allowable Operating Temperatures – Water/Brine:
Water = 36°F (2.22°C)
Brine Solution = 3.2°F (-16°C)
Maximum Allowable Operating Temperatures – Water/Brine:
Water = 180°F (82.22°C)
Brine Solution = 40°F (4.44°C)

WARNING

FIRE OR ELECTRICAL HAZARD

Servicing heating/cooling equipment can be hazardous due to electrical components.

Only trained and qualified personnel can service or repair heating/cooling equipment. The homeowner must never try to perform service, repair or maintenance on this air handler.

Untrained service personnel can perform only basic maintenance functions such as cleaning of exterior surfaces and replacing the air filters only!

Observe all precautions in the manuals and on the attached labels when working on this air handler.

SECTION 3: OWNERS INFORMATION AND SEASONAL INFORMATION

HOW THE AIR HANDLER WORKS

Heating Cycle - Electric Heat Models

When the thermostat calls for heat on the electric heat models, the heater contactor is energized, sending 208/240 VAC through to the electric heaters causing them to heat up. The indoor fan motor is

then energized on the selected heating speed tap after an “ON” time delay which causes the circulating blower to draw air from the living space, passes it across the heater coils, and circulates the warmed air through the duct system to the living space. When the thermostat is satisfied, the electric heaters are de-energized and the blower is de-energized after an “OFF” time delay. The heating cycle has ended and the air handler is now in the stand-by mode awaiting the next call for heat.

Heating Cycle - Hydronic Heat Models

When the thermostat calls for heat on the hydronic heat models, a pump relay will be energized causing a flow of hot water through the hot water coil which heats the coil. The indoor fan motor is energized on the heating speed tap after an “ON” time delay which causes the circulating blower to draw air from the living space, passes it across the hot water coil, and circulates the warmed air through the duct system to the living space. When the thermostat is satisfied, the circulating pump is de-energized and the blower is de-energized after an “OFF” time delay. The heating cycle has ended and the air handler is now in the stand-by mode awaiting the next call for heat.

Cooling Cycle – Electric and Hydronic Heat Models

When the thermostat calls for cooling operation, 24 VAC is sent to the compressor contactor coil causing it to close which energizes the compressor and outdoor fan motor. The indoor fan motor is also energized on the selected cooling speed tap which causes the circulating blower to draw air from the living space, passes it across the cooling coil in the air handler, and circulates the cooled air through the duct system to the living space. When the thermostat is satisfied, the compressor contactor is de-energized which turns off the compressor and outdoor fan motor. The blower is de-energized after an “OFF” time delay. The cooling cycle has ended and the air handler is now in the stand-by mode awaiting the next call for cooling.

Heat Pump Heating Cycle – Electric and Hydronic Heat Models

When the thermostat calls for heat pump heating operation, 24 VAC is sent to the compressor contactor causing it to close which energizes the compressor and outdoor fan motor. If not already in the heating position from a previous heating cycle, the reversing valve in the outdoor unit switches position causing the flow of the refrigerant to reverse and heat the coil inside the air handler. The indoor fan motor is energized on the selected heat pump heating speed tap which causes the circulating blower to draw air from the living space, passes it across the coil in the air handler, and circulates the warmed air through the duct system to the living space. When the thermostat is satisfied, the compressor contactor is de-energized which turns off the compressor and outdoor fan motor. The blower is also de-energized after an “OFF” time delay. The heat pump heating cycle has ended and the air handler is now in the stand-by mode awaiting the next call for heat pump heating.

EXAMINATION OF THE AIR HANDLER

The homeowner should perform a visual examine the air handler every month for any defects or problems. The items to be inspected are:

1. The physical support of the air handler is sound without sagging cracks, gaps, etc. around the base to provide a seal between the support and the base.
2. The air handler casing for any signs of deterioration from rust or corrosion.
3. The return and supply duct connections are physically sound

and are sealed to the air handler casing.

4. The air handler must be serviced by qualified personnel annually, preferably at the start of each heating season.

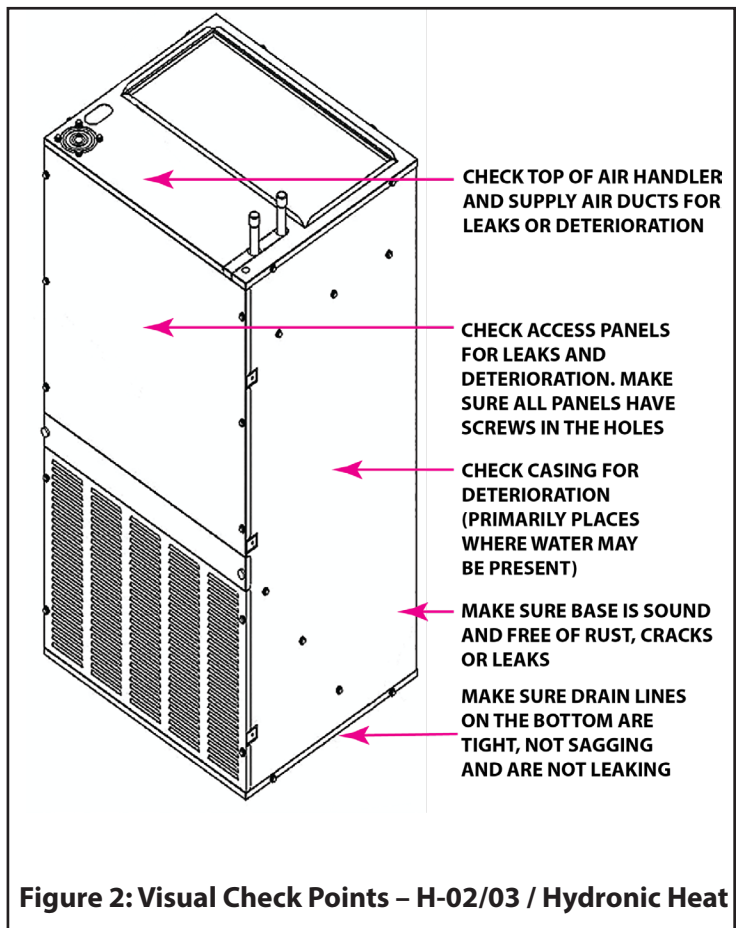
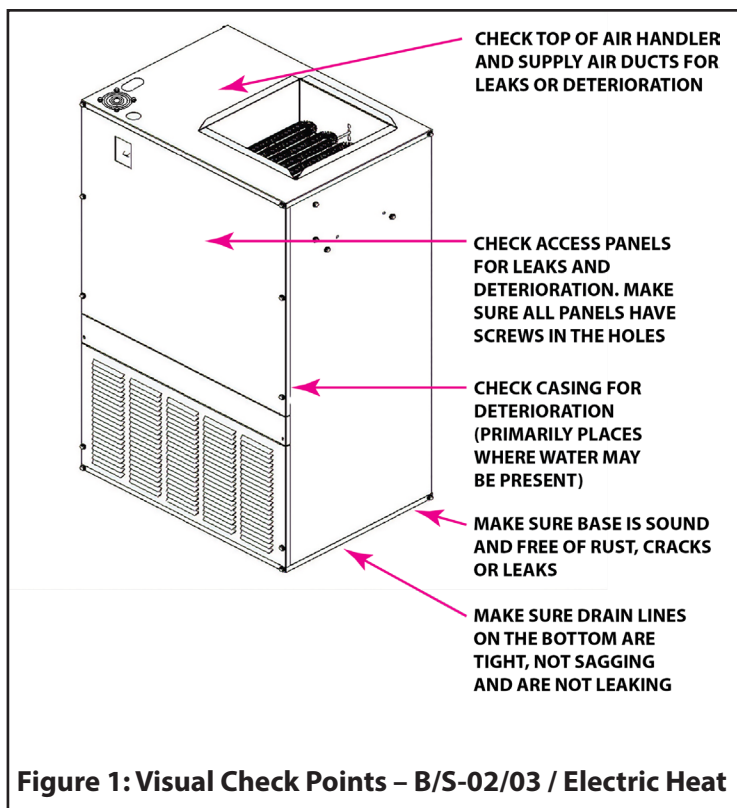

THE SERVICE TECHNICIAN

If the air handler gives any indication of improper operation, the homeowner or user should call a qualified service technician. The service technician is qualified to perform the normal routine care of the air handler and can detect potential problems and make corrections before trouble develops. Preventative maintenance of this type will allow the air handler to operate with minimal concerns to the homeowner and will add years of comfort. The homeowner or user must not attempt to service or repair this air handler except for the cleaning and filter maintenance tasks presented in **“Section 5: Owner Maintenance”** of this **User Information Manual**.

WARRANTY AND RESPONSIBILITIES

It is the sole responsibility of the homeowner to make certain the air handler has been properly installed and adjusted to operate properly. The manufacturer warrants the air handler to be free from defects in material or workmanship for a stated time in the warranty agreement. The manufacturer will not be responsible for any repair costs to correct problems due to improper setup, improper installation, improper adjustments, installing parts or components on the air handler that are not listed for use with this air handler, improper operating conditions, or repairs performed by the air handler user or homeowner.

Some specific examples of service calls which will be excluded from warranty reimbursement are:

1. Correcting faulty duct system in the home. This can be due to not enough ducts or ducts that are too small to provide proper air-flow through the air handler.
2. Correcting electrical wiring problems in the supply wiring to the air handler.
3. Resetting circuit breakers or on/off switches used for servicing.
4. Problems caused by installation and operation of any outdoor unit or air quality devices which are not approved for use with this air handler.
5. Improper thermostat settings or calibrating the thermostat.
6. Problems caused by construction debris which has fallen into the air handler.
7. Replacement of fuses.
8. Insufficient air-flow problems caused by dirty air filters.
9. Air handler malfunction or component premature failure caused by restrictions in the return or supply ducts causing low air-flow.

The homeowner should establish a clear understanding of these responsibilities with the installer and /or service company so there will be no misunderstanding of what will be covered under warranty later.

WHILE HOMEOWNER OR USER IS AWAY

The air handler is equipped with safety shutoff devices which are designed to prevent it from overheating in case of a malfunction. For this reason, it is never practical to assume the air handler will operate unattended for a long period of time. Examples of a malfunction that can cause significant damage to the home would be:

1. The air handler blower motor fails and the heater elements cycle on the safety shutoff devices while the temperature inside the home continues to drop. Water pipes will freeze and could burst once their temperature falls below 32°F resulting in significant damage to the structure.
2. The air handler blower motor or outdoor unit fails in the summer resulting in the temperature inside the home to rise above the setpoint. If the temperature of the home rises above the rated temperature of appliances, appliance failure can occur.
3. If the homeowner to be away from home for a long period of time, they should have someone check on the home every day, especially when the outside temperatures will be below 35°F

above 75°F to ensure the air handler is operating properly. This will help prevent water pipes from freezing or appliances from failing.

THE AIR HANDLER FAILS TO OPERATE PROPERLY

If any abnormalities are observed while the air handler is operating normally, perform the following checks:

1. Check the setting on the thermostat to make sure the thermostat is set above the room temperature.
2. Check to see if the electrical power is turned on at the circuit breakers at the main service circuit breaker box or check any on/off switches that may be used for service disconnect switches, especially ON/OFF switches used for servicing the air handler. These are often mistaken for light switches and are turned off.
3. Check any inline fuses that may have been installed on the air handler to determine if one has blown.
4. Make sure the air filters are clean, return grilles clean, are not obstructed, and supply air registers are open.

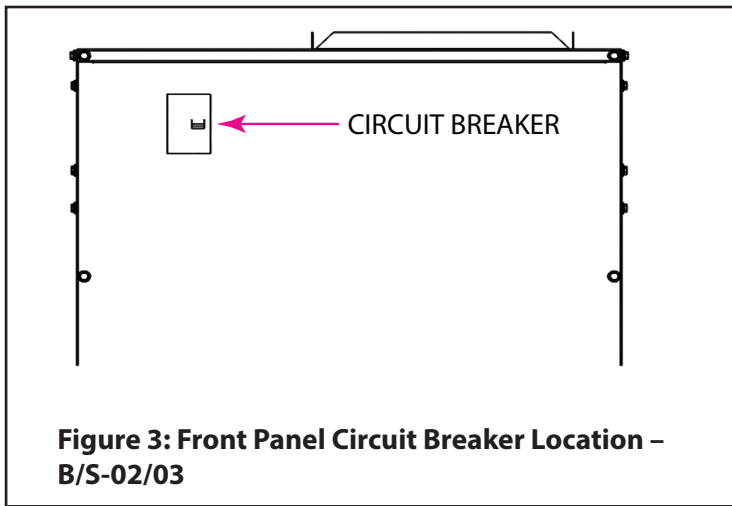

Figure 3: Front Panel Circuit Breaker Location – B/S-02/03

! WARNING

AIR HANDLERS WITH ELECTRIC HEATERS

Should overheating occur, turn the circuit breaker on the front of the air handler (if so equipped) to the OFF position and turn circuit breaker(s) in the main electrical panel (circuit breaker box) to the OFF position. Call qualified service personnel to troubleshoot and repair the air handler. Do not allow the air handler to continue to cycle on the limit.

WHEN TO CALL FOR SERVICE ASSISTANCE

Very often time can be saved if the homeowner provides the service agency the information about the air handler ahead of time. This will enable the service agency to determine the specific components used and possibly identify the problem, allowing them to arrive with the correct parts to fix the problem. Write down the model number, serial number and be prepared to describe what the air handler is or is not doing and what has already been checked prior to calling the service agency.

SERVICE AGENCY INFORMATION

Fill in Below

MODEL NUMBER: _____

SERIAL NUMBER: _____

SERVICE COMPANY: _____

ADDRESS: _____

TELEPHONE (DAYTIME): _____

TELEPHONE (EMERGENCY) _____

NOTES: _____

SECTION 4: STARTUP AND SHUTDOWN INSTRUCTIONS

! WARNING

Failure to follow the instructions below exactly may result in a fire causing property damage, personal injury, and/or loss of life.

Read the instructions below before trying to start the air handler.

- A. **BEFORE OPERATING:** Check around perimeter of the air handler to make sure there are no flammable materials in the area. If vapors of any kind are smelled, do not turn on the power to the air handler until vapors have been ventilated and removed from the area of the air handler.
2. **CHECK THE AIR HANDLER:** Visually check the air handler for loose screws and/or panels that may be missing or have fallen off.
3. **CHECK DUCT CONNECTIONS:** Visually check the connections of the ducts to the air handler to make sure there are no gaps or holes and ducts are securely fastened to the air handler.

TURNING ON / STARTING THE AIR HANDLER

1. **STOP!** Read the safety information above before proceeding.
2. Set the thermostat mode to the “OFF” setting.
3. Turn the circuit breakers for the air handler in the main electrical panel to the “ON” position.
4. If the air handler is equipped with a circuit breaker located on the front panel, switch it to the ON position (See Figure 3).
5. Turn the service disconnect switch near the air handler (if one is present) to the “ON” position.
6. Set the thermostat to the desired mode and temperature.

Shutting Down / Turning Off the Air Handler

1. Set the thermostat mode to the “OFF” mode.
2. If the air handler is operating at the time the thermostat is turned to the OFF position, wait until the air handler has completed its cycle and has shut down before turning off the power to the air handle.
3. Turn the circuit breaker(s) for the air handler in the main electrical panel to the “OFF” position.
4. If the air handler is equipped with a circuit breaker located on the front panel, switch it to the OFF position (See Figure 3).
5. Turn the service disconnect switch near the air handler (if one is present) to the “OFF” position.

SECTION 5: OWNER MAINTENANCE

All appliances need annual maintenance in order to operate properly. The annual service must be performed by qualified service personnel. The homeowner is expected to perform general cleaning of the exterior surfaces and replacement of the air filters. Air filters must be checked every month and replaced as needed. Figures 6 and 7 show the location of the air handler internal air filter.

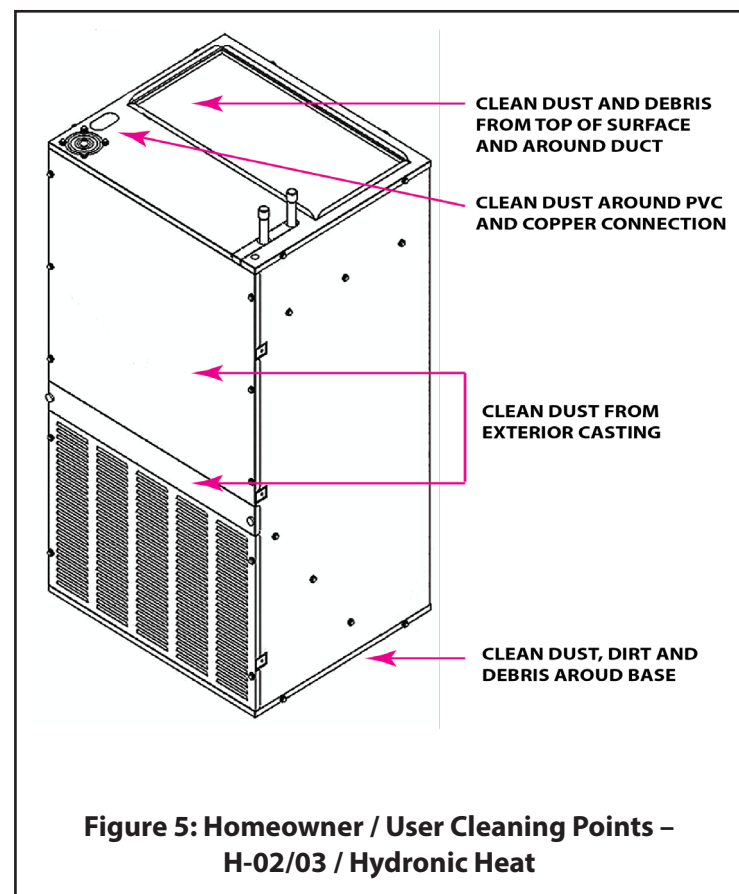
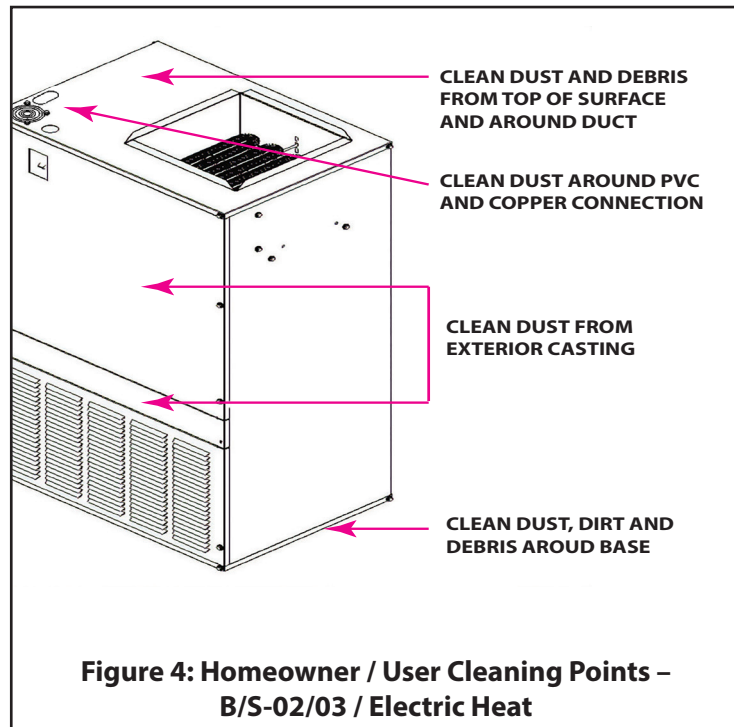

Internal Air Filter Replacement

Follow these easy steps to replace the air filters.

1. Follow the procedure **“To Turn Off the Air Handler”** in **Section 4: Startup and Shutdown Instructions** in this manual.
2. Unscrew the white thumb screws that secure the filter cover panel to the air handler and remove the filter cover panel.
3. Slide the air filter up and out of the filter track. The air filter is a disposable filter. Do not attempt to clean the filter and reuse it.
4. Clean any access dirt or debris around the front area where the air filter is located.
5. Check the size of the air filter that was removed and make sure it is replaced with the same size filter.
6. Slide the new air filter into the filter track, place the filter cover panel into place, and tighten the thumb screws.
7. **NOTE:** Make sure the flow arrow on the air filter is pointing towards the coil.
8. Follow the **“Turn On / Start the Air Handler”** in **Section 4: Startup and Shutdown Instructions** in this manual.

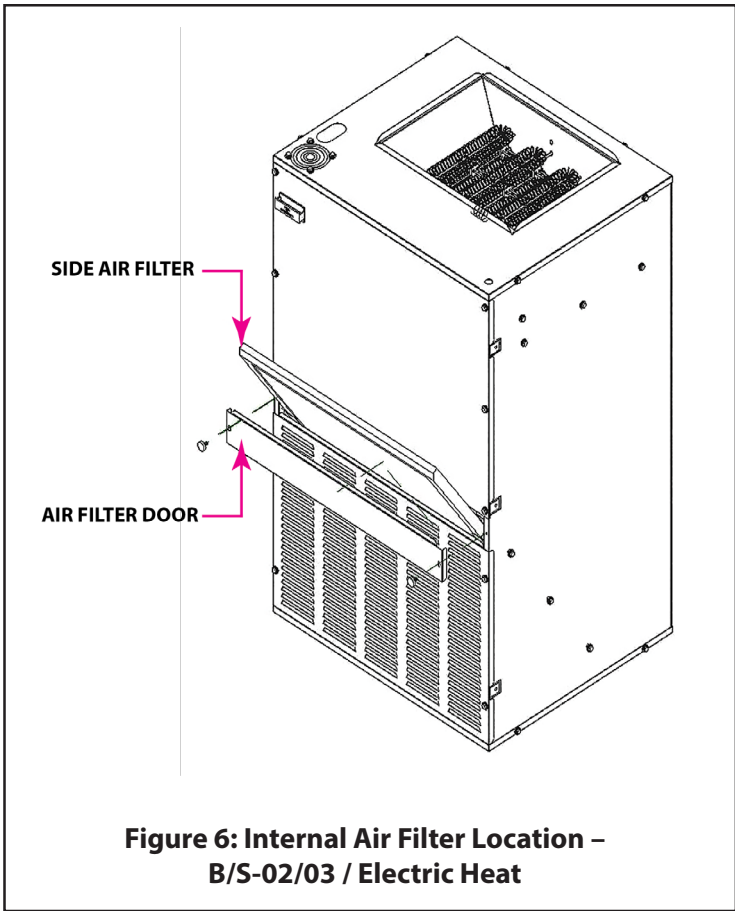

Figure 6: Internal Air Filter Location – B/S-02/03 / Electric Heat

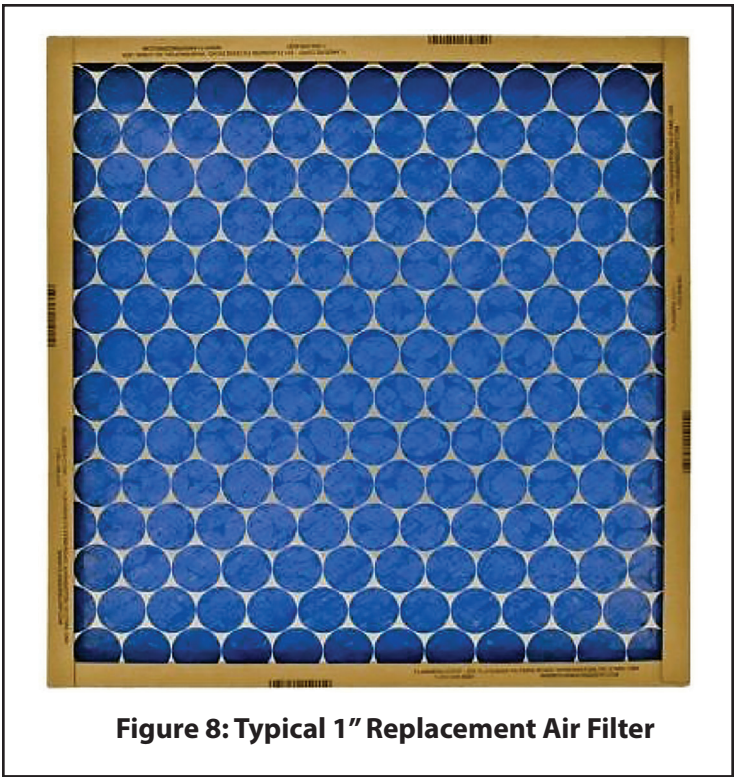

Figure 8: Typical 1" Replacement Air Filter

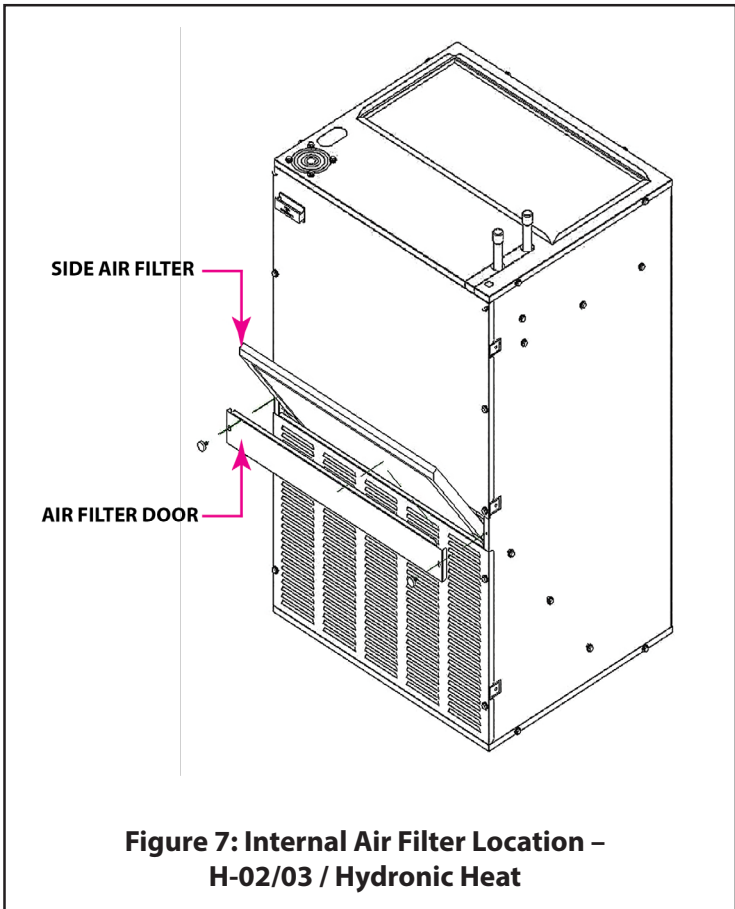

Figure 7: Internal Air Filter Location – H-02/03 / Hydronic Heat

SERVICE AND MAINTENANCE MANUAL

SECTION 1: SAFETY

THE HOMEOWNERS AND AIR HANDLER USERS MUST STOP HERE!

This section has been designed to assist a qualified service agency in performing service and maintenance on this air handler. The homeowner and/or the air handler user must never attempt to perform any service or maintenance on the air handler, especially when it involves the removal or adjustment of any parts and/or components.

WARNING

The manufacturer and distributor will not be responsible for any repairs due to removal of parts or improper parts changes, improper maintenance, improper adjustments or improper modifications to this air handler that were performed by the homeowner or the air handler user.

The manufacturer will not be responsible if the homeowner or air handler user uses this section of the instructions to perform maintenance or repairs to the air handler. This practice is very dangerous and may result in a fire causing property damage, personal injury, loss of life and/or will void the air handler warranty.



This is a safety alert symbol. When you see this symbol on labels or in manuals, be alert to the potential for personal injury. Understand and pay particular attention to the signal words **DANGER**, **WARNING**, or **CAUTION**.

DANGER: Indicates an imminently hazardous situation, which if not avoided, **will result in death or serious injury**.

WARNING: Indicates a potentially hazardous situation, which if not avoided, **could result in death or serious injury**.

CAUTION: Indicates a potentially hazardous situation, which if not avoided, **may result in minor or moderate injury**. It is also used to alert against unsafe practices and hazards involving property damage.

SAFETY REQUIREMENTS

1. Air handlers with electric heaters may have a dual electrical supply circuit. Check each electrical circuit with a meter to be sure the power has been disconnected before servicing.
2. Insulating materials may be combustible. The air handler must be kept free and clear of insulating materials.
3. Follow the instructions exactly as shown in **Section 4: Startup and Shutdown Instructions** in this manual to properly start up or shut down this air handler.
4. Make sure all moving parts have come to a complete stop before attempting to perform any work once the air handler access panels have been removed. Moving parts can cause serious injury if clothing or body parts get caught in the moving part.
5. Repair and maintenance to electrical components shall include initial safety checks and component inspection procedures. If a fault exists that could compromise safety, then no electrical supply shall be connected to the circuit until it is satisfactorily dealt with. If the fault cannot be corrected immediately but it is necessary to continue operation, an adequate temporary

WARNING

Improper adjustment, service or maintenance may create a condition where the operation of the product could cause personal injury or property damage.

Refer to this manual for assistance or for additional information consult the Technical Support Group.

CAUTION

This product must be serviced and maintained as specified in these instructions and/or to any applicable local, state, and national codes including, but not limited to building, electrical, and mechanical codes.

WARNING

FIRE OR ELECTRICAL HAZARD

Failure to follow the safety warnings exactly could result in serious injury, death, or property damage.

A fire or electrical hazard may result causing property damage, personal injury or loss of life.

WARNING

ELECTRICAL SHOCK, FIRE HAZARD

Failure to follow the safety warnings or improper servicing could result in dangerous operation, serious injury, property damage, and/or death.

- Before servicing this air handler, disconnect all electrical power to the air handler by turning the circuit breaker(s) in the main electrical panel (breaker box) to the OFF position and switching the circuit breaker (if so equipped) on the front panel or service disconnect switch to the OFF position.
- When servicing controls, label all wires prior to disconnecting to aid in proper reconnection of wires.
- Verify proper operation after servicing by turning the thermostat above the room temperature for a brief periods of time to ensure proper air handler operation.

solution shall be used. This shall be reported to the owner of the equipment so all parties are advised.

6. Initial safety checks shall include:
 - that capacitors are discharged: this shall be done in a safe manner to avoid possibility of sparking;
 - that no live electrical components and wiring are exposed while charging, recovering or purging the system;
 - that there is continuity of earth bonding.
7. Check that cabling will not be subject to wear, corrosion, excessive pressure, vibration, sharp edges or any other adverse environmental effects. The check shall also take into account the effects of aging or continual vibration from sources such as compressors or fans.

8. Installation, servicing and maintenance must only be performed by qualified service personnel that are licensed by the state to install, commission, service, repair, decommission, and dispose of HVAC equipment and those who have successfully completed a course in handling, installing, maintenance, servicing, and repairing equipment using a flammable refrigerant offered by an accredited national training organization or the manufacturer of the equipment.
9. Sealed electrical components must be replaced when they fail.
10. Intrinsically safe components must be replaced when they fail.

Maximum Operating Temperature for Heat Pump Applications

For heat pump applications, the maximum outdoor temperature recommended by the manufacturer while the system is operating in the heating mode is 70°F/23.9°C.

Proper Safe Working Procedures for Equipment Using Flammable Refrigerants

Prior to beginning work on systems containing flammable refrigerants, safety checks are necessary to ensure that the risk of ignition is minimized. For repair to the refrigerating system, the following steps must be completed prior to conducting work on the system.

1. Work shall be undertaken under a controlled procedure so as to minimize the risk of a flammable gas or vapour being present while the work is being performed.
2. All maintenance staff and others working in the local area shall be instructed on the nature of work being performed. Work in confined spaces shall be avoided.
3. The area shall be checked with an appropriate refrigerant detector prior to and during work, to ensure the technician is aware of potentially toxic or flammable atmospheres. Ensure that the leak detection equipment being used is suitable for use with all applicable refrigerants (i.e.: non-sparking, adequately sealed or intrinsically safe).
4. If any hot work is to be conducted on the refrigerating equipment or any associated parts, appropriate fire extinguishing equipment shall be available to hand. Have a dry powder or CO₂ fire extinguisher adjacent to the charging area.
5. No person performing work in relation to a refrigerating system which involves exposing any pipe work shall use any sources of ignition in such a manner that it may lead to the risk of fire or explosion. All possible ignition sources, including cigarette smoking, should be kept sufficiently far away from the site of installation, repairing, removing and disposal, during which refrigerant can possibly be released to the surrounding space. is to be surveyed to make sure that there are no flammable hazards or ignition risks. "No Smoking" signs shall be displayed.
6. Ensure that the area is in the open or that it is adequately ventilated before breaking into the system or conducting any hot work. A degree of ventilation shall continue during the period that the work is performed. The ventilation should safely disperse any released refrigerant and preferably expel it externally into the atmosphere.
7. Where electrical components are being changed, they shall be fit for the purpose and to the correct specification. At all times the manufacturer's maintenance and service guidelines shall be followed. If in doubt, consult the manufacturer's technical department for assistance.

Sealed electrical components that have failed must be replaced instead of being repaired.

Intrinsically safe components that have failed must be replaced instead of being repaired.

The use of dropped ceilings for return air is not permitted for this air handler.

8. The following checks shall be applied to installations using flammable refrigerants:
 - the actual refrigerant charge is in accordance with the room size within which the refrigerant containing parts are installed;
 - marking to the equipment continues to be visible and legible. Markings and signs that are illegible shall be corrected;
 - refrigerating pipe or components are installed in a position where they are unlikely to be exposed to any substance which may corrode refrigerant containing components, unless the components are constructed of materials which are inherently resistant to being corroded or are suitably protected against being so corroded.

9. Detection of Flammable Refrigerants

Under no circumstances shall potential sources of ignition be used in the searching for or detection of refrigerant leaks. A halide torch (or any other detector using a naked flame) shall not be used.

The following leak detection methods are deemed acceptable for all refrigerant systems.

Electronic leak detectors may be used to detect refrigerant leaks but, in the case of flammable refrigerants, the sensitivity may not be adequate, or may need re-calibration. (Detection equipment shall be calibrated in a refrigerant-free area.)

Ensure that the detector is not a potential source of ignition and is suitable for the refrigerant used.

Leak detection equipment shall be set at a percentage of the LFL of the refrigerant and shall be calibrated to the refrigerant employed, and the appropriate percentage of gas (25 % maximum) is confirmed.

Leak detection fluids are also suitable for use with most refrigerants, but the use of detergents containing chlorine shall be avoided as the chlorine may react with the refrigerant and corrode the copper pipe-work.

NOTE: Examples of leak detection fluids are:

- bubble method,
- fluorescent method agents.

If a leak is suspected, all naked flames shall be removed/ extinguished.

If a leakage of refrigerant is found which requires brazing, all of the refrigerant shall be recovered from the system, or isolated (by means of shut off valves) in a part of the system remote from the leak. Removal of refrigerant shall be according to Step 10 below.

10. Removal and Evacuation

When breaking into the refrigerant circuit to make repairs or for any other purpose, conventional procedures shall be used. However, for flammable refrigerants, it is important that best practice be followed since flammability is a consideration. The following procedure shall be adhered to:

- safely remove refrigerant charge following local and national regulations;

- evacuate;
- purge the circuit with inert gas (optional for A2L);
- evacuate (optional for A2L);
- continuously flush or purge with inert gas when using flame to open circuit; and
- open the circuit.

The refrigerant charge shall be recovered into the correct recovery cylinders if venting is not allowed by local and national codes. For appliances containing flammable refrigerants, the system shall be purged with oxygen-free nitrogen to render the appliance safe for flammable refrigerants. This process might need to be repeated several times. Compressed air or oxygen shall not be used for purging refrigerant systems. (Also see **Refrigerant Recovery Requirement** below.

For appliances containing flammable refrigerants, purging shall be achieved by breaking the vacuum in the system with oxygen-free nitrogen and continuing to fill until the working pressure is achieved, then venting to atmosphere, and finally pulling down to a vacuum (optional for A2L). This process shall be repeated until no refrigerant is within the system (optional for A2L). When the final oxygen-free nitrogen charge is used, the system shall be vented down to atmospheric pressure to enable work to take place.

The outlet for the vacuum pump shall not be close to any potential ignition sources, and ventilation shall be available.

11. **Charging Procedures**

In addition to conventional charging procedures, the following requirements shall be followed.

- Ensure that contamination of different refrigerants does not occur when using charging equipment. Hoses or lines shall be as short as possible to minimize the amount of refrigerant contained in them.
- Cylinders shall be kept in an appropriate position according to the instructions.
- Ensure that the refrigerating system is earthed prior to charging the system with refrigerant.
- Label the system when charging is complete (if not already).
- Extreme care shall be taken not to overfill the refrigerating system.

Prior to recharging the system, it shall be pressure-tested with the appropriate purging gas. The system shall be leak-tested on completion of charging but prior to commissioning. A follow up leak test shall be performed prior to leaving the site.

12. **Refrigerant Recovery Requirements**

When removing refrigerant from a system, either for servicing or decommissioning, it is recommended good practice that all refrigerants are removed safely.

When transferring refrigerant into cylinders, ensure that only appropriate refrigerant recovery cylinders are employed. Ensure that the correct number of cylinders for holding the total system charge is available. All cylinders to be used are designated for the recovered refrigerant and labeled for that refrigerant (i.e: special cylinders for the recovery of refrigerant). Cylinders shall be complete with pressure-relief valve and associated shut-off valves in good working order. Empty recovery cylinders are evacuated and, if possible, cooled before recovery occurs.

The recovery equipment shall be in good working order with

a set of instructions concerning the equipment that is at hand and shall be suitable for the recovery of the flammable refrigerant. If in doubt, the manufacturer should be consulted. In addition, a set of calibrated weighing scales shall be available and in good working order. Hoses shall be complete with leak-free disconnect couplings and in good condition.

The recovered refrigerant shall be processed according to local legislation in the correct recovery cylinder, and the relevant waste transfer note arranged. Do not mix refrigerants in recovery units and especially not in cylinders.

If compressors or compressor oils are to be removed, ensure that they have been evacuated to an acceptable level to make certain that flammable refrigerant does not remain within the lubricant. The compressor body shall not be heated by an open flame or other ignition sources to accelerate this process. When oil is drained from a system, it shall be performed safely.

13. **Commissioning of the System**

- Ensure that the floor area is sufficient for the refrigerant charge or that the ventilation duct is assembled in a correct manner.
- Connect the pipes and perform a leak test before charging with refrigerant.
- Check safety equipment before putting into service.

14. **Maintenance of the Air Handler**

- Ensure sufficient ventilation at the repair place.
- Be aware that malfunction of the equipment may be caused by refrigerant loss and a refrigerant leak is possible.
- Discharge capacitors in a way that won't cause any spark. The standard procedure to short circuit the capacitor terminals usually creates sparks.
- Reassemble sealed enclosures accurately. If seals are worn, replace them.
- Check safety equipment before putting the air handler into service.

15. **Repair of the Air Handler**

- Ensure sufficient ventilation at the repair place.
- Be aware that malfunction of the equipment may be caused by refrigerant loss and a refrigerant leak is possible.
- Discharge capacitors in a way that won't cause any spark.
- When brazing is required, the following procedures shall be performed in the following order:
 - Safely remove the refrigerant following local and national regulations. If the recovery is not required by national regulations, drain the refrigerant to the outside. Take care that the drained refrigerant will not cause any danger. In doubt, one person should guard the outlet. Take special care that drained refrigerant will not float back into the building;
 - Purge the refrigerant circuit with oxygen free nitrogen;
 - Evacuate the refrigerant circuit;
 - Remove parts to be replaced by cutting or brazing.
 - Purge the braze point with nitrogen during the brazing procedure required for repair.
 - Perform a leak test before charging with refrigerant.
- Reassemble sealed enclosures accurately. If seals are worn, replace them.
- Check safety equipment before putting the system back into service.

16. **Decommissioning of the Air Handler (Refer to Section 11**

of this manual for additional information)

- If the safety is affected when the equipment is put out of service, the refrigerant charge shall be removed before decommissioning.
- Ensure sufficient ventilation at the equipment location.
- Be aware that malfunction of the equipment may be caused by refrigerant loss and a refrigerant leak is possible.
- Remove the refrigerant. If the recovery is not required by national regulations, drain the refrigerant to the outside. Take care that the drained refrigerant will not cause any danger. In doubt, one person should guard the outlet. Take special care that drained refrigerant will not float back into the building.

17. Disposal of the Air Handler (Refer to Section 11 of this manual for additional information)

- Ensure sufficient ventilation at the working place.
- Remove the refrigerant. If the recovery is not required by national regulations, drain the refrigerant to the outside. Take care that the drained refrigerant will not cause any danger. In doubt, one person should guard the outlet. Take special care that drained refrigerant will not float back into the building.
- When flammable refrigerants are used,
 - evacuate the refrigerant circuit.
 - purge the refrigerant circuit with oxygen free nitrogen.

 **WARNING**

FIRE HAZARD

For air handlers using A2L refrigerants connected via an air duct system to one or more rooms with a floor area less than shown in Tables 18 and 19 in the Installation Instructions for this air handler, those rooms shall be without continuously operating open flames (e.g.: an operating gas appliance) or other potential ignition sources (e.g.: an operating electric heater, hot surfaces). A flame-producing device may be installed in the same space if the device is provided with an effective flame arrest

 **WARNING**

FIRE HAZARD

For air handlers using A2L refrigerants connected via an air duct system to one or more rooms, only auxiliary devices approved by the air handler manufacturer or declared suitable with the refrigerant shall be installed in connecting ductwork.

 **WARNING**

RISK OF FIRE – FLAMMABLE REFRIGERANT APPLICATIONS
If any refrigerating circuit contains more than 62.6 oz (1.776 kg) of R-454B refrigerant or more than 64.6 oz (1.836 kg) of R-32 refrigerant, an unventilated area where the air-handler using a flammable refrigerant is installed shall be so constructed that should any refrigerant leak, it will not stagnate and create a fire or explosion hazard.

If the air duct system connected to one or more rooms with an area less than the minimum conditioned space floor area shown in “Minimum Conditioned Space and Airflow Tables” (Tables 18 and 19) found in the installation instructions for this air handler based on the total system refrigerant charge, that room shall be without continuously operating open flames (e.g.: an operating gas appliance) or other potential ignition sources (e.g.: an operating electric heater, hot surfaces). A flame-producing device may be installed in the same space if the device is provided with an effective flame arrest.

 **WARNING**

RISK OF FIRE – FLAMMABLE REFRIGERANT APPLICATIONS
The ductwork connected to this air-handler shall not contain an ignition source.

Auxiliary devices which may be a potential ignition source shall not be installed in the duct work. Examples of such potential ignition sources are hot surfaces with a temperature exceeding 1292°F (700°C and electric switching devices.

Only auxiliary devices approved by the air-handler manufacturer or declared suitable with the refrigerant shall be installed in connecting ductwork.

 **WARNING**



RISK OF FIRE

Do not use means to accelerate the defrosting process or to clean, other than those recommended by the manufacturer.

The appliance shall be stored in a room without continuously operating ignition sources (e.g.: open flames, an operating gas appliance, or an operating electric heater.

Do not pierce or burn.

Be aware that refrigerants may not contain an odor.



WARNING

FIRE HAZARD

NEVER CONNECT A JUMPER BETWEEN THE "R" & "W" THERMOSTAT WIRES

Placing jumper wire between the RED and WHITE thermostat wires at the air handler in order to override the thermostat and energize the heater elements is an extremely dangerous practice that can result in damage to the thermostat, dangerous operation, serious injury, property damage and/or death.

SECTION 2: AIR HANDLER MAINTENANCE

The interior sections of the air handler must be cleaned and adjusted by a qualified service contractor once a year or before the start of each heating or cooling season. The following items must be checked:

1. The blower wheel and motor for excessive dirt.
2. The electric heaters for wear, damage or corrosion.
3. The electrical components for excessive dust, dirt, wear, or deterioration.
4. The supply air duct system for excessive dust, dirt or debris.
5. The return air duct system for excessive dust, dirt or debris.
6. All electrical wiring for wear, insulation cracks and/or damage.
7. Check the indoor coil for dust, debris or damage.
8. Check the indoor coil drain pan for proper drainage to prevent water backup into the air handler.
9. The air handler casing and all interior sheet metal panels or dividers.

Air Handler Cleaning Procedure

1. Follow the instructions exactly as shown in the Startup and Shutdown Section in the Users Information Manual section of this manual to properly shut down the air handler.

WARNING: Electrical power must be disconnected to the air handler before performing this procedure!

2. Remove the blower/control box access panel on the front of the air handler.
3. Unscrew the white thumb screws that secure the air filter cover panel to the air handler and remove the filter cover panel and filter.
4. Disconnect the blower motor wiring harness plug from the mating plug located under the right side of the control box.
5. Place a piece of cardboard (or equivalent) on top of the coil to prevent dirt or debris from falling onto the coil and to protect the coil while removing and reinstalling the blower assembly.
6. Remove the 2 screws that attach the blower assembly to the blower deck that are located under the control box on each side of the blower.
7. Remove only the 4 screws (2 on each side) nearest the front of the air handler that attach the filter channels to side of the cabinet. These are located on the outside of the air handler cabinet.

NOTE: Do not remove the 2 screws (1 screw on each side) nearest the rear of the air handler as this will make re-attaching the filter channels more difficult.

NOTE: If sides of air handler are not accessible in a wall mount installation, it will need to be detached from the wall and supply

duct and then pulled out of the wall enough to remove the filter channel screws.

8. Remove the 2 screws that attach the top of the coil assembly to the sides of the air handler cabinet.
9. While supporting the coil, push the top of the filter rack channels inward to clear the air handler cabinet and allow the top of the coil to drop enough for the blower housing to clear the top of the coil assembly.

NOTE: Take care not to damage the refrigerant tubing when lowering the coil assembly.

10. Slide the blower assembly out of the air handler.
11. Check the blower motor for dust and debris. Be sure to clean the openings on the motor housing as these openings are used to cool the motor. If the dust, dirt or debris has not been removed from these openings, the motor could run hotter than normal which could shorten the life of the motor.
12. Check the blower wheel for dust and debris. Use the brush and the vacuum cleaner to remove any dust or debris from the wheel. Be careful not to move or accidentally remove the blower wheel balance weight(s) located on the wheel blade. Moving or removing a balance weight will cause the blower wheel to vibrate. If the blower wheel is vibrating, it must be replaced.
13. Check in the area above the blower where the heater elements or hydronic heating coil are located and remove any dust, dirt or debris from around the heater elements. Be careful not to damage the heater elements with the vacuum hose or the brush.
14. Use a vacuum cleaner and a small brush to remove any dirt and debris from the blower and indoor coil compartments.
15. Check the indoor coil condensate drain pan for any debris and ensure the drain pan is properly draining by pouring water into the drain pan.
16. Remove any excess water that may have spilled from checking the indoor coil condensate drain.
17. Check and clean any dust in the supply and return ducts with the brush and vacuum cleaner as far as can be reached. If the ducts look like they have an excessive amount of dust, dirt or debris, recommend to the homeowner or user to call a professional to properly clean the duct system.
18. Check and clean any dust, dirt, or debris from all controls and all surfaces in the control box. If dust or dirt is left on the components, they could operate at a much hotter temperature than normal causing premature component failure.
19. Slide the blower mount plate (See Figure 9) into the track under the blower deck until it stops and install the 2 screws that attach the blower assembly to the blower deck that were removed in Step 6.
20. Lift the top of the coil assembly and install the 2 screws that attach the top of the coil assembly to the air handler cabinet.
21. **NOTE:** Take care not to damage the refrigerant tubing when raising the coil assembly into place.
22. Lift the filter channels until they clear the front of the cabinet and push them outward until they are against the cabinet insulation. Install the 4 screws that attach them to the sides of the cabinet.
23. Re-attach the air handler to the wall and supply duct if applicable.
24. Connect the blower motor wiring harness plug into the mating plug located under the right side of the control box.
25. Remove the cardboard from above the coil.

26. Slide the air filter into the filter rack and install the filter cover panel.

NOTE: Make sure the filter flow arrows point toward the coil.

27. Install the blower/control box access panel.

28. Follow the instructions as shown in **Section 4: Startup and Shutdown** section in the **Users Information Manual** section of this manual to properly start up the air handler.

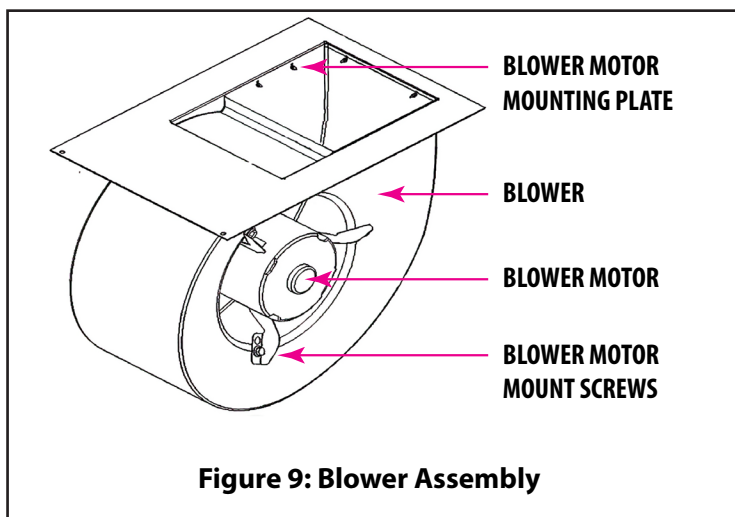

Figure 9: Blower Assembly

SECTION 3: AIR HANDLER CONTROLS

ELECTRIC HEAT AND NO HEAT MODELS

This section discusses the air handler controls and how they operate. Refer to Figures 10 and 11 for component locations.

Limit Control(s) – Each electric heater element has an overtemperature limit control directly in front of it to sense overheating of the element. The limit electrical contacts open if the temperature rises above the set point of the limit control and interrupts the 24 VAC signal to the heater contactor coil which de-energizes the heater element. When the temperature of the element cools sufficiently for the limit control to reset, the heater elements are re-energized and the heater cycles until the cause for the overheating is corrected.

In addition to the automatic reset limit switch, each heating element has a non-resettable (one-shot) limit switch that will interrupt 208/240 VAC to the heating element should the automatic reset limit switch fail to function properly in an over temperature situation

Heater Contactor(s) – The electric heater contactor turns the heater elements on and off. The contactor is controlled by the thermostat. On a call for heat by the thermostat, 24 VAC is applied to the 24 VAC coil of the contactor causing the electrical contacts of the contactor to close which energizes the heater elements.

Transformer – The transformer is used to reduce line voltage from 208 – 240 VAC to 24 VAC. The transformer provides the required 24 VAC for the system control circuit.

Circuit Breakers – The circuit breakers are designed as over-current protection for the air handler internal electrical components. Field wiring must be protected by field supplied circuit breakers or fuses sized to protect the wire connected to the air handler circuit breakers.

Refrigerant Leak Detection System – A refrigerant leak sensor is located on a bracket attached to the right coil endplate under the blower. Should a refrigerant leak occur in the coil itself or tubing, the sensor will detect the leak and energize the indoor blower and disable the outdoor unit compressor. The leak detection system consists of a single device that houses a refrigerant sensor and internal relays. Refer to Figure 14 for the location of the refrigerant leak sensor.

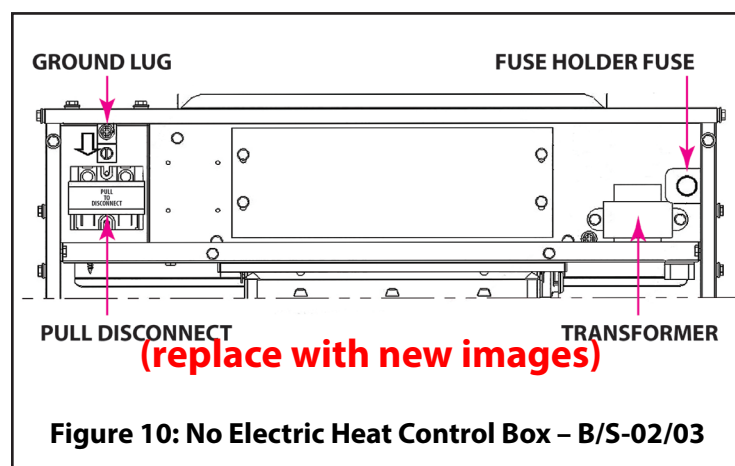

Figure 10: No Electric Heat Control Box – B/S-02/03

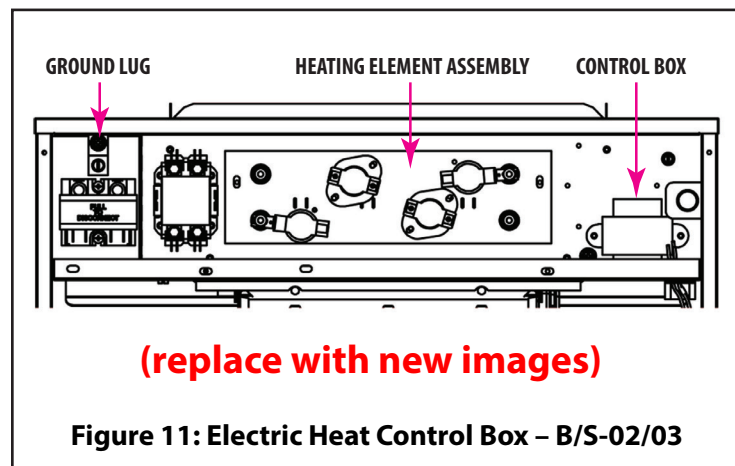
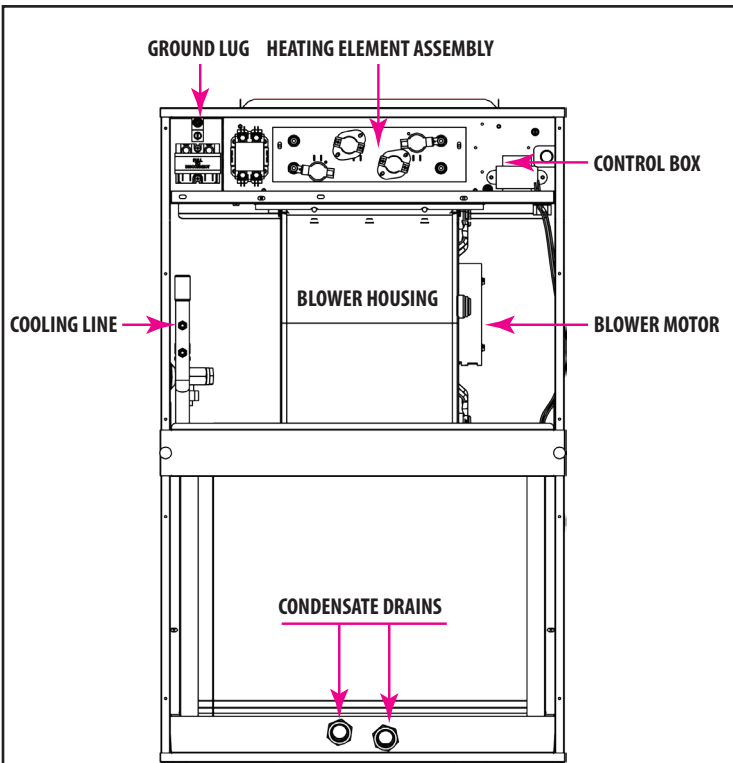
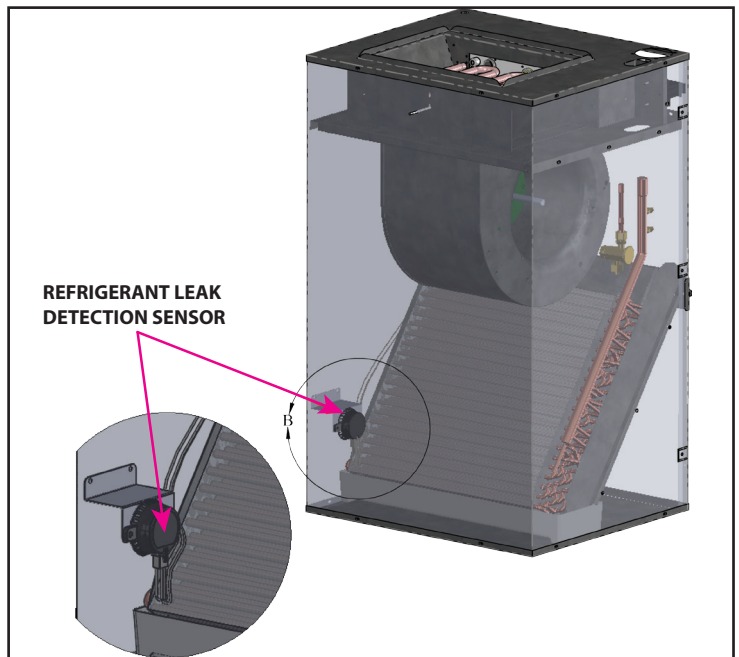

Figure 11: Electric Heat Control Box – B/S-02/03



(replace with new images)

Figure 12: Component Locations – B/S-02/03 / Electric Heat



(replace with new images)

Figure 14: Refrigerant Leak Detection Sensor Location

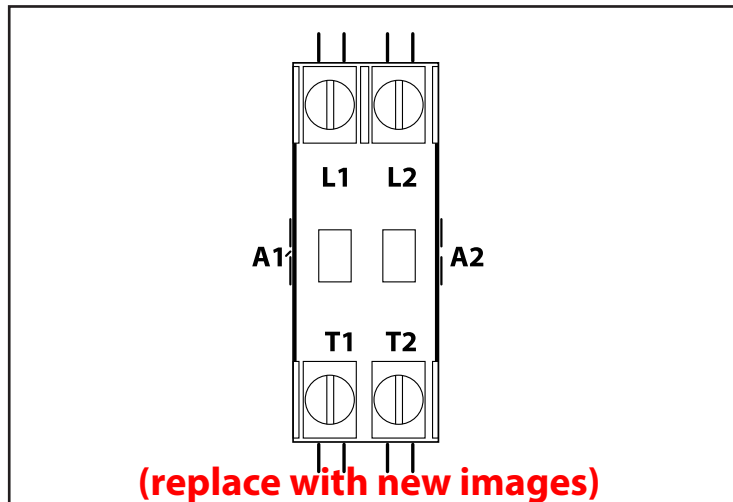

(replace with new images)

Figure 13: Electric Heater Contactor – B/S-02/03

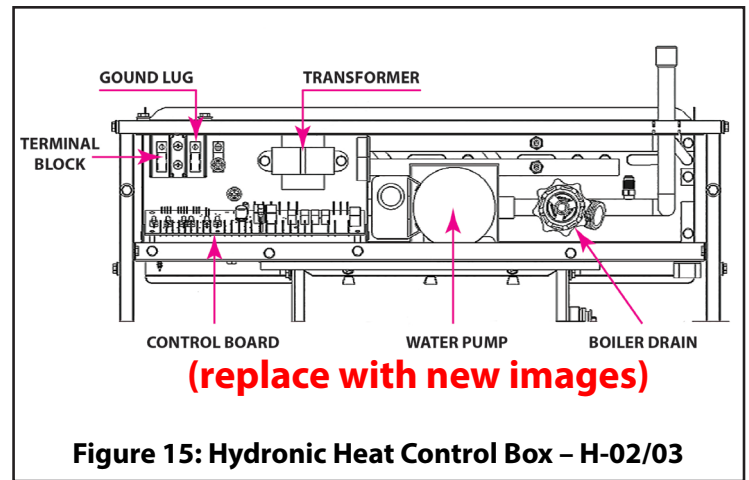

(replace with new images)

Figure 15: Hydronic Heat Control Box – H-02/03

AQ – The aquastat switch is placed on the hot water line exiting side of the air handler coil. The aquastat is connected to the R terminal and the AQ terminal on the control board. The AQ jumper pin shown in Figure 17 must be in the ON position to use this feature. When there is a call for heat (24 VAC on the W terminal) and the water line temperature reaches the aquastat switch setting, the switch will close sending 24 VAC to the AQ terminal turning on the blower motor. The blower motor will not energize until the aquastat switch is closed. When the call for heat has been satisfied, the indoor blower will be de-energized after the selected OFF delay.

VALVE – There are two terminals used to power a 24VAC zone valve or solenoid valve. The terminal closest to the 24V COM terminals is a 24VAC common terminal to the valve. See Figure 17. The other terminal is the 24 VAC output to the valve. When there are 24 VAC to the W terminal the control board will send 24 VAC to the valve terminals. The VALVE terminals de-energize when the 24 VAC is removed from the W terminal.

BOILER - There are two terminals that are connected to a switch. The terminals do not output any voltage and are dry contacts. The BOILER switch is designed to be connected to the “T” terminals on a boiler aquastat to energize the boiler when the control board has a call for heat (24 VAC on W).

G – When 24 VAC is placed on the G terminal the control will energize the indoor blower by the FAN CIR terminal with NO delay. When the 24 VAC signal has been removed from the G terminal, the indoor blower will be de-energized with NO delay.

If there is a call for heat (24 VAC on the W terminal) while 24 VAC is present on the G terminal, the control will energize the pump, valve and boiler and the indoor fan motor will be de-energized. The indoor fan motor will be energized by the LOW terminal after the selected ON delay. When the call for heat has been satisfied, the control will de-energize the valve, pump and boiler and the indoor fan motor will switch to the FAN CIR speed terminal after the selected OFF delay.

If there is a call for cooling while there is 24 VAC on the G terminal, the control will switch the indoor blower speed to the HI terminal. When the call for cooling has been satisfied, the control will switch the indoor blower back to the FAN CIR speed.

W – When 24 VAC is present on the W terminal, the control will energize the pump, valve and boiler and the indoor fan will be energized by the LOW terminal after the selected ON delay. When the call for heat has been satisfied, the control will de-energize the valve, pump and boiler and the indoor fan motor will be de-energized after the selected OFF delay.

FR – The FR terminal energizes the control board freeze protection. The freeze protection switch is secured to the water coil. The two white wires are connected to the R terminal and to the FR terminal on the control board. When the temperature of the coil is below 38°F, the freeze protection switch closes and sends 24VAC to the FR terminal. The control will energize the pump, valve, boiler and indoor fan motor on the LOW speed terminal. The control will not energize the indoor fan motor even when there is a call for heat with 24 VAC on the W terminal. When the water temperature has risen above 42°F, the freeze protection switch will open. The control will de-energize the pump, valve, boiler, and the LOW speed terminal providing there is not a call for heat. If there is a call for heat at the time FR is de-energized, the pump, valve, and boiler will remain ON and the control will keep the LOW speed terminal energized.

W2/RH – When W2/RH is energized, the control will de-energize the LOW speed terminal and will energize the MED speed terminal with no delay. When the W2 Terminal is de-energized the MED speed terminal will be de-energized and the LOW speed terminal will be energized with no delay.

BY – Bypass terminal is used when the heating and domestic hot water system are managed with the same tankless hot water system. The domestic water line has a normally open flow switch that is connected to the R and the BY terminals on the control board. When the domestic water flow switch detects the flow of water, the switch closes sending 24 VAC to the BY terminal. The control will de-energize the PUMP, VALVE, BOILER terminals and the indoor blower. When the domestic water flow has stopped the domestic water flow switch will open and the PUMP, VALVE, and BOILER terminals will resume normal operation. The indoor blower will be energized after the selected ON delay. The domestic water flow switch will open and the PUMP, VALVE, and BOILER terminals will resume normal operation. The indoor blower will be energized after the selected ON delay.

Y – When there is a call for cooling (24 VAC is placed on the Y terminal), the control will energize the indoor blower with the HI terminal after the selected ON delay. When the call for cooling has been satisfied, the indoor blower will be de-energized after the selected OFF delay.

DHM – **IMPORTANT NOTE:** H-02/03 air handlers are not set up for cooling mode dehumidification. Connecting a humidistat to

SECTION 4: SEQUENCE OF OPERATION

Continuous Blower – Electric Heat Models

The thermostat has a manual fan switch that can be moved to the “ON” position for continuous fan position. This setting causes the thermostat to complete the circuit between “R” and “G” thermostat terminals. This sends 24 VAC to the selected indoor blower motor speed tap for the continuous fan mode (RED motor speed tap wire). The indoor blower will operate continuously until the fan switch on the thermostat is switched from “ON” to the “AUTO” setting which will cause the constant torque blower motor to be de-energized after a 30 second OFF time delay that is programmed into the motor’s control module.

Continuous Blower – Hydronic Heat Models

The thermostat has a manual fan switch that can be moved to the “ON” position for continuous fan operation. This causes the thermostat to complete the circuit between “R” and “G” thermostat terminals sending 24 VAC to the “G” terminal on the hydronic control board. The hydronic control board will then energize the “FAN CIR” terminal which sends 24 VAC to the selected indoor blower motor speed tap for the continuous fan mode (BLUE motor speed tap wire). The indoor blower will operate continuously until the fan switch on the thermostat is switched from “ON” to the “AUTO” setting. When the thermostat is switched back to “AUTO”, the blower motor motor’s control module.

Intermittent Blower – Cooling - Electric Heat Models

The thermostat has a manual fan switch that can be moved to the “AUTO” position for intermittent fan operation. When the thermostat calls for cooling on models with constant torque motors, the circuit is completed between the “R”, “Y” and “G” terminals causing the motor to operate on the selected speed

tap for the cooling mode (BLACK motor speed tap wire). When the thermostat is satisfied, the circuit between "R", "Y" and "G" will open, the blower motor will shut down after a 30 second OFF delay which is programmed into the motor control module.

Intermittent Blower – Cooling - Hydronic Heat Models

The thermostat has a manual fan switch that can be moved to the "AUTO" position for intermittent fan operation. When the thermostat calls for cooling, the circuit is completed between the "R", "Y" and "G" terminals sending 24 VAC to the hydronic control board through the "Y" and "G" terminals. The blower motor will be energized on the selected cooling speed (BLACK motor speed tap wire) through the "HI" terminal on the control board after the selected ON time delay. When the thermostat is satisfied, the circuit between "R", "Y" and "G" opens. The hydronic control board will de-energize the "HI" terminal on the control board after the selected OFF time delay on the hydronic control board and the blower motor will shut down. The blower is now in the stand-by mode awaiting the next cooling cycle.

Intermittent Blower - Heating - Electric Heat Models

When the thermostat is set to the HEAT mode and the fan switch on the thermostat is set to AUTO, the call for heat closes the thermostat circuit between the "R" and "W" terminals. 24 VAC is sent from the "W" terminal on the thermostat, through the white thermostat wire, the white pigtail wire on the air handler to the 24 VAC coil on the first heater contactor. This signal energizes the heater contactor, closing the contacts and sending 208 - 240 VAC to the heaters. The 24 VAC signal from the "W" thermostat terminal will also energize the motor's selected heating speed tap (RED motor speed tap wire). When the call for heat has ended, the "W" thermostat terminal is de-energized which will de-energize the motor and open the heater contactor contacts. The air handler is now in the stand-by mode awaiting the next heating cycle.

Intermittent Blower - Heating - Hydronic Heat Models

When the thermostat is in the HEAT mode and the fan switch on the thermostat is set to AUTO, a call for heat closes the thermostat circuit between the "R" and "W" terminals. 24 VAC is sent from the "W" terminal on the thermostat through the white thermostat wire that is connected to the "W" terminal on the air handler hydronic control board. The hydronic control board then energizes the water pump relay on the control board which sends 115 VAC to the PUMP terminal. This will energize the water pump and start the circulation of hot water through the water coil. The hydronic control board energizes the motor on the selected heating speed (RED motor speed tap wire) through the LOW speed terminal on the control board after the selected ON time delay. When the call for heat has ended, the "W" terminal is de-energized which opens the control board pump relay contacts shutting down the pump. The blower motor will shut down after the selected OFF time delay. The air handler is now in the stand-by mode awaiting the next heating cycle.



WARNING

For personal safety be sure to turn the electrical power "OFF" at the main entrance (Circuit Breaker Box) and at the control box circuit breakers before attempting any service or maintenance operations. Homeowners should never attempt to perform any maintenance which requires opening the air handler control box cover.



WARNING

To avoid personal injury, take precautions to not touch non-insulated electrical components.

Avoid wearing loose clothing or any items that can become caught in moving parts, such as the blower wheel. This can cause serious personal injury.

The following checks should be made before troubleshooting the air handler controls when the blower does not operate or there is a no-heat or no-cooling issue.

1. Check all circuit breakers in the air handler and at the building main electrical panel. Make sure they are turned to the "ON" position and have not tripped.
2. Check all fuses, especially any supply line fuses that were installed during installation, check the wiring with an OHM meter for a short to ground. If shorted, repair the short, and then replace the fuse.
3. Check any electrical switches that are external to the air handler to make sure they are turned on, especially ON/OFF switches used for servicing the air handler. The service switch is often mistaken for a light switch and is turned off.
4. Check all wiring connections, especially those on the components, to ensure they are securely fastened.

ELECTRIC HEAT MODELS

If the air handler is equipped with electric heaters, check to make sure there is 208 - 240 VAC between the terminals on the load side of the circuit breakers in the control box . If 208-240 VAC is not present, check to see if the circuit breaker(s) in the air handler control box or in the building breaker box are tripped. If 208-240 VAC is present on the load side of the circuit breaker in the control box, check to make sure there is 24 VAC between to the RED thermostat pigtail or "R" low voltage terminal block terminal and ground. If 24 VAC is not present, but there is 208-240 VAC on the load side of the circuit breaker, check to see if the in-line fuse connected to the transformer secondary circuit is blown. If the fuse is not blown, check the wiring and connections from the transformer to the low voltage terminal block or RED low voltage pigtail.

Constant Torque Motor Check – Electric Heat Models

If the blower motor will not run in both the heating and cooling modes and there is 208-230 VAC on the load side of the circuit breaker in the control box, check the connections in the blower motor 6-pin plugs (BMMP and BMFP). If those connections are OK, proceed with the following checks. If the motor is not running, check for 208 - 240 VAC between the L and N motor terminals and

for 24 VAC at either the RED or BLACK wires connecting to 2 of the motor terminals 1 - 5 when the thermostat is calling for blower operation. Refer to Figure 18 and Table 1 for terminal locations and definitions. If the 208 - 240 VAC is present between the L and N terminals and 24 VAC is measured between motor terminal C and one of the motor speed tap wires, but the motor is not operating, replace the motor. If 208 - 240 VAC is not present between the L and N motor terminals, check the 6wiring connections to the control board and circuit breaker. If 24 VAC is not present at any of the motor speed tap wires going to the motor terminal block terminals 1 – 5, check the connections to the control board and check to see if the in-line 3A fuse connected to the transformer secondary is blown.

Heating Mode – Electric Heat Models - Constant Torque Motor

If 24 VAC is not present between the “W” terminal on the air handler’s low voltage terminal block and ground when the thermostat is calling for heat, check the wiring and wiring connections from the thermostat “W” terminal to the “W” terminal on the air handler’s low voltage terminal block. If 24 VAC is present on the “W” terminal on the low voltage terminal block, check for 24 VAC on the RED motor speed tap wire connected to the motor terminal block. If 24 VAC is not present on the RED motor speed tap wire, check the wiring and wiring connections between the low voltage terminal block and the blower motor terminal block. If the wiring and connections are OK, replace the motor.

Cooling Mode or Continuous Fan - Electric Heat Models - Constant Torque Motor

If 24 VAC is not present between the “G” and “C” terminals on the air handler’s low voltage terminal block when there is a call for cooling or continuous fan operation, check for 24 VAC between the “R” and “C” terminals on the thermostat. If 24 VAC is not present at the thermostat “R” terminal, check the wiring from the “R” terminal on the air handler’s low voltage terminal block to the thermostat. If there is 24VAC at the thermostat “R” terminal, but not at the “G” terminal on the thermostat when there is a call for cooling or continuous fan operation, replace the thermostat. If there is 24 VAC between the “G” and “C” terminals on the air handler’s low voltage terminal block, check for 24 VAC on the BLACK motor speed tap wire connected to the motor terminal block. If 24 VAC is not present on the BLACK motor speed tap wire, check the wiring and wiring connections between the low voltage terminal block and the blower motor terminal block. If the wiring and connections are OK, replace the motor.

Heating Element Is Not Heating

Check for 208 - 240 VAC between terminals T1 and T2 of the heater contactor(s). If 208 - 240 VAC is present, check the resistance across the heating element terminals. If the heating element resistance is infinity (open circuit), replace the defective heating element.

If 208-240 VAC is not present between the T1 and T2 terminals (load) of a heater contactor, but 208-240 VAC is present between the terminals L1 and L2 (line) of the heater contactor(s) and there is 24 VAC across the coil of that contactor, replace the heater contactor.

If 24 VAC is not present across the heater contactor coil, use an ohmmeter to check for continuity across the terminals of all auto-reset limit controls on the heater element assembly. If the contacts on any limit control are open when the heating elements are cool, replace that limit control.

If 208-240 VAC is present between heater contactor terminals T1 and T2, but 208-240 VAC is not present between the heater element terminals, use an ohmmeter to check for continuity across the terminals of all non-resettable limit controls on the heater element assembly. If the contacts on any non-resettable limit control are open, replace that limit control.

HYDRONIC HEAT MODELS

Hydronic Control Board

Models with hydronic heat have a hydronic control board. There should be 115 VAC between the L1 and N terminals on the power terminal block or between pins #4 and #5 in the power cable plug at the motor, and 115 VAC between the XFMR and N/L2 terminals on the control board. There should also be 24 VAC between the “Rin” and “COM” terminals on the control board. Also check to make sure there is 24 VAC between the “R” terminal and “COM” terminal on the control board.

If there is 24 VAC between “Rin”, but 24 VAC is not present between the “R” and “COM” terminals, check the fuse on the control board to see if it is blown. If there is 24 VAC at both of these locations, continue the troubleshooting process by conducting the following checks.

Constant Torque Motor Check – Hydronic Heat Models

If the motor is not running when there is a call for heat, cooling, or continuous fan, check for 115 VAC between the L and N motor terminals and check for 24 VAC between the “COM/24V” terminal and either the “HI”, “MED”, or “LO” terminal on the control board. If 115 VAC is present between motor terminals L and N, and 24 VAC is present between the “COM/24V” terminal and either the “HI”, “MED” or “LO” terminal on the control board, but the motor is not operating, check the wiring connections at the motor terminals and the motor connector plugs BMMP and BMFP. If these connections are secure, replace the motor. Refer to Figure 18 and Tables 1 and 2 for terminal locations and definitions.

If there is 24 VAC between “Rin”, but 24 VAC is not present between the “R” and “COM” terminals, check the fuse on the control board to see if it is blown. If there is 24 VAC at both of these locations, continue the troubleshooting process by conducting the following checks.

Constant Torque Motor Check – Hydronic Heat Models

If the motor is not running when there is a call for heat, cooling, or continuous fan, check for 115 VAC between the L and N motor terminals and check for 24 VAC between the “COM/24V” terminal and either the “HI”, “MED”, or “LOW” terminal on the control board. If 115 VAC is present between motor terminals L and N, and 24 VAC is present between the “COM/24V” terminal and either the “HI”, “MED” or “LOW” terminal on the control board, but the motor is not operating, check the wiring connections at the motor terminals and the motor connector plugs BMMP and BMFP. If these connections are secure, replace the motor. Refer to Figure 18 and Tables 1 and 2 for terminal locations and definitions.

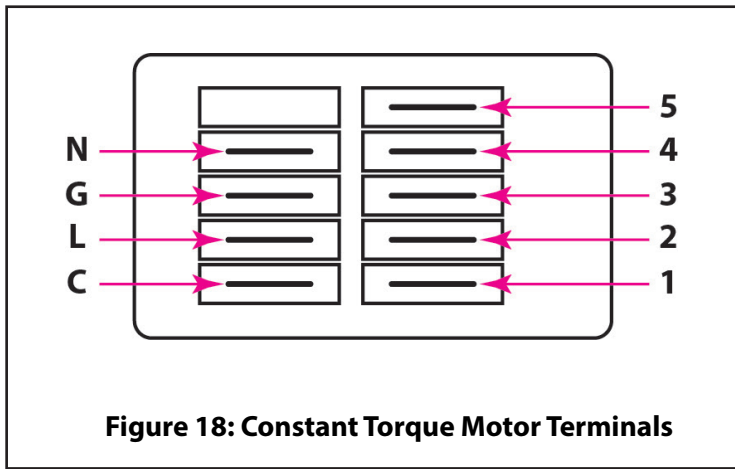

Figure 18: Constant Torque Motor Terminals

Terminal	Connection
C	Speed Tap Common - 24 VAC Common
L	Supply Voltage - 240 Vac Line 1
G	Ground Connection
N	Supply Voltage - 240 Vac Line 2
1	Low Speed Tap - 24 VAC Input
2	Medium-Low Speed Tap - 24 VAC Input
3	Medium Speed Tap - 24 VAC Input
4	Medium-High Speed Tap - 24 VAC Input
5	High Speed Tap - 24 VAC Input

Table 1: Constant Torque Motor Terminal Descriptions - B/S-02/03 / Electric Heat

Terminal	Connection
C	Speed Tap Common - 24 VAC Common
L	Supply Voltage - 115 VAC
G	Ground Connection
N	Supply Voltage - 240 Vac Line 2
1	Low Speed Tap - 24 VAC Input
2	Medium-Low Speed Tap - 24 VAC Input
3	Medium Speed Tap - 24 VAC Input
4	Medium-High Speed Tap - 24 VAC Input
5	High Speed Tap - 24 VAC Input

Table 2: Constant Torque Motor Terminal Descriptions - H-02/03 / Hydronic Heat

MODEL	HP	Voltage	FLA
B/S-02	1/3	208/240	1.7/1.6
B/S-03	1/2	208/240	2.5/2.4
H-02	1/3	115	2.4
H-03	1/2	115	3.2

Table 3: Blower Motor FLA

WARNING

To avoid personal injury, take precautions to not touch non-insulated electrical components.

Avoid wearing loose clothing or any items that can become caught in moving parts, such as the blower wheel. This can cause serious personal injury.

Replacing the Blower Motor

1. Follow the instructions as shown in **Section 4: Startup and Shutdown Instructions** in this manual to properly shut the air handler down.
2. Remove the upper access panel on the front of the air handler by removing the 10 screws that secure the panel to the casing then lifting it up and outward.
3. Remove the screws that fasten the control box cover to the control box.
4. Unplug the 9-pin plug underneath the right side of the control box.
5. Remove the 3 screws located under the control box that secure the blower assembly mounting plate to the heat deck.
6. Slide the blower deck out of the front of the air handler.
7. Loosen the set-screw on the blower wheel hub that secures the wheel to the motor shaft. If the blower wheel doesn't move freely on the motor shaft, push the blower wheel against the motor housing as far as it will go. Locate any burrs that are on the shaft and file the burrs until the shaft surface is smooth.
8. Note the orientation of the motor leads relative to the blower housing. Remove the 3 screws that secure the motor to the blower housing and remove the blower motor.
9. Note the orientation of the motor leads relative to the motor mount legs. Loosen the bolt that secures the belly band and motor mount arms to the motor housing and attach the belly band and motor mount arms to the new motor so the motor mount legs are in the same orientation as they were on the motor that was removed.
10. Slide the shaft of the new blower motor through the hub in the blower wheel until the mounts are resting on the blower housing.
11. Rotate the motor until the holes in the motor mount legs line up with the screw holes in the blower housing and the motor leads are oriented the same way as they were on the motor that was removed.
12. Slide the blower back into the air handler and install the 3 screws that secure the blower assembly mounting plate to the heat deck.
13. Set the blower wheel so it is positioned in the middle of the housing and tighten the set-screw on the flat side of the motor shaft.
14. Slide the blower back into the air handler and install the screws that secure the blower mounting plate to the blower deck.
15. Install the screws that secure the control box cover to the control box.
16. Plug the 9-pin plug into the mating plug underneath the right side of the control box.
17. Install the front access panel.
18. Follow the instructions as shown in **Section 4: Startup and Shutdown Instructions** in this manual to properly place the air handler back in operation.

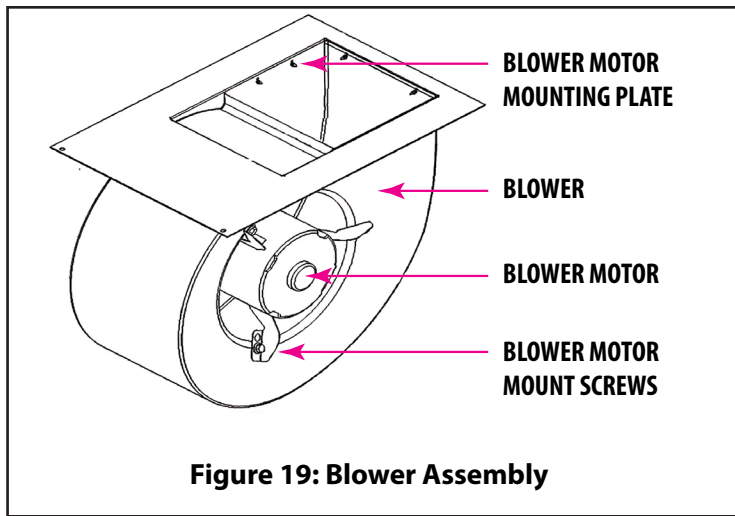

Figure 19: Blower Assembly

TXV TROUBLESHOOTING

The thermostatic expansion valve (TXV) is like the carburetor in a car engine. It opens and closes to allow the correct amount of refrigerant flow through the system. When the TXV isn't working properly, the capacity and efficiency of the system is reduced. If a faulty TXV is suspected, perform the following tests:

1. Connect refrigerant gauges to the system and check that the thermostatic expansion valve (TXV) is like the carburetor in a car engine. It opens and closes to allow the correct amount of refrigerant flow through the system. When the TXV isn't working properly, the capacity and efficiency of the system is reduced. If a faulty TXV is suspected, perform the following tests:
2. Connect refrigerant gauges to the system and check that the refrigerant pressures, liquid subcooling and suction superheat levels are correct according to the outdoor unit charging chart. Subcooling at the outdoor unit liquid service valve is normally around 10°F and superheat at the outdoor unit suction service valve is normally between 8 -12°F, but these can vary depending on the manufacturer and model of the outdoor unit.
3. Check to see if the indoor airflow through the system is correct. Check to see if the indoor and outdoor coils and indoor air filters are dirty. Clean dirty coils and clean/replace dirty air- filters as necessary before measuring air-flow and checking pressures, superheat, and subcooling.
4. Make sure the refrigerant charge in the system is correct. This step may require weighing the refrigerant in the system. Once refrigerant charge weight has been adjusted as necessary, recheck the refrigerant pressures, subcooling and superheat. If the pressures, subcooling and superheat are still not correct, the TXV may be defective or the TXV inlet strainer or the liquid line filter drier is plugged with debris.
5. A good way to determine if the TXV is defective is to remove the TXV's sensing bulb from the suction line and check the pressures, subcooling, superheat again. No change in the pressures, subcooling, and superheat levels is an indication the TXV is defective. Another test that can be performed is to place the sensing bulb in ice water and recheck the pressures, superheat, and subcooling levels. If these values do not change, the TXV is likely defective.

Additional TXV Troubleshooting Information Low Suction Pressure – High Superheat

POSSIBLE CAUSES:

1. Undersized TXV
2. TXV superheat adjustment too high

3. High indoor coil pressure drop due to internal restriction
4. TXV sensing bulb installed on bottom of suction line
5. Restricted or capped TXV external equalizer tube
6. Improper TXV external equalizer location (must be located on the suction manifold after the last feeder tube)
7. Low refrigerant charge
8. Plugged liquid line filter drier
9. Plugged TXV inlet strainer
10. Low outdoor ambient temperature

High Suction Pressure – Low Superheat

POSSIBLE CAUSES:

1. Oversized TXV
2. TXV seat leakage
3. TXV superheat adjustment too low
4. Improper TXV sensing bulb installation
 - a) Poor thermal contact with suction line (loose clamp)
 - b) Uninsulated sensing bulb
 - c) Warm location
1. Bad compressor (low capacity)
2. Incorrectly located external equalizer line (must be located on the suction manifold after the last feeder tube)

Low Suction Pressure – Low Superheat

POSSIBLE CAUSES:

1. Low system load:
 - a) Insufficient indoor airflow
 - b) Dirty indoor air filters
 - c) Return air too cold
 - d) Indoor coil icing or frosting
2. Poor air distribution over indoor coil
3. Improper indoor/outdoor coil internal volume balance (indoor coil too big or too small causing incorrect refrigerant charge balance between cooling and heating modes)
4. Oil trapped in indoor coil

Things to Check Before Replacing TXV

1. Slowly loosen the flare nut on the TXV external equalizer connected to the suction line port with a flare nut. If there is a large pressure release when the nut has been loosened, tighten the nut. If this results in a slight pressure release or no pressure release; the Schrader valve stem is not being depressed. Install an anti-blow back fitting to the external equalizer line of the TXV to depress the Schrader valve stem and check for proper operation of the TXV.
2. Remove the sensing bulb from the suction line and hold in a warm hand. The high side pressure should drop and low side pressure should increase as the TXV opens. Place the sensing bulb in ice water. The high side pressure should increase and the low side pressure should decrease as the TXV closes. If the pressures do not change when these tests are conducted, the TXV is faulty.

SECTION 6: BLOWER PERFORMANCE

Model Number	Motor HP	Volts	Motor Code	Blower Wheel	Speed Tap	CFM @ 0.10" ESP	CFM @ 0.20" ESP	CFM @ 0.30" ESP	CFM @ 0.40" ESP	CFM @ 0.50" ESP
B02, S02	1/3	208/240	XD	10 X 6	1	590	559	514	478	416
					2	635	605	564	531	508
					3	775	756	731	702	671
					4	946	932	912	892	863
					5	1011	987	981	962	943
B03, S03	1/2	208/240	XC	10 x 7	1	689	651	598	539	507
					2	747	693	656	607	564
					3	875	845	798	766	725
					4	1085	1058	1047	989	953
					5	1365	1340	1313	1268	1187
H02	1/3	115	XE	10 X 6	1	555	516	481	462	378
					2	616	581	555	516	499
					3	703	673	650	617	577
					4	787	760	748	711	673
					5	886	863	852	809	791
H03	1/2	115	XF	10 X 8	1	907	858	796	732	672
					2	1022	971	904	824	735
					3	1071	1011	953	878	800
					4	1152	1096	1040	966	888
					5	1296	1233	1170	1087	1000

Table 4: Blower Performance Chart – Without Air Filters

Minimum CFM for Electric Heat: 3kW = 195 CFM; 5kW = 325 CFM; 6kW = 390 CFM; 8kW = 520 CFM; 10kW = 650 CFM

SECTION 7: SPECIAL PIPING INSTRUCTIONS FOR A2L CLASS FLAMMABLE REFRIGERANT

WARNING

RISK OF FIRE

This following precautions must be taken for the refrigerant piping due to this air-handler being used with an A2L class flammable refrigerant.

Piping material, pipe routing, and installation shall, including protection from physical damage in operation and service, be in compliance with national and local codes and standards, such as ASHRAE 15, IAPMO Uniform Mechanical Code, ICC International Mechanical Code, or CSA B52 shall be observed. All field joints shall be accessible for inspection prior to being covered or enclosed.

Mechanical refrigerant connections must be made in accordance with the following procedure and shall be accessible for maintenance purposes.

The installation of pipe-work shall be kept to a minimum.

Due to this air-handler being used with an A2L class flammable refrigerant, the refrigerant pipe-work shall not be installed in an unventilated space, if that space is smaller than the minimum floor area shown in Tables 18 and 19 in the Installation Instructions Manual for this air handler unless there are no joints in the pipe-work in that space (e.g.: pipework that is run in walls or between floors).

Since refrigerant line length affects the final refrigerant charge, the final refrigerant charge after field charging of the system must be noted and used when determining the minimum floor area of the conditioned space from Tables 18 and 19 in the Installation Instructions Manual for this air handler.

Refrigerant Connections

For appliances using flammable refrigerants, all joints made in the installation between parts of the refrigerating system, with at least one part charged, shall be made in accordance with the following:

- A brazed, welded, or mechanical connection shall be made before opening the valves to permit refrigerant to flow between the refrigerating system parts. A vacuum valve shall be provided to evacuate the interconnecting pipe or any uncharged refrigerating system part.
- Mechanical connectors used indoors shall comply with ISO 14903 or UL 207 Annex A (USA only). When mechanical connectors are reused indoors, sealing parts shall be renewed. When flared joints are reused indoors, the flare part shall be refabricated.
- Refrigerant tubing shall be protected or enclosed to avoid damage.
- Flexible refrigerant connectors (such as connecting lines between the indoor and outdoor unit) that may be displaced during normal operation shall be protected against mechanical damage.

For installations with field applied joints that are exposed in the occupied space, these joints shall be at least one of the following:

- mechanical joints in compliance with ISO 14903 or or UL 207 Annex A (USA only)
- welded or brazed joints; or

- joints in enclosures that vent to the unit or to the outside. Provision shall be made for expansion and contraction of long runs of piping.

Protection devices, piping, and fittings shall be protected as far as possible against adverse environmental effects, for example, the danger of water collecting and freezing in relief pipes or the accumulation of dirt and debris.

Piping in refrigeration systems shall be so designed and installed to minimize the likelihood of hydraulic shock damaging the system. After completion of field piping for split systems, the field pipework shall be pressure tested with an inert gas and then vacuum tested prior to refrigerant charging, according to the following requirements:

- The minimum test pressure for the low side of the system shall be the low side design pressure and the minimum test pressure for the high side of the system shall be the high side design pressure, unless the high side of the system cannot be isolated from the low side of the system in which case the entire system shall be pressure tested to the low side design pressure.
- The test pressure after removal of pressure source shall be maintained for at least 1 hour with no decrease of pressure indicated by the test gauge, with test gauge resolution not During the evacuation test, after achieving a vacuum level specified in the manual or less, the refrigeration system shall be isolated from the vacuum pump and the pressure shall not rise above 1500 microns within 10 min. The vacuum pressure level shall be the lesser of 500 microns or the value required for compliance with national and local codes and standards, which may vary between residential, commercial, and industrial buildings.

Field made refrigerant joints indoors shall also be tightness tested after the system is charged with refrigerant. The test method shall have a sensitivity of 5 grams per year of refrigerant or better under a pressure of at least 0.25 times the maximum allowable pressure. No leak shall be detected.

SECTION 8: REFRIGERANT LEAK DETECTION SYSTEM OPERATION AND SENSOR REPLACEMENT

WARNING

This air handler is equipped with a refrigerant leak mitigation system that energizes the air handler blower motor to deliver at least the required minimum airflow (See Table 18 and 19 in the Installation Instructions for this air handler) when the refrigerant leak detection system detects a leak. This will dilute the flammable A2L class refrigerant to a point that it no longer poses a risk of an explosion or fire. Follow the procedure “Verifying Proper Functioning of Refrigerant Leak Mitigation System” later in this section to confirm the refrigerant mitigation system is functioning as it should.

This air handler is equipped with a refrigerant leak detection system consisting of a leak mitigation refrigerant sensor with integral relays. Should a refrigerant leak occur in the indoor coil, the refrigerant leak detection system will energize the indoor blower on the cooling mode speed tap and will open the 24VAC circuit to the outdoor unit compressor contactor. The circulation of air will disperse the leaked flammable refrigerant into the conditioned space where it will be diluted to point where it can no longer be ignited by an ignition source. This process is referred to as "Leak Mitigation". The indoor blower will continue to operate until 5 minutes after the concentration of the refrigerant at the sensor drops below the sensor's setpoint. Should the concentration of the refrigerant rise above the setpoint of the sensor, the mitigation cycle will repeat until the refrigerant concentration stays below the setpoint of the sensor. The sensor pigtail marked "ALARM" will normally be energized with 24VAC when no leak is detected and will be de-energized when a leak is detected for the purpose of notifying a building management system to issue a refrigerant leak alarm.

Should the sensor fail or if the wiring to the sensor is damaged or disconnected, the sensor will automatically enter the mitigation mode until the sensor is replaced or the wiring is reconnected or repaired.

IMPORTANT NOTE: The outdoor unit control wiring must be connected to the refrigerant sensor "Y-CC" pigtail and the "COM" on the air handler low voltage terminal strip for the refrigerant detection system to de-energize the compressor during the leak mitigation mode of operation.

Verifying Proper Functioning of Refrigerant Leak Mitigation System

A test to confirm the proper functioning of the refrigerant leak mitigation system must be performed at the final system check-out. Follow the procedure below to perform that test.

1. Remove the blower/control box access panel from the front of the air handler.
2. Locate the black refrigerant sensor located near the bottom right side of the coil assembly below the blower (See Figure 14).

Leak Detected During Cooling Cycle

3. Set the thermostat to "COOL" and the fan switch to "AUTO" and lower the temperature setpoint below the indoor temperature so the system enters the cooling mode.
4. Confirm the outdoor unit compressor is operating.
5. Within 30 seconds of the compressor starting, release a small amount of refrigerant on the refrigerant sensor to activate the leak mitigation mode.
6. Confirm the outdoor unit compressor and fan motor shut down and the indoor blower continues to operate.
7. Confirm the indoor blower is energized and 24V is not present at the air handler pigtail marked "ALARM".
8. Confirm the outdoor unit compressor and fan motor are re-energized approximately 5 minutes after the flow of refrigerant near the sensor has ended and that the indoor blower continues to operate.

Leak Detected During the OFF Cycle

9. Set the thermostat to the "OFF" position and wait until the outdoor unit compressor and fan motor stop and indoor blower stops.
10. Release a small amount of refrigerant on the refrigerant sensor to activate the leak mitigation mode

11. Confirm the indoor blower is energized and 24V is not present at the air handler pigtail marked "ALARM".
12. Confirm the indoor blower shuts down after approximately 5 minutes after the flow of refrigerant on the refrigerant sensor has ended.
13. If the Refrigerant Leak Mitigation System does not operate as stated above, check for loose wiring connections or replace the refrigerant sensor.
14. Reinstall the blower/control box access panel on the air handler.
15. Set the thermostat to the desired operating mode and temperature.

If the leak detection system does not function properly when subjected to the above procedure, check for miswiring of the system. If the wiring connections are found to be correct per the air handler wiring diagram, replace the sensor with an approved replacement from the manufacturer. The replacement sensor part numbers are as follows:

R-32 Refrigerant: R68ALL001

R-454B Refrigerant: R68ALL002

Servicing the Leak Detection System/Sensor Replacement

When the refrigerant leak detection system sensor fails or reaches the end of its life, the leak detection system will enter and remain in the leak mitigation mode even though there is no refrigerant leak present. If the leak detection system continues to operate in the mitigation mode even when a refrigerant leak isn't indicated by a portable refrigerant leak detector, replace the sensor with an approved replacement from the air handler manufacturer using the following procedure.

Refrigerant Sensor Replacement Procedure

The refrigerant sensor is attached to a bracket near the bottom right side of the indoor coil on the blower side of the coil. Disconnect the wiring harness connector from the failed sensor and remove the sensor mounting screws. Discard the failed sensor. Mount the replacement sensor in the same location as the failed sensor that was removed and connect the sensor wiring harness connector to the sensor. Verify the proper function of the refrigerant leak mitigation system using the procedure described earlier.

IMPORTANT: Mortex may source sensors from various manufacturers that have a different wiring harness connection. A wiring may be necessary to allow the replacement sensor to connect the sensor wiring harness. The wiring adapter will be provided with the replacement sensor. Alternate mounting holes are provided in the sensor bracket to accommodate the various approved sensors. Only use a replacement sensor approved by and provided by Mortex to assure proper operating and compatibility.

IMPORTANT: The wiring harness plug must be pointing down or horizontal. If the plug is pointing up, water could collect in the plug and result in operational issues.

SECTION 9: FIELD INSTALLED ACCESSORIES

Part Number	Description
R72DB0101DF	Field Installed TXV (R-32) - 1.5-3.0 Ton
R72DB0103DF	Field Installed TXV (R-454B) - 1.5-3.0 Ton
68AC0002	Field Installed Replacement Pump Timer for Hydronic Coil Purge
R78AA0006	4 GPM Water Pump
RPA-01	Remote Pump Assembly 4 GPM 1/2" Pipe
RPA-02	Remote Pump Assembly 4 GPM 3/4" Pipe
RPA-03	Remote Pump Assembly 7 GPM 3/4" Pipe
WPD02	Wall Panel Door for 02 Models
WPD03	Wall Panel Door for 03 Models
LCD02	Wall Panel Door for 02 Models
LCD02	Louvered Coil Door for 03 Models
WPD02	Louvered Coil Door for 02 Models
BRP02	Bottom Return Air Panel for 02 Models
BRP03	Bottom Return Air Panel for 03 Models
WB	Wall Mounting Brackets

Table 5: Field Installed Accessory List

SECTION 10: REPLACEMENT PARTS

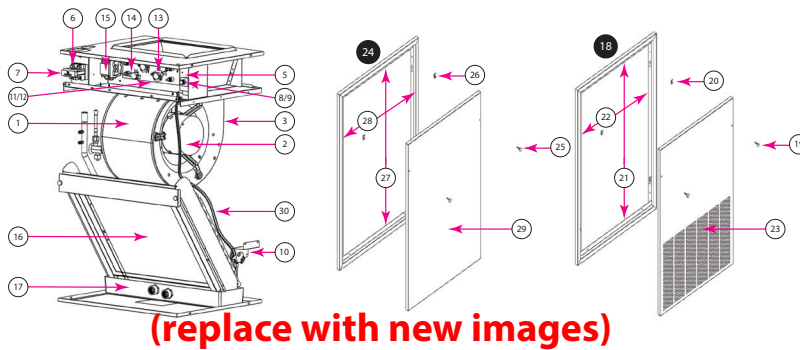
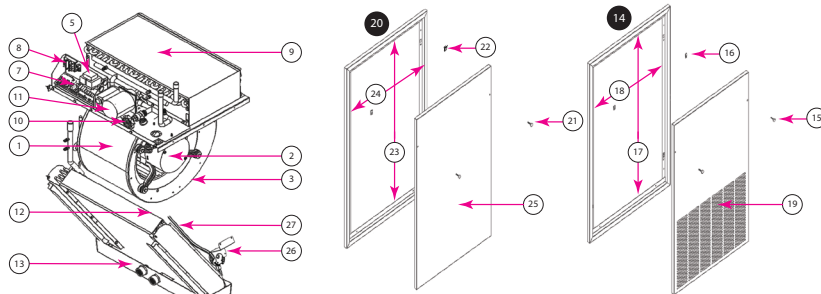

Figure 20: Replacement Parts Schematic – B/S-02 / Electric Heat

B/S-02 ELECTRIC HEAT MODELS - Blower Code XD			
Item #	Qty.	Part #	Description
1	1	86HM00XD-02	1/3 HP – 208/240V - 10 X 6 Blower Assembly (Complete Assembly) - XD
2	1	65BV0025R	1/3 HP - 208/240V - Constant Torque Motor
3	1	69AC0001	10 x 6 Blower Wheel 1/2" Hub - CW Rotation
4	1	R68AA0003	208/240-24V Transformer
5	1	R68DC0001	Ground Lug
6	1	R68DC0018	Power Terminal Block - S-02 Only
7	1	R73MH0001	3 Amp Fuse
8	1	R73MHA001	Fuse Holder
9	1	R68ALL001	Refrigerant Leak Sensor – R-32
10	1	R68ALL002	Refrigerant Leak Sensor – R-454B
11	1	R73BB0053	Refrigerant Leak Sensor Wire Harness
5 kW Electric Heat			
12	1	R67AB0015	5 kW Element
13	1	R68CA0002	Auto-Reset Limit Switch (Opens at 130°F - Closes at 100°F)
14	1	R68CA0011	Non-Resettable Limit Switch - Opens 190°F
15	1	R68AB0019	Double Pole Electric Heat Contactor - 50 Amp Resistive
16	1	R68BAD013	30 Amp 230 SQD Circuit Breaker - B-02 Only
8 kW Electric Heat			
12	1	R67AB0016	8 kW Element
13	1	R68CA0002	Auto-Reset Limit Switch (Opens at 130°F - Closes at 100°F)
14	1	R68CA0011	Non-Resettable Limit Switch - Opens 190°F
15	1	R68AB0019	Double Pole Electric Heat Contactor - 50 Amp Resistive
16	1	R68BAD016	45 Amp 245 SQD Circuit Breaker - B-02 Only
10 kW Electric Heat			
12	1	R67AB0017	10 kW Element
13	1	R68CA0002	Auto-Reset Limit Switch (Opens at 130°F - Closes at 100°F)
14	1	R68CA0011	Non-Resettable Limit Switch - Opens 190°F
15	2	R68AB0019	Double Pole Electric Heat Contactor - 50 Amp Resistive
16	1	R68BAD018	60 Amp 260 SQD Circuit Breaker - B-02 Only
DX Coil			
17	1	DX coil part number depends on specific model. Contact factory sales rep to obtain the correct coil	
DRAIN PANS (PLASTIC)			
18	1	R71AA0042	21.00" W x 5.355" D - Horizontal

Table 6: Replacement Parts List – B/S-02 / Electric Heat Repair Parts List



(replace with new images)

Figure 21: Replacement Parts Schematic – B/S-03 / Electric Heat

B/S-03 ELECTRIC HEAT MODELS - Blower Code XC			
Item #	Qty.	Part #	Description
1	1	86HM00XC-03	1/2 HP- 208/240V - 10 X 7 Blower Assembly (Complete Assembly) - XC
2	1	65BV0026R	1/2 HP - 208/240V - Constant Torque Motor
3	1	69AC0002	10 x 7 Blower Wheel 1/2" Hub - CW Rotation
4	1	R68AA0003	208/240-24V Transformer
5	1	R68DC0001	Ground Lug
6	1	R68DC0018	Power Terminal Block - S-03 Only
7	1	R73MH0001	3 Amp Fuse
8	1	R73MHA001	Fuse Holder
9	1	R68ALL001	Refrigerant Leak Sensor – R-32
10	1	R68ALL002	Refrigerant Leak Sensor – R-454B
11	1	R73BB0053	Refrigerant Leak Sensor Wire Harness
5 kW Electric Heat			
12	1	R67AB0015	5 kW Element
13	1	R68CA0002	Auto-Reset Limit Switch (Opens at 130°F - Closes at 100°F)
14	1	R68CA0011	Non-Resettable Limit Switch - Opens 190°F
15	1	R68AB0019	Double Pole Electric Heat Contactor - 50 Amp Resistive
16	1	R68BAD013	30 Amp 230 SQD Circuit Breaker - B-03 Only
8 kW Electric Heat			
12	1	R67AB0016	8 kW Element
13	1	R68CA0002	Auto-Reset Limit Switch (Opens at 130°F - Closes at 100°F)
14	1	R68CA0011	Non-Resettable Limit Switch - Opens 190°F
15	1	R68AB0019	Double Pole Electric Heat Contactor - 50 Amp Resistive
16	1	R68BAD016	45 Amp 245 SQD Circuit Breaker - B-03 Only
10 kW Electric Heat			
12	1	R67AB0017	10 kW Element
13	1	R68CA0002	Auto-Reset Limit Switch (Opens at 130°F - Closes at 100°F)
14	1	R68CA0011	Non-Resettable Limit Switch - Opens 190°F
15	2	R68AB0019	130°F Limit Switch (Opens at 130°F - Closes at 100°F)
16	1	R68BAD018	60 Amp 260 SQD Circuit Breaker - B-03 Only
DX Coil			
17	1	DX coil part number depends on specific model. Contact factory sales rep to obtain the correct coil	
DRAIN PANS (PLASTIC)			
18	1	R71AA0042	21.00"W x 5.355" D - Horizontal

Table 7: Replacement Parts List – B/S-03 Electric Heat Air Handler

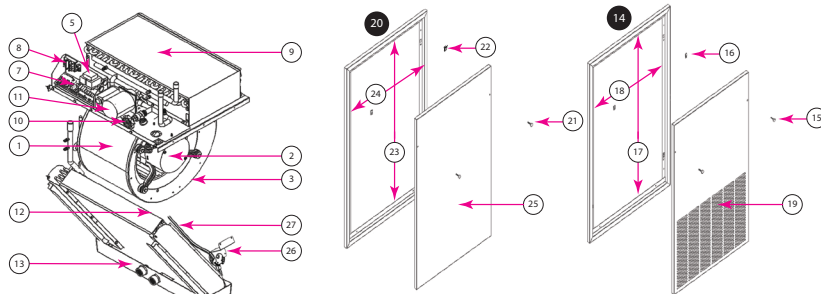

(replace with new images)

Figure 22: Replacement Parts Schematic – H-02 Hydronic Heat

H-02 HYDRONIC HEATING MODELS – BLOWER CODE XE			
Item #	Qty.	Part #	Description
1	1	86HM00XE-02	1/3 HP - 115-10 X 6 Blower Assembly (Complete Assembly) - XE
2	1	65BV0021R	1/3 HP 115 VAC Constant Torque Motor
3	1	69AC0001	10 x 6 Blower Wheel 1/2" Hub - CW Rotation
4	1	R68AA0002	115 - 24V Transformer
5	1	R68DC0001	Ground Lug
6	1	R68DC0018	Power Terminal Block
7	1	R68AE0011	Hydronic Control Board For Constant Torque Motors
8	1	R68DD0005	White Wire Freeze Protector
9	1	R68DD0006	Yellow Wire Compressor Lockout Switch
10	1	R66AB0006	Sensor Clip HW/AH
11	1	R74BA0004	Valve - Air Bleed Body
12	1	R74BA0005	Valve - Air Bleed Core
13	1	R74BB0001	1/2" Boiler Drain
14	1	R86CB0004	3 Row Hot Water Coil 14 x 12.5
15	1	R78AA0007	4 GPM Taco Circulating Pump 115V
16	1	R68ALL001	Refrigerant Leak Sensor – R-32
17	1	R68ALL002	R68ALL002 Refrigerant Leak Sensor – R-454B
18	1	R73BB0053	R73BB0053 Refrigerant Leak Sensor Wire Harness
DX Coils			
19	1		DX coil part number depends on specific model. Contact factory sales rep to obtain the correct coil.
DRAIN PANS (PLASTIC)			
20	1	R71AA0042	21.00" W x 5.355" D - Horizontal

Table 8: Replacement Parts List - H-02 Hydronic Heat Air Handler

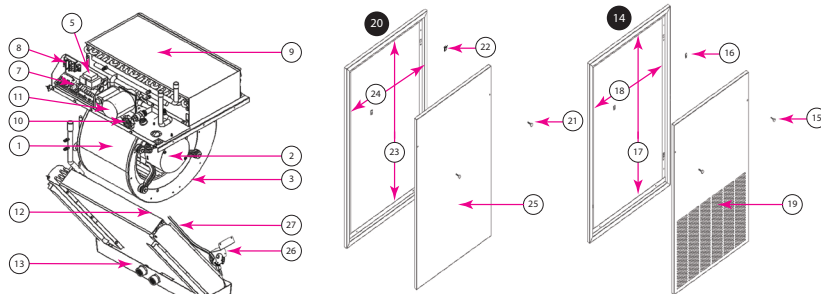

(replace with new images)

Figure 23: Replacement Parts Schematic – H-03 / Hydronic Heat

H-03 HYDRONIC HEAT MODELS – BLOWER CODE XF			
Item #	Qty.	Part #	Description
1	1	86HM00XF-03	1/2 HP -115V - 10 x 8 Blower Assembly (Complete Assembly) - XF
2	1	65BV0022R	1/2 HP - 115V - Constant Torque Motor
3	1	69AB0001	10 x 8 Blower Wheel 1/2" Hub - CW Rotation
4	1	R68AA0002	115 - 24V Transformer
5	1	R68DC0001	Ground Lug
6	1	R68DC0018	Power Terminal Block
7	1	R68AE0011	Hydronic Control Board For Constant Torque Motors
8	1	R68DD0005	White Wire Freeze Protector
9	1	R68DD0006	Yellow Wire Compressor Lockout Switch
10	1	R66AB0006	Sensor Clip HW/AH
11	1	R74BA0004	Valve - Air Bleed Body
12	1	R74BA0005	Valve - Air Bleed Core
13	1	R74BB0001	1/2" Boiler Drain
14	1	R86CKC101	4 Row Hot Water Coil 16 x 12.5
15	1	R78AA0007	4 GPM Pump 115V
16	1	R68ALL001	Refrigerant Leak Sensor – R-32
17	1	R68ALL002	R68ALL002 Refrigerant Leak Sensor – R-454B
18	1	R73BB0053	R73BB0053 Refrigerant Leak Sensor Wire Harness
DX Coils			
19	1		DX coil part number depends on specific model. Contact factory sales rep to obtain the correct coil.
DRAIN PANS (PLASTIC)			
20	1	R71AA0042	21.00" W x 5.355" D - Horizontal

Table 9: Replacement Parts List - H-03 Hydronic Heat Air Handler

When the air handler is at the end of its life and is being removed for replacement, proper procedures must be followed to assure the safety of the technician and building occupants due to the flammable refrigerant contained in the refrigeration system. Before performing this procedure, it is essential that the technician is completely familiar with the equipment and all its detail. It is recommended good practice that all refrigerants are recovered safely. Prior to the task being performed, an oil and refrigerant sample shall be taken in case analysis is required prior to re-use of recovered refrigerant. It is essential that electrical power is available before the task is commenced.

Decommissioning Procedure

- a) Become familiar with the equipment and its operation
- b) Before attempting the procedure, ensure that:
 - mechanical handling equipment is available, if required, for handling refrigerant cylinders;
 - all personal protective equipment is available and being used correctly;
 - the recovery process is supervised at all times by a competent person;
 - recovery equipment and cylinders conform to the appropriate standards.
- c) Pump down the refrigerant into the outdoor unit, if possible, by closing the outdoor unit liquid service valve and energizing the compressor until the suction pressure is near atmospheric pressure. If pumping the system down is not possible due to an inoperable compressor, the refrigerant must be recovered.
- d) If a vacuum is not possible, make a manifold so that refrigerant can be removed from various parts of the system
- e) Make sure that the recovery cylinder is situated on the scales before recovery takes place.
- f) Start the recovery machine and operate in accordance with instructions. (Also, refer to Refrigerant Recovery Requirements in the next column.)
- g) Do not overfill cylinders (no more than 80 % volume liquid charge).
- h) Do not exceed the maximum working pressure of the cylinder, even temporarily.
- i) When the cylinders have been filled correctly and the process completed, make sure that the cylinders and the equipment are removed from site promptly and all isolation valves on the equipment are closed off.
- j) Recovered refrigerant shall not be charged into another refrigerating system unless it has been cleaned and checked.
- k) Once all of the refrigerant has been pumped into the outdoor unit or has been recovered, disconnect the refrigerant lines from the air handler. Continuously flush or purge with inert gas when using a flame to open the circuit at the field refrigerant line connections.
- l) Turn the circuit breaker(s) serving the air handler in the main electrical panel to the OFF position. If a disconnect switch has been installed near the air handler, switch it to the OFF position.

- m) Disconnect all electrical wiring from the air handler.
- n) Once the refrigerant lines and electrical wiring have been disconnected from the air handler, remove the air handler from the property and dispose of it. Taking the air handler to recycling center is encouraged.
- o) Equipment shall be labelled stating that it has been decommissioned and emptied of refrigerant. The label shall be dated and signed. For appliances containing flammable refrigerants, ensure that there are labels on the equipment stating the equipment contains flammable refrigerant.

Refrigerant Recovery Requirements

When removing refrigerant from a system, either for servicing or decommissioning, it is recommended good practice that all refrigerants are removed safely.

When transferring refrigerant into cylinders, ensure that only appropriate refrigerant recovery cylinders are employed. Ensure that the correct number of cylinders for holding the total system charge is available. All cylinders to be used are designated for the recovered refrigerant and labelled for that refrigerant (i.e. special cylinders for the recovery of refrigerant). Cylinders shall be complete with pressure-relief valve and associated shut-off valves in good working order. Empty recovery cylinders are evacuated and, if possible, cooled before recovery occurs

The recovery equipment shall be in good working order with a set of instructions concerning the equipment that is at hand and shall be suitable for the recovery of the flammable refrigerant. If in doubt, the manufacturer should be consulted. In addition, a set of calibrated weighing scales shall be available and in good working order. Hoses shall be complete with leak-free disconnect couplings and in good condition.

The recovered refrigerant shall be processed according to local legislation in the correct recovery cylinder, and the relevant waste transfer note arranged. Do not mix refrigerants in recovery units and especially not in cylinders.

If compressors or compressor oils are to be removed, ensure that they have been evacuated to an acceptable level to make certain that flammable refrigerant does not remain within the lubricant. The compressor body shall not be heated by an open flame or other ignition sources to accelerate this process. When oil is drained from a system, it shall be performed safely.