

**MULTI-POSITION 28" DEEP MODULAR AIR HANDLER
WITH OR WITHOUT ELECTRIC HEAT
MODELS: MSVT Series**

**For Installation In
1. Modular Homes & Buildings
2. Residential Homes**

LIST OF SECTIONS - USERS INFORMATION MANUAL

1 – General.....1	4 – Startup and Shutdown Instructions..... 5
2 – Safety.....2	5 – Owner Maintenance..... 5
3 – Owner’s Information and Seasonal Information.....3	

LIST OF SECTIONS -SERVICE AND MAINTENANCE MANUAL

1 – Safety.....7	5 – Troubleshooting 10
2 – Air Handler Maintenance.....8	6 – Blower Performance..... 13
3 – Air Handler Controls.....9	7 – Accessories and Replacement Parts..... 14
4 – Sequence of Operation 10	

LIST OF FIGURES

1 – Air Handler and Cooling Coil Examination Check Points.....3	9 – Control Box With Electric Heat Installed9
2 – Front Access Panel Circuit Breaker Location.....4	10 – Constant Torque Motor Terminals..... 11
3 – Homeowner / User Cleaning Points5	11 – Electric Heater Contactor Terminals..... 12
4 – Accessory Air Filter Base6	12 – Blower Assembly and Mounting Screw Locations12
5 – Accessory Filter Base – Adjustment for 1" and 2" Filters6	13 – MMVT 24A Replacement Parts Schematic15
6 – Return Air Filter Grille.....6	14 – MMVT 36B, 48B Replacement Parts Schematic.....16
7 – Blower Assembly and Mounting Screw Locations8	15 – MMVT 48C, 60C, 60D Replacement Parts Schematic16
8 – Component Locations – Shown Without Electric Heat9	

LIST OF TABLES

1 – Constant Torque Motor Terminal Descriptions..... 11	5 – MMVT 24A, 36A Replacement Parts List 15
2 – 120 VAC Blower Motor Full Load Amperage (FLA) Chart 11	6 – MMVT 36B, 48B Replacement Parts List..... 16
3 – Blower Performance..... 13	7 – MMVT 48C, 60C, 60D Replacement Parts List 17
4 – Accessory List..... 14	

CONTACT INFORMATION

Manufactured and Distributed by:	Mortex Products, Inc. 501 Terminal Rd Fort Worth, TX 76106	www.mortx.com
----------------------------------	--	---------------

SECTION 1: GENERAL

The following list includes important facts and information regarding the air handler models covered in this manual.

1. Electric heat air handlers are rated for 120V at 60 Hz (blower motor circuit only) and 208/240 VAC (electric heat circuit only) at 60 Hz.
2. Air handler models are available in a medium or large cabinet.
3. All air handlers are designed for A/C or heat pump operation.
4. All air handlers are designed for upflow, downflow and horizontal applications.
5. The air handler must not be operated without the access panels installed.
6. This air handler and its components are listed by ETL in the United States and Canada.
7. This air handler is for use at elevations of 10,000 ft (3,048m) or less.
8. This appliance is not to be used by persons (including children) with reduced physical, sensory or mental capabilities, or lack of experience and knowledge, unless they have been given supervision or instruction concerning use of this appliance by a person responsible for their safety. Children must not be allowed to play with this appliance.

**USERS MUST READ ALL INSTRUCTIONS IN THIS MANUAL.
THIS MANUAL MUST BE SAVED FOR FUTURE REFERENCE.**



This is a safety alert symbol. When this symbol is seen on labels or in manuals, be alert to the potential for personal injury. Understand and pay particular attention to the signal words **DANGER**, **WARNING**, or **CAUTION**.

DANGER: Indicates an imminently hazardous situation, which if not avoided, **will result in death or serious injury**.

WARNING: Indicates a potentially hazardous situation, which if not avoided, **could result in death or serious injury**.

CAUTION: Indicates a potentially hazardous situation, which if not avoided, **may result in minor or moderate injury**. It is also used to alert against unsafe practices and hazards involving property damage.

WARNING

FIRE OR ELECTRICAL HAZARD

Failure to follow the safety warnings exactly could result in serious injury, death, or property damage.

A fire or electrical hazard may result causing property damage, personal injury or loss of life.

Do not store or use gasoline or other flammable vapors and liquids in the vicinity of this air handler or any other appliance.

WARNING

Any adjustment, service or maintenance by the homeowner and/or user may create a condition where the operation of the product could cause personal injury or property damage.

Only qualified service personnel, a contractor, or an installer may refer to the service and maintenance section of this manual for assistance or for additional service or repair information on this air handler.

CAUTION

This product requires periodic routine maintenance and cleaning of the exterior surfaces by the homeowner or user to remove dust and debris. Any additional service must be performed by qualified personnel. This air handler must be serviced and maintained as specified in these instructions and/or to any applicable local, state, and national codes including, but not limited to building, electrical, and mechanical codes.

DANGER

Do not use this air handler if any part has been under water. A flood damaged air handler is extremely dangerous. Attempts to use the air handler can result in a fire. A qualified contractor, installer, or service agency must be contacted to inspect the air handler for any water damage and replace all components, control system parts, or electrical parts that have been damaged. If enough damage is present, the air handler may need to be replaced.

Safety Requirements

1. This air handler must be kept clear and free of combustible materials, gasoline and other flammable vapors and liquids.
2. Never store flammable materials of any kind near this air handler. Gasoline, solvents and other volatile liquids should be stored only in approved containers outside the home. These materials vaporize easily and are extremely dangerous.
3. Insulating materials may be combustible. The air handler must be kept free and clear of insulating materials. The air handler area must be examined when installed in an insulated space or when insulation is added to be sure that the insulation material has been kept away from the air handler.
4. Follow the instructions exactly as shown in **Section 4: Startup and Shutdown Instructions** in this manual to properly start up or shut down this air handler.
5. If overheating occurs, turn the power off to the air handler and contact a qualified contractor, installer, or service agency.
6. Never store cleaning materials such as bleaches, detergents, powder cleaners, etc. near the air handler. These chemicals can cause corrosion of the air handler sheet metal and the electric heaters, the blower and the electrical controls.
7. Never use the area around the air handler as a storage area for items which could block or obstruct air-flow the space around the air handler. This flow of air is required for safe and proper operation. Never block or obstruct air openings used for ventilation and cooling of the air handler electrical components.
8. Refer to the air handler rating plate for requirements for safe operation.
9. Provide clearance for service access to the control box, electric heat elements or hydronic coil, and blower.
10. Failure to carefully read and follow all instructions in this manual can result in malfunction of the air handler, death, personal injury, and/or property damage.
11. If the air handler is installed in a residential garage, it must be installed so that the electric heaters are located no less than 18 inches above the floor and the air handler must be located or protected to avoid physical damage by vehicles.
12. These instructions cover minimum requirements and conform to existing national standards and safety codes.
13. In some cases, these instructions exceed certain local codes and ordinances, especially those who have not kept up with changing modular home and residential home construction practices. These instructions are to be followed and are the minimum requirement to perform service or repairs on this air handler.

WARNING

FIRE OR ELECTRICAL HAZARD

Servicing heating/cooling equipment can be hazardous due to electrical components.

Only trained and qualified personnel can service or repair heating/cooling equipment. The homeowner must never try to perform service, repair or maintenance on this air handler.

Untrained service personnel can perform only basic maintenance functions such as cleaning of exterior surfaces and replacing the air filters.

Observe all precautions in the manuals and on the attached labels when working on this air handler.

SECTION 3: OWNERS INFORMATION AND SEASONAL INFORMATION

How The Air Handler Works – Continuous Fan:

When the thermostat fan switch is set to the “ON” position, the air handler blower motor will operate continuously to help circulate air through the home and air handler air filter.

How The Air Handler Works – Electric Heat:

When the thermostat calls for heat on non-heat pump systems, the heater contactor is energized, sending 208/240 VAC through to the electric heaters causing them to heat up. The indoor fan motor is then energized which causes the circulating blower to draw air from the living space, passes it across the heater coils, and circulates the warmed air through the duct system to the living space. When the thermostat is satisfied, the electric heaters are de-energized and the blower is de-energized after an “OFF” time delay. The heating cycle has ended and the air handler is now in the stand-by mode awaiting the next call for heat.

How The Air Handler Works – Cooling Cycle

When the thermostat calls for cooling operation, the compressor in the outdoor unit is energized in the cooling mode. The indoor fan motor is also energized which causes the circulating blower to draw air from the living space, passes it across the cooling coil in the air handler, and circulates the cooled air through the duct system to the living space. When the thermostat is satisfied, the outdoor unit is de-energized which turns off the compressor and outdoor fan motor. The blower is de-energized after an “OFF” time delay. The cooling cycle has ended and the air handler is now in the stand-by mode awaiting the next call for cooling.

How The Air Handler Works – Heat Pump Heating Cycle

When the thermostat calls for heat pump heating operation on heat pump systems, the compressor and fan motor in the outdoor unit are energized. If not already in the heating position from a previous heating cycle, the reversing valve in the outdoor unit switches position causing the flow of the refrigerant to reverse and heat the coil inside the air handler. The indoor fan motor is energized which causes the circulating blower to draw air from the living space, passes it across the coil in the air handler, and circulates the warmed air through the duct system to the living space. If the heat pump heating mode is insufficient to satisfy the thermostat set point, supplemental electric heat is energized as needed to supply the additional necessary heat to heat the home.

When the thermostat is satisfied, the compressor contactor is de-energized which turns off the compressor and outdoor fan motor. The blower is also de-energized after an “OFF” time delay. The heat pump heating cycle has ended and the air handler is now in the stand-by mode awaiting the next call for heat pump heating.

Examination of the Air Handler

The homeowner should perform a visual examine the air handler every month for any defects or problems. The items to be inspected are:

1. The physical support of the air handler is sound without sagging cracks, gaps, etc. around the base to provide a seal between the support and the base.
2. The air handler casing for any signs of deterioration from rust or corrosion.
3. The return and supply duct connections are physically sound and are sealed to the air handler casing.
4. The air handler must be serviced by qualified personnel annually, preferably at the start of each heating season.

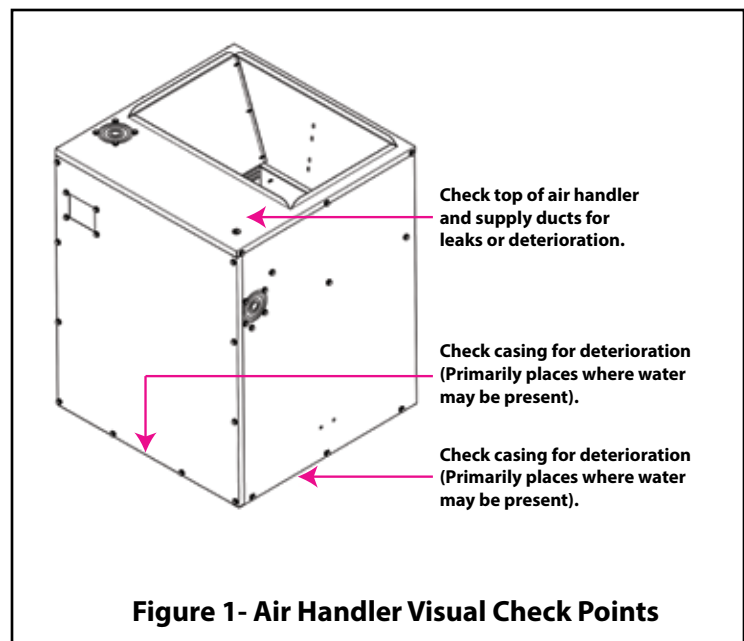

Figure 1- Air Handler Visual Check Points

The Service Technician

If the air handler gives any indication of improper operation, the homeowner or user should call a qualified service technician. The service technician is qualified to perform the normal routine care of the air handler and can detect potential problems and make corrections before trouble develops. Preventative maintenance of this type will allow the air handler to operate with minimal concerns to the homeowner and will add years of comfort. The homeowner or user must not attempt to service or repair this air handler except for tasks presented in **"Section 5: Owner Maintenance" of this User Information Manual.**

Warranty and Responsibilities

It is the sole responsibility of the homeowner to make certain the air handler has been properly installed and adjusted to operate properly.

The manufacturer warrants the air handler to be free from defects in material or workmanship for a stated time in the warranty agreement. The manufacturer will not be responsible for any repair costs to correct problems due to improper setup, improper installation, improper adjustments, installing parts or components on the air handler that are not listed for use with this air handler, improper operating conditions, or repairs performed by the air handler user or homeowner.

Specific examples of service calls which will be excluded from warranty reimbursement are:

1. Correcting faulty duct system in the home. This can be due to not enough ducts or ducts that are too small to provide proper air-flow through the air handler.
2. Correcting electrical wiring problems in the supply wiring to the air handler.
3. Resetting circuit breakers or on/off switches used for servicing.
4. Problems caused by installation and operation of any outdoor unit or air quality devices which are not approved for use with this air handler.
5. Improper thermostat settings or calibrating the thermostat.
6. Problems caused by construction debris which has fallen into the air handler.
7. Replacement of fuses.
8. Insufficient air-flow problems caused by dirty air filters.
9. Air handler malfunction or component premature failure caused by restrictions in the return or supply ducts causing low air-flow.

The homeowner should establish a clear understanding of these responsibilities with the installer and /or service company so there will be no misunderstanding of what will be covered under warranty later.

While Homeowner or User is Away

The air handler is equipped with safety shutoff devices which are designed to prevent it from overheating in case of a malfunction. For this reason, it is never practical to assume the air handler will operate unattended for a long period of time. Examples of a malfunction that can cause significant damage to the home would be:

1. The air handler blower motor fails and the heater elements cycle on the safety shutoff devices while the temperature inside the home continues to drop. Water pipes will freeze and could burst once their temperature falls below 32°F resulting in significant damage to the structure.
2. The air handler blower motor or outdoor unit fails in the summer

resulting in the temperature inside the home to rise above the setpoint. If the temperature of the home rises above the rated temperature of appliances, appliance failure can occur.

3. If the homeowner to be away from home for a long period of time, they should have someone check on the home every day, especially when the outside temperatures will be below 35°F or above 75°F to ensure the air handler is operating properly. This will help prevent water pipes from freezing or appliances from failing.

The Air Handler Fails to Operate Properly

If any abnormalities are observed while the air handler is operating normally, perform the following checks:

1. Check the setting on the thermostat to make sure the thermostat is set above the room temperature.
2. Check to see if the electrical power is turned on at the circuit breakers at the main service circuit breaker box or check any on/off switches that may be used for service disconnect switches, especially ON/OFF switches used for servicing the air handler. These are often mistaken for light switches and are turned off.
3. Check any inline fuses that may have been installed on the air handler to determine if one has blown.
4. Make sure the air filters are clean, return grilles clean, are not obstructed, and supply air registers are open.

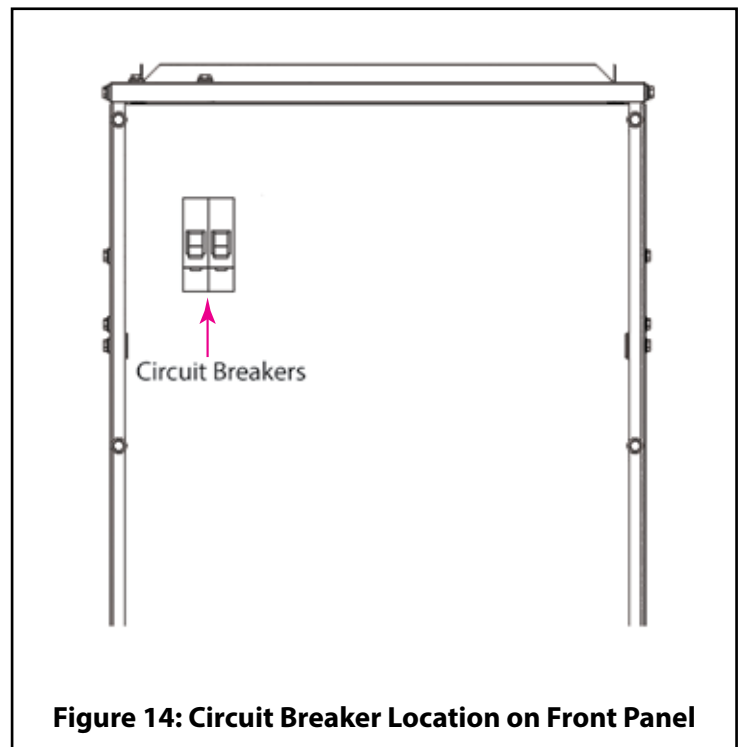

Figure 14: Circuit Breaker Location on Front Panel

WARNING

AIR HANDLERS WITH ELECTRIC HEATERS

Should overheating occur, turn the circuit breakers on the control box and the main electrical service entrance (Home Circuit Breaker Box) to the OFF position. Call qualified service personnel to troubleshoot and repair the air handler. Do not allow the air handler to continue to cycle on the over temperature limit controls.

When to call for service assistance

Very often time can be saved if the homeowner provides the service agency the information about the air handler ahead of time. This will enable the service agency to determine the specific components used and possibly identify the problem, allowing them to arrive with the correct parts to fix the problem. Write down the model number, serial number and be prepared to describe what the air handler is or is not doing and what has already been checked prior to calling the service agency. Read the instructions below before trying to start the air handler.

- 1. BEFORE OPERATING:** Check around perimeter of the air handler to make sure there are no flammable materials in the area. If vapors of any kind are smelled, DO NOT turn on the power to the air handler until vapors have been ventilated and removed from the area of the air handler.
- 2. CHECK THE AIR HANDLER:** Visually check the air handler for loose screws and/or panels that may be missing or have fallen off.
- 3. CHECK DUCT CONNECTIONS:** Visually check the connections of the ducts to the air handler to make sure there are no gaps or holes and ducts are securely fastened to the air handler.

SERVICE AGENCY INFORMATION

Fill in Below

MODEL NUMBER: _____

SERIAL NUMBER: _____

SERVICE COMPANY: _____

ADDRESS: _____

TELEPHONE (DAYTIME): _____

TELEPHONE (EMERGENCY) _____

NOTES: _____

SECTION 4: STARTUP AND SHUTDOWN INSTRUCTIONS

WARNING

Failure to follow the following instructions exactly may result in a fire causing property damage, personal injury, and/or loss of life.

Read the instructions below before trying to start the air handler.

- 1. BEFORE OPERATING:** Check around perimeter of the air handler to make sure there are no flammable materials in the area. If vapors of any kind are smelled, DO NOT turn on the power to the air handler until vapors have been ventilated and removed from the area of the air handler.
- 2. VISUALLY CHECK THE AIR HANDLER:** Visually check the air handler for loose screws and/or panels that may be missing or have fallen off.

- 3. CHECK DUCT CONNECTIONS:** Visually check the connections of the ducts to the air handler to make sure there are no gaps or holes and ducts are securely fastened to the air handler

Turning On / Starting the Air Handler

1. STOP! Read the safety information above before proceeding.
2. Set the thermostat mode to the "OFF" setting.
3. Turn the circuit breakers for the air handler in the main electrical panel to the "ON" position.
4. Turn the circuit breaker(s) located on the front panel of an electric heat air handler to "ON" position (See Figure 2).
5. Turn the service disconnect switch near the air handler (if one is present) to the "ON" position.
6. Set the thermostat to the desired mode and temperature.

Shutting Down / Turning Off the Air Handler

1. Set the thermostat mode to the "OFF" mode.
2. Turn the circuit breaker(s) for the air handler in the main electrical panel to the "OFF" position.
3. Turn the circuit breakers on the front of an electric heat air handler to the "OFF" position (See Figure 2).
4. Turn the service disconnect switch near the air handler (if one is present) to the "OFF" position.

SECTION 5: OWNER MAINTENANCE

All appliances need annual maintenance in order to operate properly. The annual service must be performed by qualified service personnel. The homeowner is expected to perform general cleaning of the exterior surfaces and replacement of the air filters. Air filters must be checked every month and replaced as needed. Figures 4 and 6 indicate the location of the air filters in either an accessory air filter base or return air filter grille.

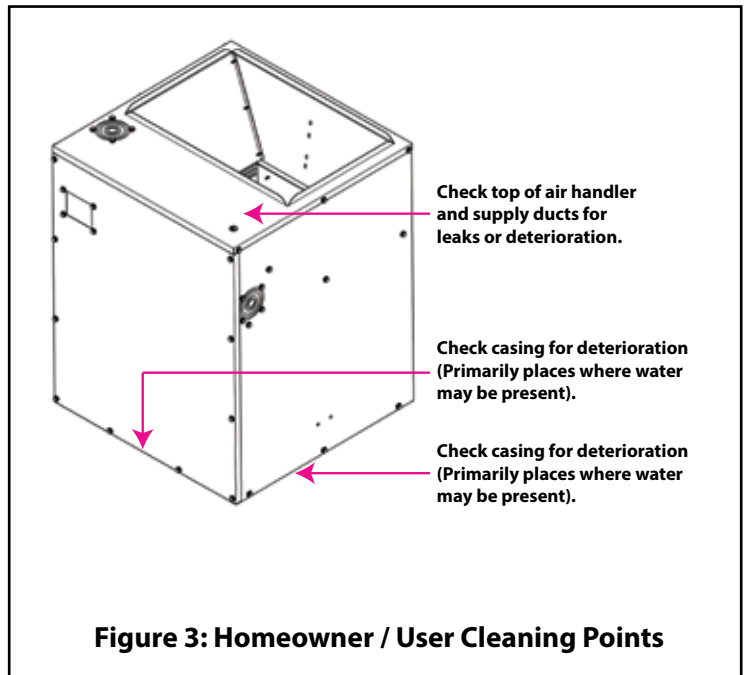

Figure 3: Homeowner / User Cleaning Points

Air Filter Replacement – Accessory Filter Base Kit

Follow these easy steps to replace the air filters.

1. Remove the white handled thumb screws on the front of the accessory filter box kit located just below the air handler.
2. Let the top of the hinged access panel rotate outward.
3. Remove the air filter. The air filter is a disposable filter. Do not attempt to clean the filter and reuse it.
4. Check the size of the air filter that was removed to make sure it is replaced with a filter that is the same size.
5. Clean any excess dirt or debris around the front area where the air filter is located. Be careful not to use any small vacuum cleaner parts or any small brushes to clean inside the filter box, around the filter track. These parts or brushes can fall off or drop into the return duct causing a restriction of the return air-flow.
6. Slide the air filter into the filter rack, push the hinged access panel closed and tighten the thumb screw.

NOTE: Make sure the flow arrows on the air filter are pointing towards the coil.

Downflow / Horizontal Air Filter Replacement

Air handlers that are installed in a downflow or horizontal position generally have filters in one or more filter grilles located in the ceiling and/or wall. Use the following procedure to replace the air filter in a filter grille.

1. Remove the thumb screw(s) on the filter grille or pull down on the latches on each side of the grille to release the hinged grille from the frame (See Figure 6).

Caution: If the grille is mounted in the ceiling, do not stand under the hinged grille when releasing the thumb screws(s) or latches and support the grille until it has been lowered.

2. Carefully allow the hinged grille to rotate downward (ceiling mount) or outward (wall mount) and let it hang open.
3. Remove the air filter. If the air filter is a disposable filter. **Do not attempt to clean the filter and reuse it.**
4. Check the size of the air filter that was removed to make sure it is replaced with the same size filter.
5. Clean any dust or debris from both sides for the louvers and around the area where the filter is placed before the new air filter is installed.
6. Place the new air filter into the grille assembly and push the hinged grille closed. Tighten the thumb screw(s) or push the latches in on each side of the hinged grille until the grille is securely fastened to the frame.

NOTE: Make sure the flow arrows on the air filter are pointing towards the air handler.

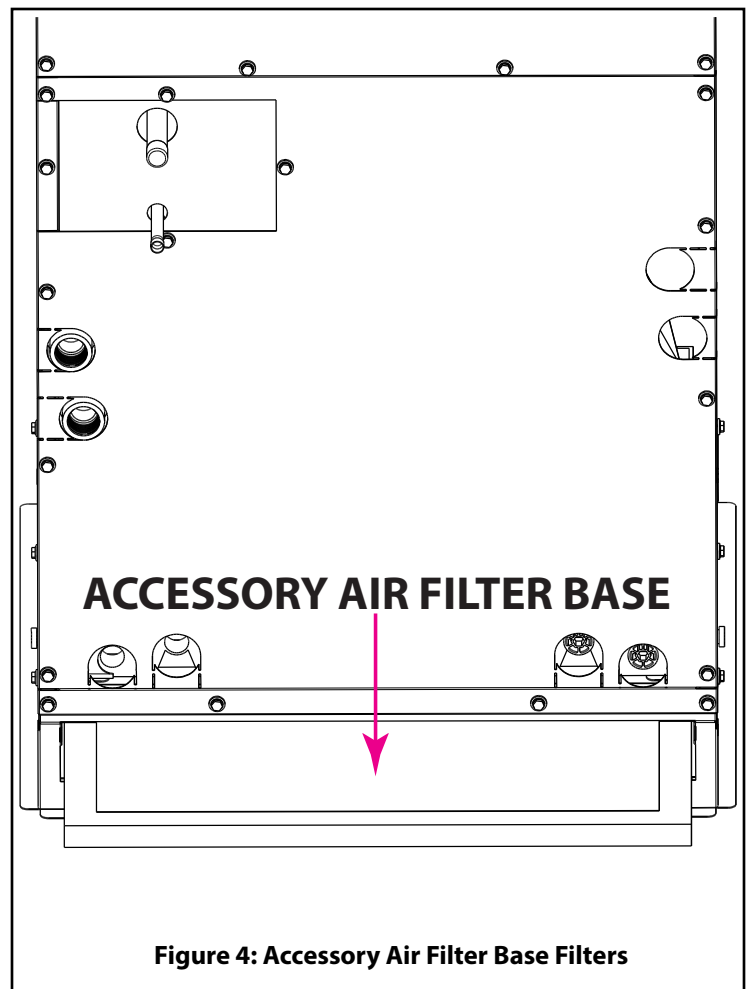

Figure 4: Accessory Air Filter Base Filters

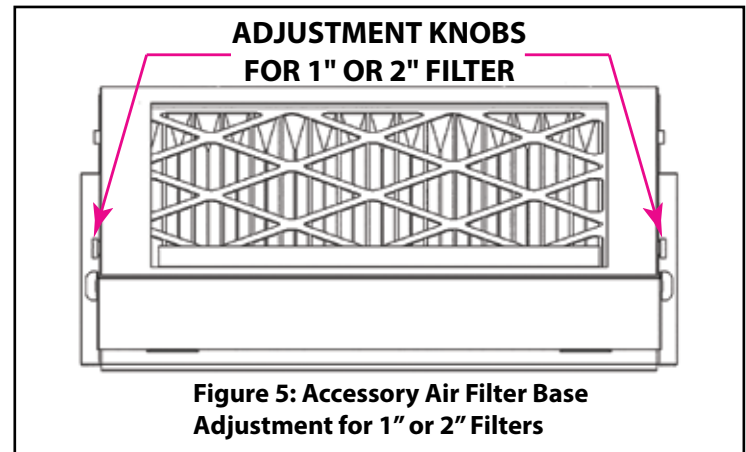

Figure 5: Accessory Air Filter Base Adjustment for 1" or 2" Filters

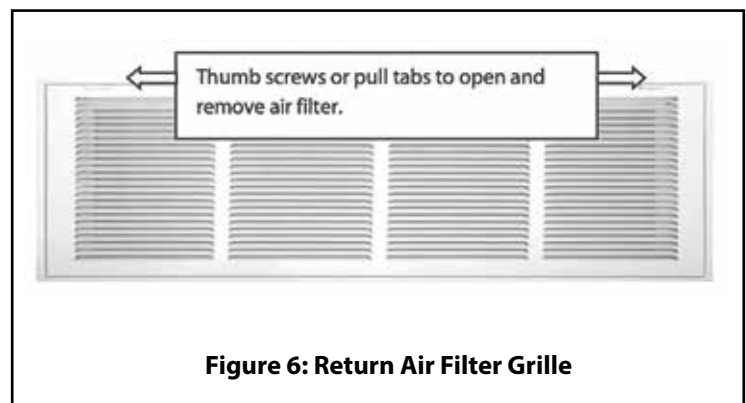

Figure 6: Return Air Filter Grille

SERVICE AND MAINTENANCE MANUAL

SECTION 1: SAFETY

THE HOMEOWNERS AND / OR AIR HANDLER USERS MUST STOP HERE!

This section has been designed to assist a **qualified service technician** in performing service and maintenance on this air handler.

The homeowners and/or the air handler user must never attempt to perform any service or maintenance on the air handler, especially when it involves the removal or adjustment of any parts and/or components.

DANGER

Do not use this air handler if any part has been under water. A flood damaged air handler is extremely dangerous. Attempts to use the air handler can result in a fire. A qualified contractor, installer, or service agency must be contacted to inspect the air handler for any water damage and replace all components, control system parts, or electrical parts that have been damaged. If enough damage is present, the air handler may need to be replaced.



This is a safety alert symbol. When this symbol is seen on labels or in manuals, be alert to the potential for personal injury. Understand and pay particular attention to the signal words **DANGER**, **WARNING**, or **CAUTION**.

DANGER: Indicates an imminently hazardous situation, which if not avoided, **will result in death or serious injury**.

WARNING: Indicates a potentially hazardous situation, which if not avoided, **could result in death or serious injury**.

CAUTION: Indicates a potentially hazardous situation, which if not avoided, **may result in minor or moderate injury**. It is also used to alert against unsafe practices and hazards involving property damage.

SAFETY REQUIREMENTS

1. Air-handlers with electric heaters may have a dual electrical supply circuit. Check each electrical circuit with a meter to be sure the power has been disconnected before servicing.
2. Insulating materials may be combustible. The air handler must be kept free and clear of insulating materials.
3. Follow the instructions exactly as shown in Startup and Shutdown Section in this manual to properly start up or shut down this air handler.
4. Make sure all moving parts have come to a complete stop before attempting to perform any work once the air handler access panels have been removed. Moving parts can cause serious injury if clothing or body parts get caught in the moving part.

WARNING

Improper adjustment, service or maintenance may create a condition where the operation of the product could cause personal injury or property damage. Refer to this manual for assistance or for additional information consult the Technical Support Group.

CAUTION

This product must be serviced and maintained as specified in these instructions and/or to any applicable local, state, and national codes including, but not limited to building, electrical, and mechanical codes.

WARNING

FIRE OR ELECTRICAL HAZARD

Failure to follow the safety warnings exactly could result in serious injury, death, or property damage.

A fire or electrical hazard may result causing property damage, personal injury or loss of life.

WARNING

ELECTRICAL SHOCK, FIRE HAZARD

Failure to follow the safety warnings exactly or improper servicing could result in dangerous operation, serious injury, property damage, and/or death.

- Before servicing, disconnect all electrical power to the air handler. Make sure to disconnect both power supplies if the air handler has a dual power supply circuit. Dual circuits may be used on the 15kW and 20kW models.
- When servicing controls, label all wires prior to disconnecting to aid in proper reconnection of wires.
- Verify proper operation after servicing by turning the thermostat above the room temperature for a brief period of time to ensure proper air handler operation

WARNING

FIRE HAZARD

NEVER PLACE A JUMPER BETWEEN "R" & "W"

Placing jumper wire between the RED and WHITE thermostat wires at the air handler to override the thermostat and energize the heater elements is an extremely dangerous practice that can result in damage to the thermostat, dangerous operation, serious injury, property damage and/or death.

SECTION 2: AIR HANDLER MAINTENANCE

The interior sections of the air handler must be cleaned and adjusted by a qualified service contractor once a year or before the start of each heating or cooling season. The following items must be checked:

1. The blower wheel and motor for excessive dirt.
2. The electric heaters for wear, damage or corrosion.
3. The electrical components for excessive dust, dirt, wear, or deterioration.
4. The supply air duct system for excessive dust, dirt or debris.
5. The return air duct system for excessive dust, dirt or debris.
6. All electrical wiring for wear, insulation cracks and/or damage.
7. Check the indoor coil for dust, debris or damage.
8. Check the indoor coil drain pan for proper drainage to prevent water backup into the air handler.
9. The air handler casing and all interior sheet metal panels or dividers.

Air Handler Cleaning Procedure

1. Follow the instructions exactly as shown in the **Section 4: Startup and Shutdown Section** in the Users Information Manual section of this manual to properly shut down the air handler.
2. Remove the upper access panel on the front of the air handler.
3. Remove the lower access panel on the front of the indoor coil compartment.
4. Unplug the wire harnesses from the blower motor.
5. Remove the two screws on the left and right side and the center screw on the bracket in front of the blower mounting plate and slide the blower out . (See Figure 7)
6. Place a piece of cardboard on top of the indoor coil to prevent dirt or debris from falling onto the coil. Use a vacuum cleaner and a small brush to remove any dirt and debris from the blower and indoor coil compartments.
7. Check the indoor coil condensate drain pan for any debris and into the drain pan.
8. Remove any excess water that may have spilled from checking the indoor coil condensate drain.
9. Check in the area above the blower compartment where the heater elements are located and remove any dust, dirt or debris from around the heater elements. Be careful not to damage the heater elements with the vacuum hose or the brush.
10. Check the blower wheel for dust and debris. Use the brush and the vacuum cleaner to remove any dust or debris from the wheel. Be careful not to move or accidentally remove the blower wheel balance weight(s) located on the wheel blade. Moving or removing a balance weight will cause the blower wheel to vibrate. If the blower wheel is vibrating, it must be replaced.
11. Check the blower motor for dust and debris. Be sure to clean the openings on the motor housing as these openings are used to cool the motor. If the dust, dirt or debris has not been removed from these openings, the motor could run hotter than normal which could shorten the life of the motor.
12. Check and clean any dust in the supply and return ducts with the brush and vacuum cleaner as far as can be reached. If the ducts look like they have an excessive amount of dust, dirt or debris, recommend to the homeowner or user to call a professional to properly clean the duct system.
13. Check and clean any dust, dirt, or debris from all controls and all surfaces in the control box. If dust or dirt is left on the components, they could operate at a much hotter temperature

than normal causing premature component failure.

14. Reinstall the blower assembly and secure the assembly to the blower mounting plate by using the screws that were removed in step 5.
15. Reinstall the lower access panel on the front of the indoor coil compartment.
16. Reinstall the upper access panel on the air handler.
17. Follow the instructions as shown in **Section 4: Startup and Shutdown Section** in the Users Information Manual section of this manual to properly start up the air handler.

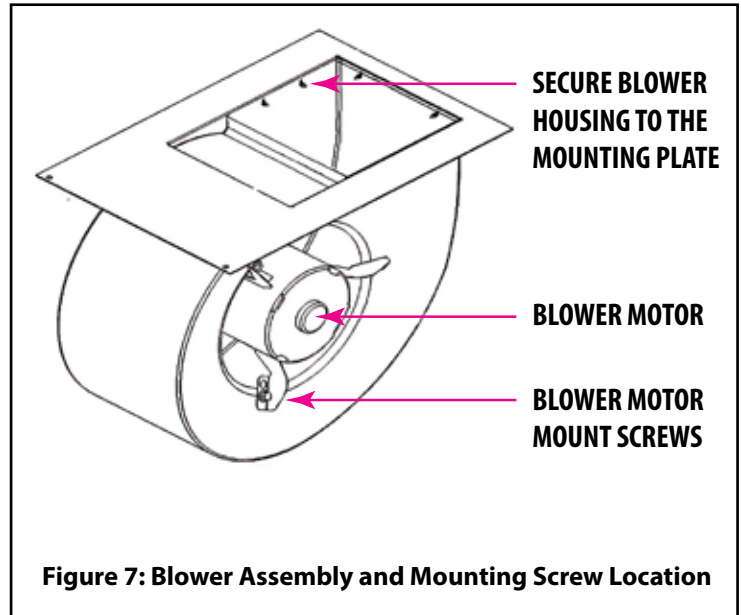

Figure 7: Blower Assembly and Mounting Screw Location

Electric Heat Models

This section discusses the air handler controls and how they operate. Refer to Figures 8 and 9 for component locations.

Limit Control(s) – Each electric heater element has an over temperature limit control directly in front of it to sense overheating of the element. The limit electrical contacts open if the temperature rises above the set point of the limit control and interrupts the 24 VAC signal to the heater contactor coil which de-energizes the heater element. When the temperature of the element cools sufficiently for the limit control to reset, the heater elements are re-energized and the heater cycles until the cause for the overheating is corrected.

In addition to the automatic reset limit switch, each heating element has a non-resettable (one-shot) limit switch that will interrupt 208/240 VAC to the heating element should the automatic reset limit switch fail to function properly in an over-temperature situation.

Heater Contactor(s) – The electric heater contactor turns the heater elements on and off. The contactor is controlled by the

thermostat. On a call for heat by the thermostat, 24 VAC is applied to the 24 VAC coil of the contactor causing the electrical contacts of the contactor to close which energizes the heater elements. When the call for heat has been satisfied, the 24 VAC signal is removed from the 24 VAC coil on the contactor causing the electrical contacts of the contactor to open which de-energizes the heater elements. Models with 5kw and 10kw heaters have a single contactor and 15kw and 20kw heaters have two contactors.

Circuit Breaker(s) – The circuit breakers provide over-current protection for the air handler internal electrical components. Circuit breakers or fuses in the home's breaker box and must be sized to protect the line voltage wires connected to the air handler circuit breakers. Models with 5kw and 10kw heaters have a single circuit breaker and 15kw and 20kw heaters have two circuit breakers.

Transformer – The transformer is used to reduce line voltage from 120VAC to 24 VAC. The transformer provides the required 24 VAC for the system control circuit.

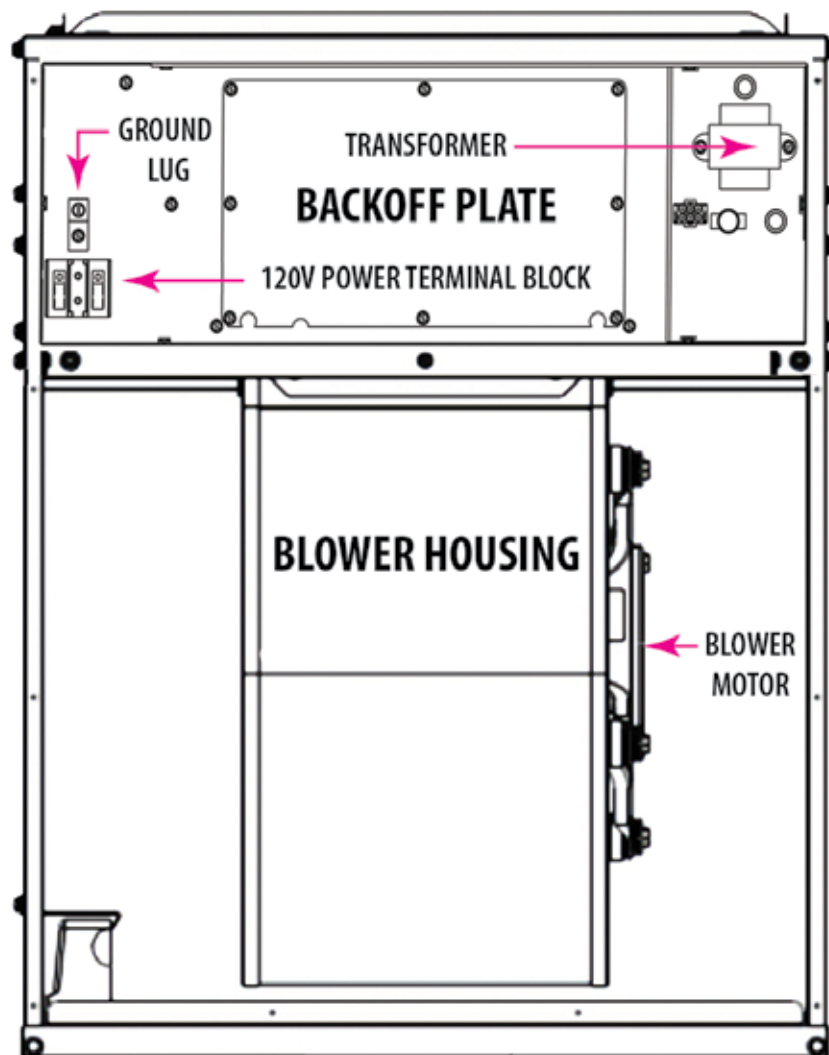

Figure 8: Component Locations

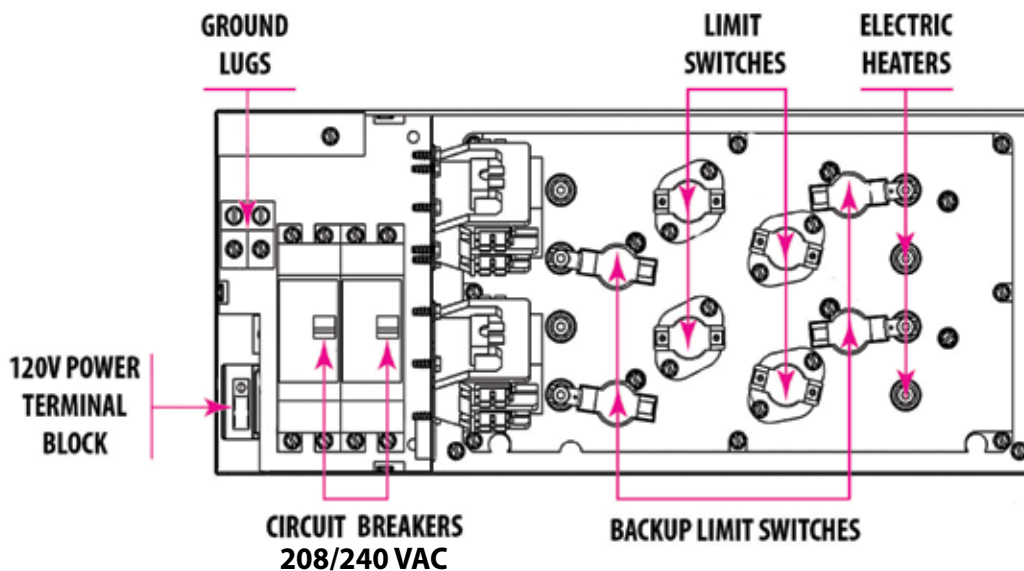

Figure 9: Component Locations – Electric Heat Control Box

SECTION 4: SEQUENCE OF OPERATION

Continuous Blower

The thermostat has a manual fan switch that can be moved to the "ON" position for continuous fan position. This setting causes the thermostat to complete the circuit between "R" and "G" thermostat terminals. For models with constant torque motors, this sends 24 VAC to the selected indoor blower motor speed tap for the cooling mode (BLACK motor speed tap wire). The indoor blower will operate continuously until the fan switch on the thermostat is switched from "ON" to the "AUTO" setting which will cause the constant torque blower motor to be de-energized after a 30 second OFF time delay that is programmed into the motor's control module.

Intermittent Blower – Cooling

The thermostat has a manual fan switch that can be moved to the "AUTO" position for intermittent fan operation. When the thermostat calls for cooling on models with constant torque motors, the circuit is completed between the "R", "Y" and "G" terminals causing the motor to operate on the selected speed tap for the cooling mode (BLACK motor speed tap wire).

When the thermostat is satisfied, the circuit between "R", "Y" and "G" will open, the blower motor will shut down after a 30 second OFF delay which is programmed into the motor control module.

Intermittent Blower - Heating - Electric Heat

When the thermostat is set to the HEAT mode and the fan switch on the thermostat is set to AUTO, the call for heat closes the thermostat circuit between the "R" and "W" terminals. 24 VAC is sent from the "W" terminal on the thermostat, through the white thermostat wire, the white pigtail wire on the air handler to the 24 VAC coil on the first heater contactor. This signal energizes the heater contactor, closing the contacts and sending 208 - 240 VAC to the heaters. The 24 VAC signal from the "W" thermostat terminal will also energize the motor's selected heating speed tap (RED motor speed tap wire). When the call for heat has ended, the "W" thermostat terminal is de-energized which will de-energize the motor and open the heater contactor contacts. The air handler is now in the stand-by mode awaiting the next heating cycle.

Some models have a "W2" terminal that is connected to the 24 VAC coil on the second heater contactor. This terminal is to be used for

second stage heat and is connected to the wire from the thermostat "W2" terminal. A thermostat that has a second stage heating feature (W2 terminal) is required to use this feature. The second stage heat cycle is typically enabled when the room temperature typically falls more than 3 degrees below the thermostat heating set point. The thermostat energizes the second stage heater to aid in heating the room back to the thermostat set point. Once the room temperature is within one degree of the thermostat heating set point, the second stage heater is de-energized until the thermostat calls for second stage heat again.

SECTION 5: TROUBLESHOOTING

If 120 VAC is present at the 120 VAC terminal block, check to make sure there is 24 VAC between to the RED thermostat pigtail or "R" low voltage terminal block terminal and ground. If 24 VAC is not present, but there is 120 VAC at the 120 VAC terminal block, check to see if the in-line fuse connected to the transformer secondary circuit is blown. If the fuse is not blown, check the wiring and connections from the transformer to the low voltage terminal block or ECM control board, and the RED pigtail connection on the ECM control board (if applicable). If the wiring and connections are OK and there is 120 VAC at the transformer primary, replace the transformer. If 24 VAC is present between the RED thermostat pigtail or "R" terminal and ground, continue the troubleshooting process by conducting the following checks.

The following checks should be made before troubleshooting the air handler controls when the blower does not operate or there is a no-heat or no-cooling issue.

1. Check all circuit breakers in the air handler and at the building's main electrical panel. Make sure they are turned to the "ON" position and have not tripped.
2. Check all fuses, especially any supply line fuses that were installed during installation, check the wiring with an OHM meter for a short to ground. If shorted, repair the short, and then replace the fuse.
3. Check any electrical switches that are external to the air handler to make sure they are turned on, especially ON/OFF switches used for servicing the air handler. The service switch is often mistaken for a light switch and is turned off.

4. Check all wiring connections, especially those on the components, to ensure they are securely fastened.

ELECTRIC HEAT MODELS

Check to make sure there is 120VAC between the terminals on the 120VAC power terminal block. If 120V is not present, check to make sure the disconnect switch exterior to the air handler is turned to the ON position and if the circuit breaker in the main electrical panel is in the ON position.

Constant Torque Motor Check

If the blower motor will not run in both the heating and cooling modes and there is 120 VAC at the 120 VAC power terminal block in the control box, check the connections in the blower motor 6-pin plugs (BMMP and BMFP). If those connections are OK, proceed with the following checks.

If the motor is not running, check for 120 VAC between the L and N motor terminals and for 24 VAC at either the RED or BLACK wires connecting to 2 of the motor terminals 1 - 5 when the thermostat is calling for blower operation. Refer to Figure 10 and Table 1 for terminal locations and definitions. If 120 VAC is present between the L and N terminals and 24 VAC is measured between motor terminal C and one of the motor speed tap wires, but the motor is not operating, replace the motor. If 120 VAC is not present between the L and N motor terminals, check the wiring connections to the control board and circuit breaker. If 24 VAC is not present at any of the motor speed tap wires going to the motor terminal block terminals 1 - 5, check the connections to the control board and check to see if the in-line 3A fuse connected to the transformer secondary is blown.

Terminal	Connection
C	Speed Tap Common - 24 VAC Common
L	Supply Voltage - 120VAC
G	Ground Connection
N	Supply Voltage - Neutral
1	Low Speed Tap - 24 VAC Input
2	Medium-Low Speed Tap - 24 VAC Input
3	Medium Speed Tap - 24 VAC Input
4	Medium-High Speed Tap - 24 VAC Input
5	High Speed Tap - 24 VAC Input

Table 1: Constant Torque Motor Terminal Connections

Heating Mode – Electric Heat - Constant Torque Motor

If 24VAC is not present between the “W” terminal on the air handler’s low voltage terminal block and ground when the thermostat is calling for heat, check the wiring and wiring connections from the thermostat “W” terminal to the “W” terminal on the air handler’s low voltage terminal block. If 24 VAC is present on the “W” terminal on the low voltage terminal block, check for 24 VAC on the RED motor speed tap wire connected to the motor terminal block. If 24 VAC is not present on the RED motor speed tap wire, check the wiring and wiring connections between the low voltage terminal block and the blower motor terminal block. If the wiring and connections are OK, replace the motor.

Cooling Mode or Continuous Fan - Constant Torque Motor

If 24 VAC is not present between the “G” and “C” terminals on the air handler’s low voltage terminal block when there is a call for cooling or continuous fan operation, check for 24 VAC between the “R” and “C” terminals on the thermostat. If 24 VAC is not present at the thermostat “R” terminal, check the wiring from the “R” terminal on the air handler’s low voltage terminal block to the thermostat. If there is 24VAC at the thermostat “R” terminal, but not at the “G” terminal on the thermostat when there is a call for cooling or continuous fan operation, replace the thermostat. If there is 24 VAC between the “G” and “C” terminals on the air handler’s low voltage terminal block, check for 24 VAC on the BLACK motor speed tap wire connected to the motor terminal block. If 24 VAC is not present on the BLACK motor speed tap wire, check the wiring and wiring connections between the low voltage terminal block and the blower motor terminal block. If the wiring and connections are OK, replace the motor.

Heating Element Is Not Heating

Check for 208 - 240 VAC between terminals T1 and T2 of the heater contactor(s). If 208 - 240 VAC is present, check the resistance across the heating element terminals. If the heating element resistance is infinity (open circuit), replace the defective heating element.

The heater design is as follows:

- The 5 kW model has one 5 kW heating element.
- The 10 kW model has one heater assembly with two 5 kW heating elements.
- The 15 kW model has one heater assembly with two 5 kW heating elements (top) and one heater assembly with one 5 kW heating element (bottom).
- The 20 kW model has two heater assemblies. Each assembly has two 5 kW heating elements.
- If 208 - 240 VAC is not present between the T1 and T2 terminals (load) of a heater contactor, but there is 208-240 VAC present

⚠ WARNING

To avoid personal injury or property damage, make certain that the motor leads cannot come into contact with non-insulated metal components of the air handler.

⚠ WARNING

For personal safety be sure to turn the electrical power “OFF” at the main electrical panel and at the air handler control box circuit breakers before attempting any service or maintenance operations.

Homeowners should never attempt to perform any maintenance which requires opening the air handler control box cover.

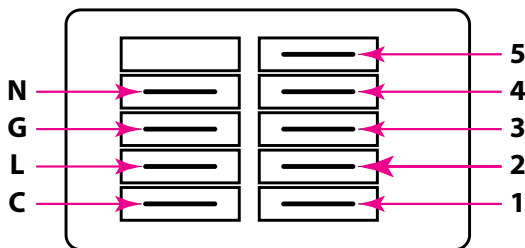

Figure 10: Constant Torque Motor Terminals

between terminals L1 and L2 (line) of that heater contactor, check for an open limit control and replace the open limit control. If 208-240 VAC is not present between the T1 and T2 terminals (load) of a heater contactor, but 208-240 VAC is present between the terminals L1 and L2 (line) of the heater contactor(s) and there is 24 VAC across the coil of that contactor, replace the heater contactor.

Air Handler Model	C.T.
MMVT 24A, 36A	4.79
MMVT 36B, 36B	6.12
MMVT 48C, 60C	7.48
MMVT 60D	7.26

Table 2: 120 Volt Blower Motor Full Load Amperage (FLA) Chart

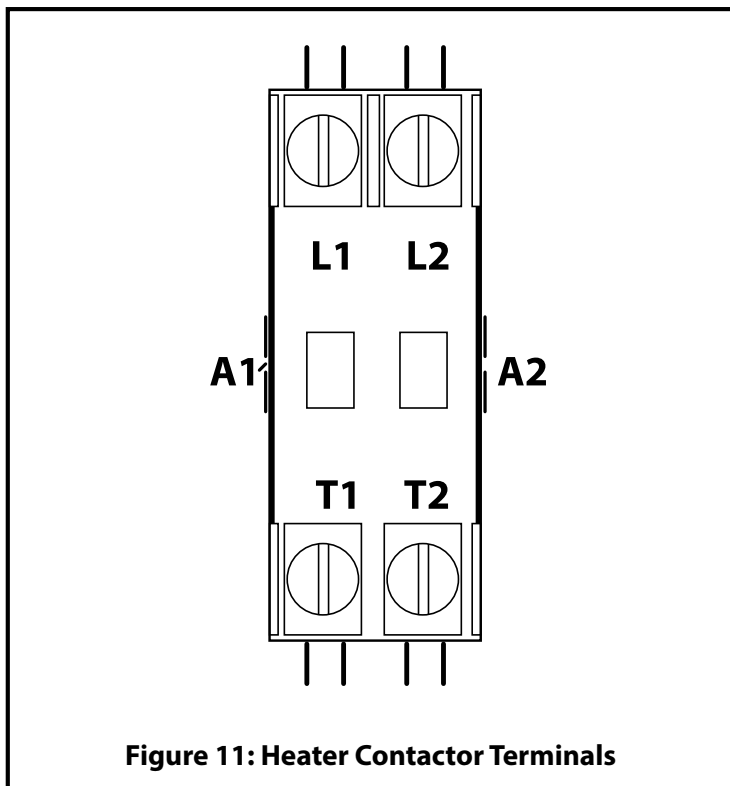

Figure 11: Heater Contactor Terminals

Removing the Blower

1. Turn off the circuit breaker to the air handler at the main electrical panel.
2. Switch the air handler circuit breaker(s) to "OFF" (electric heat models) or the local power disconnect switch to "OFF" (hydronic heat models).
3. Remove the blower / control box access panel.
4. Unplug the wire harnesses from the blower motor.
5. Remove the two screws on the left and right side and the center screw on the bracket in front of the blower mounting plate and slide the blower out.
6. After repairs or checks have been completed, reinstall the blower assembly and secure the assembly to the casing by using the bracket and screws that were removed in step 5.
7. Reinstall the blower / control box access panel.
8. Switch the air handler circuit breaker(s) to "ON" (electric heat models) or the local power disconnect switch to "ON" (hydronic heat models).

9. Turn the circuit breaker to the air handler at the main electrical panel to "ON"
10. Set the thermostat to the desired mode and temperature and
11. observe the air handler startup to ensure it is operating correctly.

Removing the Blower

1. Turn off the circuit breaker to the air handler at the main electrical panel.
2. Switch the air handler circuit breaker(s) to "OFF" (electric heat models) or the local power disconnect switch to "OFF" (no heat models).
3. Remove the blower / control box access panel.
4. Unplug the wire harnesses from the blower motor.
5. Remove the two screws on the left and right side and the center screw on the bracket in front of the blower mounting plate and slide the blower out.
6. After repairs or checks have been completed, reinstall the blower assembly and secure the assembly to the casing by using the bracket and screws that were removed in step 5.
7. Reinstall the blower / control box access panel.
8. Switch the air handler circuit breaker(s) to "ON" (electric heat models) or the local power disconnect switch to "ON" (no heat models).
9. Turn the circuit breaker to the air handler at the main electrical panel to "ON".
10. Set the thermostat to the desired mode and temperature and observe the air handler startup to ensure it is operating correctly.

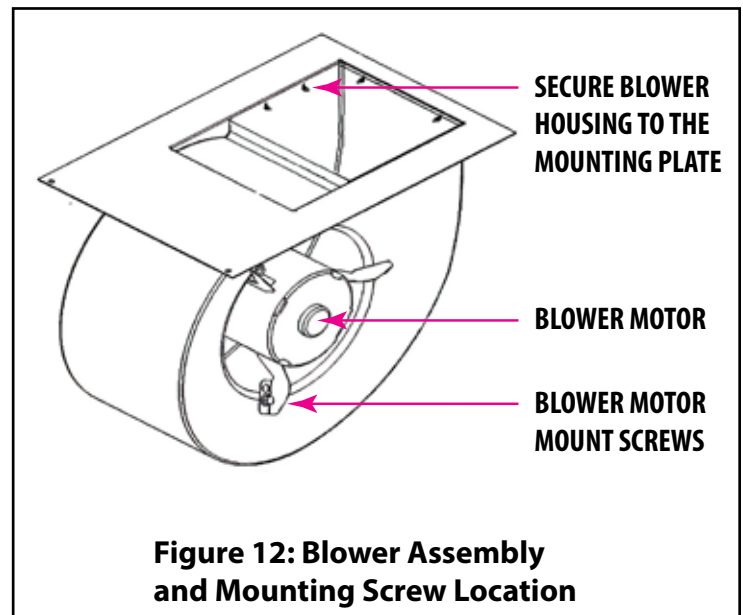

Figure 12: Blower Assembly and Mounting Screw Location

SECTION 6: BLOWER PERFORMANCE

Model Number	Nominal Tons	Motor HP	Volts	Motor Code	Blower Size	Speed Tap	CFM @ 0.10" ESP	CFM @ 0.20" ESP	CFM @ 0.30" ESP	CFM @ 0.40" ESP	CFM @ 0.50" ESP	CFM @ 0.60" ESP
MMVT24A MMVT36A	2-3	1/2	120	VL1 or VL2	10 x 6	5	1436	1382	1312	1269	1202	1202
						4	1128	1092	1047	1021	979	948
						3	1015	982	935	902	864	832
						2	951	902	868	821	788	761
						1	--	627	590	545	506	440
MMVT36B MMVT48B	3-4	3/4	120	VM1 or VM2	10 x 8	5	1727	1667	1577	1504	1410	1361
						4	1718	1629	1530	1472	1399	1311
						3	1575	1530	1503	1465	1376	1274
						2	1285	1248	1222	1179	1147	1110
						1	1051	1012	962	927	885	844
MMVT48C MMVT60C	4-5	3/4	120	VN1 or VN2	12 x 9 T	5	2045	2024	1980	1919	1896	1857
						4	1924	1860	1809	1783	1756	1697
						3	1783	1756	1686	1646	1600	1571
						2	1515	1457	1427	1370	1314	1281
						1	1361	1314	1257	1207	1170	1122
MMVT60D	5	3/4	120	VP1 or VP2	12 x 9 R	5	2244	2211	2143	2094	2037	1985
						4	2084	2028	1972	1923	1858	1832
						3	1883	1816	1758	1714	1647	1612
						2	1697	1637	1578	1534	1463	1411
						1	1570	1493	1441	1402	1329	1285

Table 3: Blower Performance - Constant Torque Motor – With Coil - Without Air Filter

Notes: 1) Minimum CFM for Electric Heat: 5 - 10kW = 650 CFM; 15kW = 1000 CFM; 20 kW = 1400 CFM
 2) CFM and ESP in the table assumes a typical indoor coil has been installed on the air handler.

SECTION 7: ACCESSORIES

MMVT	
Part Number	Description
BAXHK05C	Extra Small Cabinet (A) 5 kW Heater Kit With Circuit Breakers - MMVT
BAXHK10C	Extra Small Cabinet (A) 10 kW Heater Kit With Circuit Breakers - MMVT
BAXHK15C	Extra Small Cabinet (A) 15 kW Heater Kit With Circuit Breakers - MMVT
BBXHK05C	Small (B) Cabinet 5 kW Heater Kit With Circuit Breakers - MMVT
BBXHK10C	Small (B) Cabinet 10 kW Heater Kit With Circuit Breakers - MMVT
BBXHK15C	Small (B) Cabinet 15 kW Heater Kit With Circuit Breakers - MMVT
BBXHK20C	Small (B) Cabinet 20 kW Heater Kit With Circuit Breakers - MMVT
BCXHK05C	Medium (C) Cabinet 5 kW Heater Kit With Circuit Breakers - MMVT
BCXHK10C	Medium (C) Cabinet 10 kW Heater Kit With Circuit Breakers - MMVT
BCXHK15C	Medium (C) Cabinet 15 kW Heater Kit With Circuit Breakers - MMVT
BCXHK20C	Medium (C) Cabinet 20 kW Heater Kit With Circuit Breakers - MMVT
BDXHK05C	Large Cabinet (D) 5 kW Heater Kit With Circuit Breakers - MMVT
BDXHK10C	Large Cabinet (D) 10 kW Heater Kit With Circuit Breakers - MMVT
BDXHK15C	Large Cabinet (D) 15 kW Heater Kit With Circuit Breakers - MMVT
BDXHK20C	Large Cabinet (D) 20 kW Heater Kit With Circuit Breakers - MMVT
86ET0004	Accessory 14 x 25 x 2 Filter Base Kit
86ET0005	Accessory 16 x 25 x 2 Filter Base Kit
86ET0006	Accessory 20 x 25 x 2 Filter Base Kit
86ET0007	Accessory 24 x 25 x 2 Filter Base Kit

Table 4: Accessory List

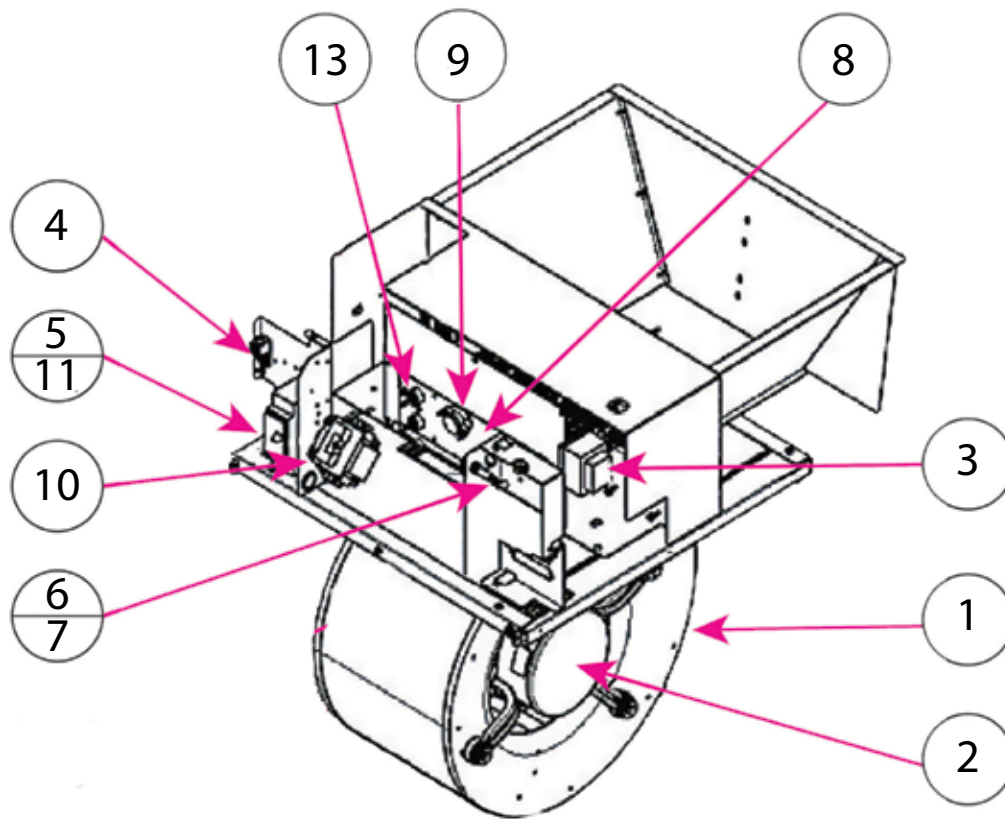

Figure 13: MMVT 24A, 36A Air Handler Replacement Parts Schematic

MMVT 24A, 36A COOL ONLY OR ELECTRIC HEAT			
Item #	Qty	Part #	Description
1	1	R86MH0301	10 x 6 Blower Assembly With 1/2 HP 120 VAC Constant Torque Motor
2	1	R65BV0022 or R65BV0022B	1/2 HP 120 VAC Constant Torque Blower Motor
3	1	R68AA0002	120 VAC to 24V Transformer
4	1	R68DC0001	Ground Lug
5	1	R68DC0018	Power Terminal Block
6	1	R73MH0001	3 Amp Glass Tube Fuse
7	1	R73MHA001	Fuse Holder
5 kW Electric Heat MMVT 24A, 36A			
8	1	R67AB0034	5 kW Electric Heater Element
9	1	R68CA0009	Limit Switch - Opens 165°F - Closes 135°F
10	1	R68AB0019	Double Pole Electric Heater Contactor
11	1	R68BAD013	30 Amp Circuit Breaker
12	1	R68GF0022	Ground Lug - 1/0-14 Wire
13	1	R68CA0011	Non-Resettable Limit Switch - Opens 190°F
10 kW Electric Heat MMVT 24A, 36A			
8	1	R67AB0038	10 kW Electric Heater Element
9	2	R68CA0009	Limit Switch - Opens 165°F - Closes 135°F
10	1	R68AB0019	Double Pole Electric Heater Contactor
11	1	R68BAD018	60 Amp Circuit Breaker
12	1	R68GF0022	Ground Lug - 1/0-14 Wire
13	2	R68CA0011	Non-Resettable Limit Switch - Opens 190°F

Table 5: MSVT 25, 36 Electric Heat Air Handler Replacement Parts List

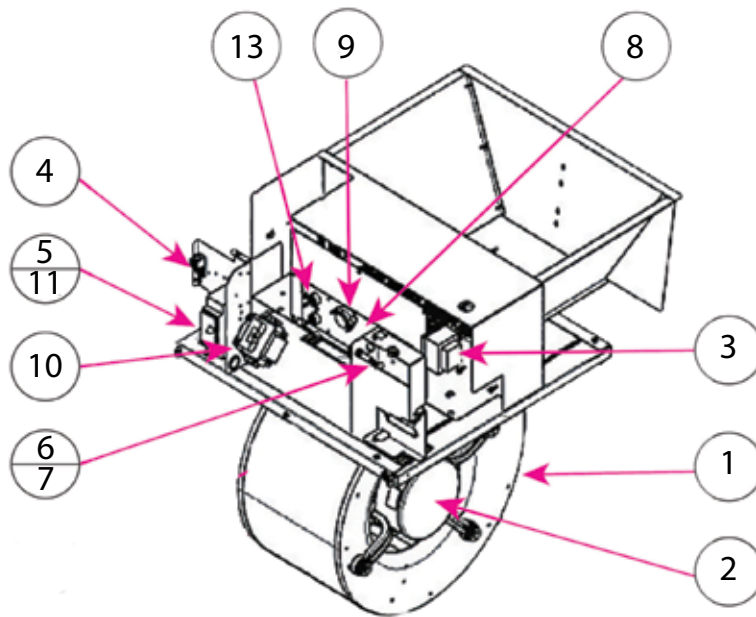

Figure 14: MMVT 36B, 48B Air Handler Replacement Parts Schematic

MMV* 36B, 48B COOL ONLY OR ELECTRIC HEAT			
Item #	Qty	Part #	Description
1	1	R86MH0302	10 x 8 Blower Assembly With 3/4 HP 120 VAC Constant Torque Motor
2	1	R65BV0023 or R65BV0023B	3/4 HP 120 VAC Constant Torque Blower Motor
3	1	R68AA0002	120 VAC to 24 VAC Transformer
4	1	R68DC0001	Ground Lug
5	1	R68DC0018	Power Terminal Block
6	1	R73MH0001	3 Amp Glass Tube Fuse
7	1	R73MHA001	Fuse Holder
5 kW Electric Heat MMVT 36B, 48B			
8	1	R67AB0034	5 kW Electric Heater Element
9	1	R68CA0009	Limit Switch - Opens 165°F - Closes 135°F
10	1	R68AB0019	Double Pole Electric Heater Contactor
11	1	R68BAD013	30 Amp Circuit Breaker
12	1	R68GF0022	Ground Lug - 1/0-14 Wire
13	1	R68CA0011	Non-Resettable Limit Switch - Opens 190°F
10 kW Electric Heat MMVT 36B, 48B			
8	1	R67AB0038	10 kW Electric Heater Element
9	2	R68CA0009	Limit Switch - Opens 165°F - Closes 135°F
10	1	R68AB0019	Double Pole Electric Heater Contactor
11	1	R68BAD018	60 Amp Circuit Breaker
12	1	R68GF0022	Ground Lug - 1/0-14 Wire
13	2	R68CA0011	Non-Resettable Limit Switch - Opens 190°F
15 kW Electric Heat MMVT 36B, 48B			
8	1	R67AB0034	5 kW Electric Heater Element
8	1	R67AB0038	10 kW Electric Heater Element
9	3	R68CA0009	Limit Switch - Opens 165°F - Closes 135°F
10	2	R68AB0019	Double Pole Electric Heater Contactor
11	1	R68BAD018	60 Amp Circuit Breaker
12	2	R68GF0022	Ground Lug - 1/0-14 Wire
13	3	R68CA0011	Non-Resettable Limit Switch - Opens 190°F

Table 6: MMVT 36B, 48B Air Handler Replacement Parts List

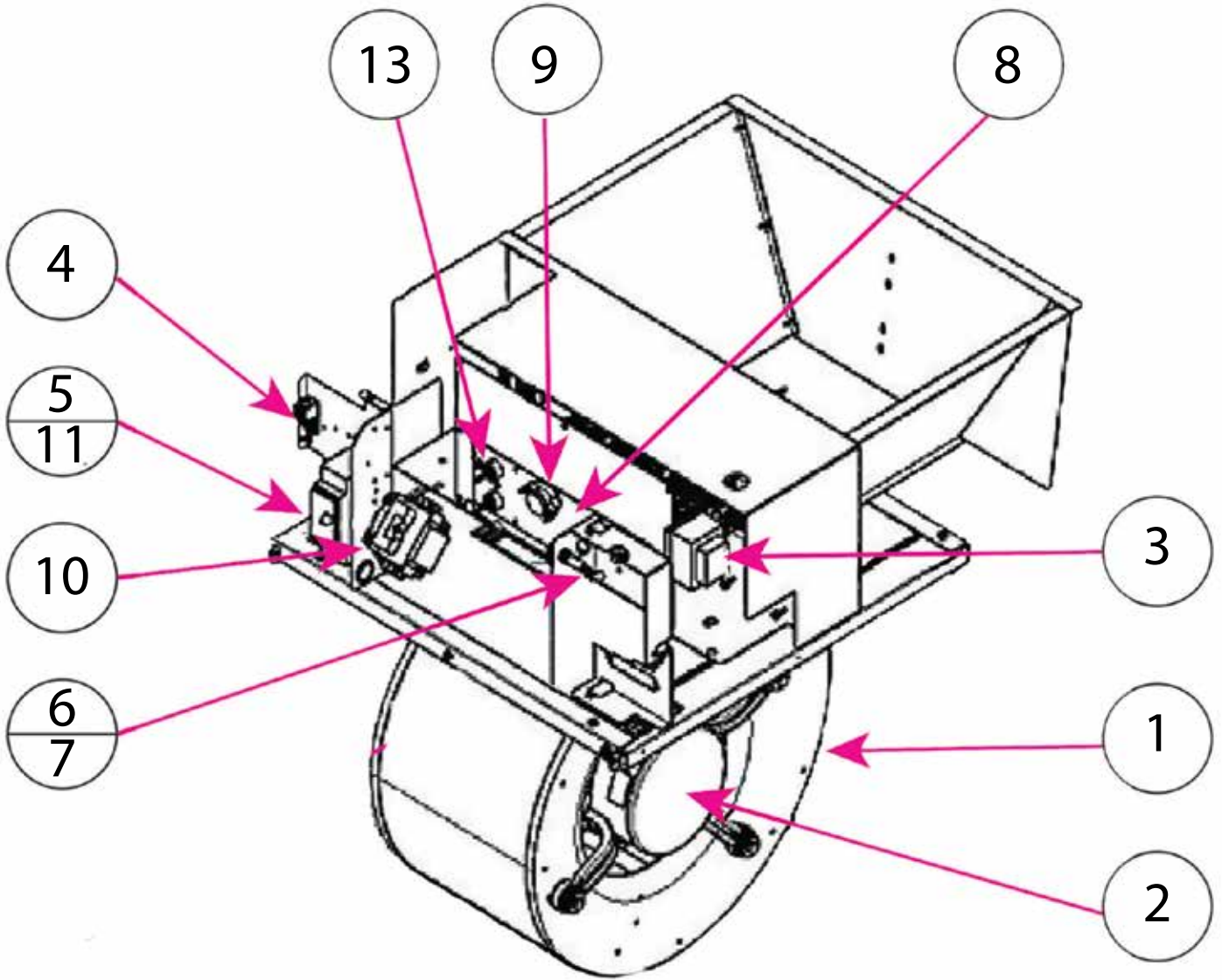

Figure 13: MMVT 24A, 36A Air Handler Replacement Parts Schematic

MMVT 48C, 60C, 60D COOL ONLY OR ELECTRIC HEAT			
Item #	Qty	Part #	Description
1	1	R86MH0303	12 x 9 T Blower Assembly With 3/4 HP 120 VAC Constant Torque Motor – MMVT48C, 60C
1	1	R86MH0304	12 x 9 R Blower Assembly With 3/4 hp 120 VAC Constant Torque Motor – MMVT 60D
2	1	R65BV0023 or R65BV0023B	3/4 HP 120 VAC Constant Torque Blower Motor
3	1	R68AA0002	120 VAC to 24 VAC Transformer
4	1	R68DC0001	Ground Lug
5	1	R68DC0018	Power Terminal Block
6	1	R73MH0001	3 Amp Glass Tube Fuse
7	1	R73MHA001	Fuse Holder
5 kW Electric Heat MMVT 48C, 60C, 60D			
8	1	R67AB0034	5 kW Electric Heater Element
9	1	R68CA0009	Limit Switch - Opens 165°F - Closes 135°F
10	1	R68AB0019	Double Pole Electric Heater Contactor
11	1	R68BAD013	30 Amp Circuit Breaker
12	1	R68GF0022	Ground Lug - 1/0-14 Wire
13	1	R68CA0011	Non-Resettable Limit Switch - Opens 190°F
10 kW Electric Heat MMVT 48C, 60C, 60D			
8	1	R67AB0038	10 kW Electric Heater Element
9	2	R68CA0009	Limit Switch - Opens 165°F - Closes 135°F
10	1	R68AB0019	Double Pole Electric Heater Contactor
11	1	R68BAD018	60 Amp Circuit Breaker
12	1	R68GF0022	Ground Lug - 1/0-14 Wire
13	2	R68CA0011	Non-Resettable Limit Switch - Opens 190°F
15 kW Electric Heat MMVT 48C, 60C, 60D			
8	1	R67AB0034	5 kW Electric Heater Element
8	1	R67AB0038	10kW Electric Heater Element
9	3	R68CA0009	Limit Switch - Opens 165°F - Closes 135°F
10	2	R68AB0019	Double Pole Electric Heater Contactor
11	1	R68BAD018	60 Amp Circuit Breaker
12	2	R68GF0022	Ground Lug - 1/0-14 Wire
13	3	R68CA0011	Non-Resettable Limit Switch - Opens 190°F
20 kW Electric Heat MMVT 48C, 60C, 60D			
8	2	R67AB0038	10 kW Electric Heater Element
9	4	R68CA0009	Limit Switch - Opens 165°F - Closes 135°F
10	2	R68AB0019	Double Pole Electric Heater Contactor
11	1	R68BAD018	60 Amp Circuit Breaker
12	2	R68GF0022	Ground Lug - 1/0-14 Wire
13	4	R68CA0011	Non-Resettable Limit Switch - Opens 190°F

Table 6: MMVT 36B, 48B Air Handler Replacement Parts List